

Dwg.		Resp.Off.		Title Installation, service and maintenance instructions for low voltage air circuit-breakers	Language
App.		Take-over Off.			en
Model	L2234			Apparatus Emax	Scale
ABB		ABB SACE		Doc. N° 1SDH000460R0002	

Index		11.2.1 Abbreviations page 30	
		11.2.2 Notes « 30	
1. Description page 6		12. SACE PR121/P Release - Identification « 31	
1.1 General characteristics « 6		12.1 Standard « 31	
1.2 External front view of the circuit-breaker « 6		12.2 Specifications « 31	
1.3.1 Circuit-breaker rating plate « 6		12.2.1 General « 31	
1.3.2 Disconnecter rating plate « 6		12.2.2 Electrical characteristics « 31	
1.4 Moving part construction characteristics « 6		12.2.2.1 Self-supply « 31	
1.5 Fixed part construction characteristics « 7		12.2.2.2 Auxiliary power supply « 31	
2. Checking on receipt « 7		12.2.3 Environmental characteristics « 32	
3. Storage, lifting and weights « 7		12.2.4 Communication bus « 32	
4. Installation « 8		12.2.5 Protection functions « 32	
4.1 Installation room « 8		12.2.5.1 Calculating the RMS and peak « 32	
4.2 Installation of the fixed circuit-breaker « 8		12.2.5.2 Watchdog « 32	
4.3 Installation of the fixed part of the withdrawable circuit-breaker « 8		12.2.6 Description of the protection functions « 32	
4.3.1 Preparation of the fixed part « 8		12.2.6.1 Protection "L" « 32	
4.3.2 Installation of the fixed part « 9		12.2.6.2 Protection "S" « 32	
4.3.3 Installation of the fixed part on board a ship « 9		12.2.6.3 Protection "I" « 33	
4.4 Installation of the flange on the compartment door « 10		12.2.6.4 Protection "G" « 33	
5. Electrical connections « 10		12.2.6.5 Protection against instantaneous short-circuits "Iinst" .. « 33	
5.1 Connections to the power circuit « 10		12.2.7 Summary table of protections « 33	
5.1.1 Shapes of the terminals « 10		12.2.8 Measurements « 33	
5.1.2 Examples of positioning the connection busbars according to the types of terminal « 11		12.2.9 Trip curves « 34	
5.1.3 Assembly procedure for the connection busbars « 12		12.2.9.1 Trip curves for functions L-I « 34	
5.2 Earthing « 12		12.2.9.2 Trip curves for functions L-S($t=k/l^2$)-I « 34	
5.3 Wiring the circuit-breaker auxiliary circuits « 12		12.2.9.3 Trip curves for functions L-S($t=k$)-I « 35	
5.3.1 Interfacing elements for fixed circuit-breakers « 12		12.2.9.4 Trip curves for function G « 35	
5.3.2 Withdrawable circuit-breaker « 13		12.3 Other functions « 36	
5.4 Conversion of the auxiliary contacts or of the signalling contacts (disconnected - test isolated - connected) from normally closed (opening) to normally open (closing) or vice versa « 14		12.3.1 Indication of the cause of the trip and trip test button « 36	
6. Putting into service « 15		12.4 Putting into service « 36	
6.1 General procedures « 15		12.4.1 Connections « 36	
7. Instructions for use « 16		12.4.2 CS and TC connection check « 36	
7.1 Operating and signalling parts « 16		12.4.3 Current sensor connection for external neutral « 36	
7.2 Circuit-breaker closing and opening procedures « 17		12.5 User interface « 36	
7.3 Racking-in/out operation « 18		12.5.1 Trip Test « 37	
8. Maintenance « 19		12.5.2 Initial settings « 37	
8.1 Warning « 19		12.5.3 Changing protection functions « 37	
8.2 Maintenance program « 20		12.5.3.1 Example of settings « 37	
8.3 Maintenance operations « 20		12.5.4 PR121/P default settings « 38	
8.3.1 Preliminary operations « 20		12.6 Operating instructions / Operation in service « 38	
8.3.2 General inspection of the circuit-breaker « 21		12.6.1 Adjusting the neutral « 38	
8.3.3 Checking contact wear « 21		12.6.2 Table of neutral adjustments « 38	
8.3.4 Operating mechanism maintenance « 22		12.6.3 Replacing an electronic release « 38	
9. Measures to be taken for any operating anomalies « 23		12.7 Definition of the alarms and signals for the PR121/P unit « 39	
10. Accessories « 24		12.7.1 Optical signals « 39	
10.1 Electrical accessories « 24		12.7.2 Troubleshooting « 39	
10.2 Mechanical locks « 27		12.7.3 In the case of a fault « 40	
10.3 Spare parts and retrofitting « 28		12.8 Accessories « 40	
11. Protection releases - General notes « 29		12.8.1 ABB SACE PR010/T test and configuration unit « 40	
11.1 Safety notes « 30		12.8.2 BT030 communication unit « 40	
11.1.1 Notes for dielectric stiffness tests « 30		12.8.3 PR021/K and HMI030 units « 40	
11.2 Abbreviations and notes « 30		12.9.4 PR030/B power supply unit « 40	
		13. SACE PR122/P Release - Identification « 41	
		13.1 Standard « 41	
		13.2 Specifications « 41	
		13.2.1 General « 41	
		13.2.2 Electrical characteristics « 42	
		13.2.2.1 Self-supply « 42	
		13.2.2.2 Auxiliary power supply « 42	
		13.2.2.3 Powered by PR120/V module « 42	
		13.2.3 Environmental characteristics « 42	
		13.2.4 Description of inputs/outputs « 42	
		13.2.4.1 Binary opto-insulated inputs « 42	
		13.2.4.2 Binary opto-insulated outputs « 42	

Model	L2234			Apparatus	Emax	Scale
				Doc. No.	1SDH000460R0002	Page No. 1/155

13.2.5	Communication bus	page	42	13.4.3.1	Modification of basic configuration	page	61
13.2.6	Protection functions	«	42	13.4.4	Default settings	«	62
13.2.6.1	Calculating the RMS and peak	«	43	13.5	Operating instructions / Operation in service	«	63
13.2.6.2	Mains frequency	«	43	13.5.1	Menu	«	63
13.2.6.3	Harmonic distortion	«	43	13.5.2	Protections Menu	«	64
13.2.6.4	Circuit-breaker state	«	43	13.5.2.1	Protections Menu table	«	64
13.2.7	Measurement functions	«	43	13.5.3	Measurements Menu	«	67
13.2.8	Watchdog	«	43	13.5.3.1	Measurements Menu table	«	67
13.2.9	Description of the protection functions	«	44	13.5.4	Settings Menu	«	67
13.2.9.1	Protection "L"	«	44	13.5.4.1	Settings Menu table	«	67
13.2.9.1.1	Thermal memory "L"	«	44	13.5.4.2	Neutral adjustments	«	68
13.2.9.2	Protection "S"	«	44	13.5.4.2.1	Neutral adjustments table	«	68
13.2.9.2.1	Thermal memory "S"	«	44	13.5.4.3	Mains frequency settings	«	68
13.2.9.2.2	Start-up threshold "S"	«	44	13.5.4.4	Modules	«	68
13.2.9.2.3	Zone selectivity "S"	«	45	13.5.4.4.1	PR120/V MEASURING module	«	68
13.2.9.3	Protection "I"	«	45	13.5.4.4.2	PR120/D-M - COM module	«	69
13.2.9.3.1	Start-up threshold "I"	«	45	13.5.4.4.3	PR120/K - SIGNALLING module	«	69
13.2.9.4	Protection "G"	«	45	13.5.4.4.4	PR120/D - WL-COM module	«	69
13.2.9.4.1	Start-up threshold "G"	«	46	13.5.4.4.5	Settings for the Local Bus unit	«	69
13.2.9.4.2	Zone selectivity "G"	«	46	13.5.5	Test Menu	«	69
13.2.9.5	Protection against phase unbalance "U"	«	46	13.5.5.1	Test Menu table	«	69
13.2.9.6	Protection against overtemperature inside the relay "OT"	«	46	13.5.6	Information Menu	«	70
13.2.9.7	Load control function	«	47	13.5.6.1	Information on the trip and opening data	«	70
13.2.9.8	Voltage protections "UV", "OV", "RV"	«	47	13.6	Definition of alarms and signals in the PR122/P unit	«	70
13.2.9.8.1	Protection "UV"	«	47	13.6.1	Optical signals	«	70
13.2.9.8.2	Protection "OV"	«	47	13.6.2	Electrical signals	«	70
13.2.9.8.3	Protection "RV"	«	47	13.6.3	Table of error and warning messages	«	71
13.2.9.9	Reverse active power protection "RP"	«	47	13.6.4	Error messages displayed in pop-up windows	«	72
13.2.9.10	Frequency protections "UF", "OF"	«	47	13.7	Troubleshooting PR122/P unit	«	73
13.2.9.11	Summary table of the protection function setting for the PR122/P	«	48	13.7.1	In the case of a fault	«	73
13.2.9.11.1	Summary of the additional protection functions for the PR122/P with the optional PR120/V module	«	49	13.8	Accessories	«	74
13.2.9.11.2	Table of measurements	«	49	13.8.1	ABB SACE PR010/T test and configuration unit	«	74
13.2.10	Trip curves	«	50	13.8.2	ABB SACE PR030/B power supply unit	«	74
13.2.10.1	Trip curves for functions L-I	«	50	13.8.3	BT030 wireless communication unit	«	74
13.2.10.2	Trip curves for functions L-S($t=k/I^2$)-I	«	50	14.	SACE PR123/P Release Identification	«	75
13.2.10.3	Trip curves for functions L-S($t=k$)-I	«	51	14.1	Standard	«	75
13.2.10.4	Trip curves for function L in accordance with IEC-60255-3 (type A)	«	51	14.2	Specifications	«	75
13.2.10.5	Trip curves for function L in accordance with IEC-60255-3 (type B)	«	52	14.2.1	General	«	75
13.2.10.6	Trip curves for function L in accordance with IEC-60255-3 (type C)	«	52	14.2.2	Electrical characteristics	«	76
13.2.10.7	Trip curves for function G	«	53	14.2.2.1	Self-supply	«	76
13.2.10.8	Trip curves for function U	«	53	14.2.2.2	Auxiliary supply	«	76
13.2.10.9	Trip curves for function UV	«	54	14.2.2.3	Powered by the PR120/V module	«	76
13.2.10.10	Trip curves for function OV	«	54	14.2.3	Environmental characteristics	«	76
13.2.10.11	Trip curves for function RV	«	55	14.2.4	Description of inputs/outputs	«	76
13.2.10.12	Trip curves for function RP	«	55	14.2.4.1	Binary opto-insulated inputs	«	76
13.3	Putting into service	«	56	14.2.4.2	Binary opto-insulated outputs	«	76
13.3.1	Connections	«	56	14.2.5	Communication bus	«	76
13.3.1.1	Current sensor connection for external neutral	«	56	14.2.6	Protection functions	«	76
13.3.2	VT connections	«	56	14.2.6.1	RMS and peak calculation	«	77
13.3.3	CS and TC connection test	«	56	14.2.6.2	Mains frequency	«	77
13.3.4	Test	«	56	14.2.6.3	Harmonic distortion	«	77
13.3.5	Initial settings	«	57	14.2.6.4	Circuit-breaker state	«	77
13.3.6	Password management	«	57	14.2.7	Measurement functions	«	77
13.3.7	Changing the electronic release	«	57	14.2.8	Watchdog	«	77
13.3.7.1	Installation	«	57	14.2.9	Description of the protection functions	«	78
13.3.7.2	Uninstalling	«	57	14.2.9.1	Protection "L"	«	78
13.4	User interface	«	58	14.2.9.1.1	Thermal memory "L"	«	78
13.4.1	Use of pushbuttons	«	58	14.2.9.2	Protection "S"	«	78
13.4.2	Read and Edit modes	«	58	14.2.9.2.1	Thermal memory "S"	«	78
13.4.3	Changing parameters	«	59	14.2.9.2.2	Start-up threshold "S"	«	78
				14.2.9.2.3	Zone selectivity "S"	«	79
				14.2.9.3	Double S	«	79
				14.2.9.4	Directional Protection "D"	«	79
				14.2.9.4.1	Start-up threshold "D"	«	80
				14.2.9.4.2	"D" (directional) zone selectivity	«	80

Model	L2234			Apparatus	Emax	Scale
				Doc.No.	1SDH000460R0002	Page No. 2/155

14.2.9.5	Protection "I"	page 81	14.5.4.4.3	PR120/K module	page 105
14.2.9.5.1	Start-up threshold "I"	< 81	14.5.4.4.4	PR120/D - WL-COM module	< 105
14.2.9.6	Protection "G"	< 81	14.5.4.4.5	Settings for the Local Bus unit	< 105
14.2.9.6.1	Start-up threshold "G"	< 82	14.5.5	Test Menu	< 105
14.2.9.6.2	Zone selectivity "G"	< 82	14.5.5.1	Test Menu table	< 106
14.2.9.7	Protection against phase unbalance "U"	< 82	14.5.6	Informations Menu	< 106
14.2.9.8	Protection against overtemperature inside the relay "OT"	< 82	14.5.6.1	Information on the trip and opening data	< 106
14.2.9.9	Load control function	< 83	14.6	Definitions of alarms and signals in the PR123/P unit	< 107
14.2.9.10	Voltage protections "UV", "OV", "RV"	< 83	14.6.1	Optical signals	< 107
14.2.9.10.1	Protection "UV"	< 83	14.6.2	Electrical signals	< 107
14.2.9.10.2	Protection "OV"	< 83	14.6.3	Table of error and warning messages	< 107
14.2.9.10.3	Protection "RV"	< 83	14.6.4	Error messages displayed in pop-up windows	< 108
14.2.9.11	Protection against reverse active power "RP"	< 83	14.7	Troubleshooting PR123/P unit	< 109
14.2.9.12	Frequency protections "UF", "OF"	< 83	14.7.1	In the case of a fault	< 109
14.2.9.13	Double protections setting	< 83	14.8	Accessories	< 110
14.2.9.14	Summary table of the protection function settings for the PR123/P	< 84	14.8.1	ABB SACE PR010/T test and configuration unit	< 110
14.2.9.15	Table of measurements	< 85	14.8.2	ABB SACE PR030/B power supply unit	< 110
14.2.10	Trip curves	< 86	14.8.3	BT030 wireless communication unit	< 110
14.2.10.1	Trip curves for functions L-S($t=k/I^2$)-I	< 86	15	Modules	< 111
14.2.10.2	Trip curves for functions L-S($t=k$)-I	< 86	15.1	PR120/V - MEASURING Module	< 111
14.2.10.3	Trip curves for function G	< 87	15.1.1	General characteristics	< 111
14.2.10.4	Trip curves for function L in accordance with IEC 60255-3 (type A)	< 87	15.1.2	Front view	< 111
14.2.10.5	Trip curves for function L in accordance with IEC 60255-3 (type B)	< 88	15.1.3	Releases complete with the module	< 111
14.2.10.6	Trip curves for function L in accordance with IEC 60255-3 (type C)	< 88	15.1.4	Powering the PR122/P and PR123/P units via the PR120/V module	< 111
14.2.10.7	Trip curves for function D	< 89	15.1.5	Operating instructions / Operation in service	< 112
14.2.10.8	Trip curves for function U	< 89	15.1.5.1	Using the Measurement submenus with the PR120/V	< 112
14.2.10.9	Trip curves for function UV	< 90	15.1.5.2	Table of submenus for the PR120/V module	< 114
14.2.10.10	Trip curves for function OV	< 90	15.1.5.3	Measurements Menu table	< 114
14.2.10.11	Trip curves for function RV	< 91	15.1.5.4	Measurements Menu	< 115
14.2.10.12	Trip curves for function RP	< 91	15.1.5.4.1	Historicals	< 115
14.3	Putting into service	< 92	15.1.5.4.2	Openings	< 115
14.3.1	Connections	< 92	15.1.5.4.3	Events	< 115
14.3.1.1	Current sensor connection for external neutral	< 92	15.1.5.4.4	Measurements	< 115
14.3.2	VT connections	< 92	15.1.5.4.5	Power factor	< 115
14.3.3	CS and TC connection test	< 92	15.1.5.4.6	Energy	< 116
14.3.4	Test	< 92	15.1.5.4.7	Peak factor	< 116
14.3.5	Initial settings	< 93	15.1.5.4.8	Mains frequency	< 116
14.3.6	Password management	< 93	15.1.5.4.9	Contact wear	< 116
14.3.7	Changing the electronic release	< 93	15.1.5.4.10	Waveforms	< 116
14.3.7.1	Installation	< 93	15.1.6	Data Logger	< 116
14.3.7.2	Uninstalling	< 93	15.1.7	Electrical characteristics of the transformers	< 117
14.4	User interface	< 94	15.2	PR120/D-M - COM COMMUNICATION Module	< 118
14.4.1	Use of pushbuttons Utilizzo dei pulsanti	< 94	15.2.1	General characteristics	< 118
14.4.2	Read and Edit modes	< 94	15.2.2	Front view	< 118
14.4.3	Changing parameters	< 95	15.2.3	Releases complete with the module	< 118
14.4.3.1	Modification of basic configuration	< 97	15.2.4	Power supply	< 118
14.4.4	Default settings	< 98	15.2.5	Connection	< 118
14.5	Operating instructions / Operation in service	< 99	15.2.6	Communication functions available	< 118
14.5.1	Menu	< 99	15.2.7	PR120/D-M - COM module menu	< 118
14.5.2	Protections Menu	< 100	15.3	PR120/K - SIGNALLING Module	< 119
14.5.2.1	Protections Menu table	< 100	15.3.1	General characteristics	< 119
14.5.3	Measurements Menu	< 103	15.3.2	Front view	< 119
14.5.3.1	Measurements Menu table	< 103	15.3.3	Releases complete with the module	< 119
14.5.4	Settings Menu	< 103	15.3.4	Characteristics of the digital input	< 119
14.5.4.1	Settings Menu table	< 103	15.3.5	Characteristics of the signalling contacts	< 119
14.5.4.2	Adjusting the neutral	< 104	15.3.6	Power supply	< 120
14.5.4.2.1	Neutral adjustments table	< 104	15.3.7	PR120/K module menu	< 120
14.5.4.3	Mains frequency settings	< 104	15.3.8	Programming contacts K51/p1, K51/p2, K51/p3 and K51/p4	< 121
14.5.4.4	Modules	< 105	15.3.9	Configurable input	< 121
14.5.4.4.1	PR120/V module	< 105	15.3.9.1	Input configuration settings	< 121
14.5.4.4.2	PR120/D-M - COM module	< 105	15.3.9.2	Input function settings (ACTION)	< 121
			15.3.9.3	Setting the input enabling delay	< 121
			15.3.10	PR120/K module menu layout	< 122

Model	L2234			Apparatus	Emax	Scale
				Doc. No.	1SDH000460R0002	Page No. 3/155

15.4	PR120/D-WL - COM module	page 122
15.4.1	General characteristics	< 123
15.4.2	Front view	< 123
15.4.3	Releases complete with the module	< 123
15.4.4	Power supply	< 123
15.4.5	Connection	< 123
16	Appendices	< 124
16.1	PR021/K outside signalling unit	< 124
16.1.1	General information	< 124
16.1.2	Power supply	< 124
16.1.3	General characteristics of the signalling relays	< 124
16.1.4	Relay functions	< 124
16.1.5	PR021/K signalling unit menu	< 124
16.1.5.1	PR021/K unit menu table	< 125
16.1.5.2	Important note	< 125
16.2	SD-Pocket	< 126
16.3	SD-Testbus	< 126
16.4	Data Logger (recorder)	< 127
16.4.1	General characteristics	< 127
16.4.2	Description of the Data Logger menu	< 127
16.4.2.1	Data Logger enabled	< 127
16.4.2.2	Setting the sampling frequency	< 127
16.4.2.3	Setting the standard (trigger) stop sources	< 127
16.4.2.4	Setting and viewing customized trigger points	< 128
16.4.2.5	Setting the stopping delay	< 128
16.4.2.6	Restart/Stop Data Logger	< 128
16.4.3	Recording time windows	< 128
16.4.4	Description of the information given by the Data Logger system	< 129
16.4.4.1	Combination of devices for reading/setting data from the Data Logger system	< 129
16.4.4.2	Access to the saved data from the system	< 129
16.4.4.3	Information from the system on the configuration and status of the Data Logger	< 130
16.4.5	Data Logger commands from the systems	< 130
16.5	Table showing lists of events	< 131
16.5.1	"Standard" events for PR120/K and for PR121/K selectable from the relay	< 131
16.5.2	"Standard" events for the Data Logger function	< 131
16.5.3	Examples of "Custom" events for the Data Logger function for PR120/K and PR121/K	< 131
16.5.4	Combining the devices needed to customize settings	< 131
17.	Overall dimensions	< 132
18.	Circuit diagrams	< 146

Model	L2234			Apparatus	Emax	Scale
				Doc.No.	1SDH000460R0002	Page No. 4/155

Model	L2234			Apparatus Emax	Scale
				Doc. No. 1SDH000460R0002	Page No. 5/155

1. Description

1.1 General characteristics

The SACE Emax series of circuit-breakers and disconnectors consists of a steel sheet structure which houses the operating mechanism, the poles and the auxiliary parts. Each pole, insulated from the others, contains the circuit-breaking parts and the current transformer of the corresponding phase.

The structure of the poles differs according to whether the circuit-breaker is selective or current-limiting.

The fixed version circuit-breaker has its own terminals for connection to the power circuit; in the withdrawable version the circuit-breaker comprises the moving part of the apparatus, which is completed with a fixed part fitted with the terminals for connection to the power circuit of the installation. The moving part and the fixed part coupled by means of special contacts installed in the fixed part.

1.2 External front view of the circuit-breaker

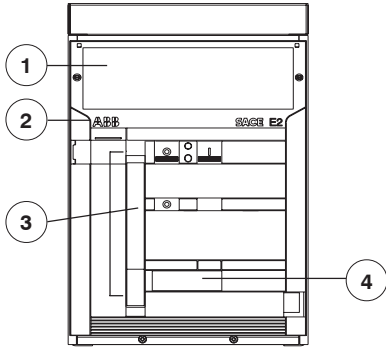

Fixed circuit-breaker

- 1 PR121, PR122 or PR123 electronic microprocessor-based release
- 2 Trade mark
- 3 Operating and control parts of the operating mechanism and release tripped signals
- 4 Rating plate

Fig. 2a

1.3.1 Circuit-breaker rating plate

SACE E2B 16	$I_n=1600A$	$U_e=690V$	$I_{cw}=42kAx1s$	
U_e (V)	230	415	440	525 690
I_{cu} (kA)	42	42	42	42 42
I_{cs} (kA)	42	42	42	42 42
cat.B	~ 50-60Hz			IEC 60947-2 made in Italy by ABB-SACE

1.3.2 Disconnector rating plate

SACE E2B/MS 16	$I_n=1600A$	$U_e=690V$	$I_{cw}=42kAx1s$	
U_e (V)	400/415	690	250	500
I_e (kA)	1600	1600	1600	1600
Cat.	AC - 23A	DC - 23A		
	~ 50-60Hz	1P --- 2P	IEC 60947-3 made in Italy by ABB-SACE	

Fig. 2b

1.4 Moving part construction characteristics

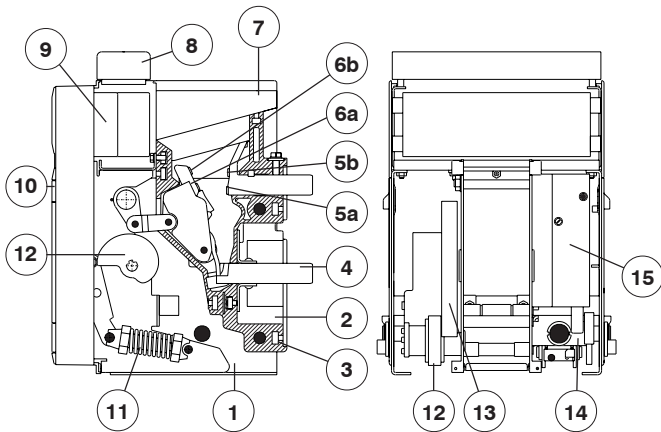

Selective circuit-breaker

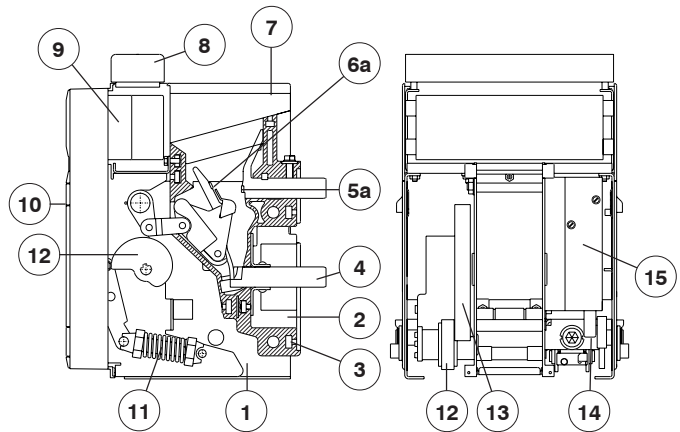

Current-limiting circuit-breaker

- 1 Supporting structure made of steel sheet
- 2 Current transformer for protection release
- 3 Terminal supporting molded case /insulating box
- 4 Horizontal rear terminals
- 5a Main fixed contact plates
- 5b Fixed arcing contact plates
- 6a Main moving contact plates
- 6b Moving arcing contact plates
- 7 Arcing chamber

- 8 Terminal box for the fixed version-Sliding contacts for the withdrawable version
- 9 Protection release
- 10 Circuit-breaker closing and opening mechanism
- 11 Closing springs
- 12 Spring loading geared motor (on request)
- 13 Lever for manually loading the closing springs
- 14 Racking-out device (only for withdrawable circuit breakers)
- 15 Service releases (shunt closing release, shunt opening release, under-voltage release)(on request)

Fig. 3

Model	L2234		Apparatus	Emax	Scale
			Doc.No.	1SDH000460R002	Page No. 6/155

1.5 Fixed part construction characteristics

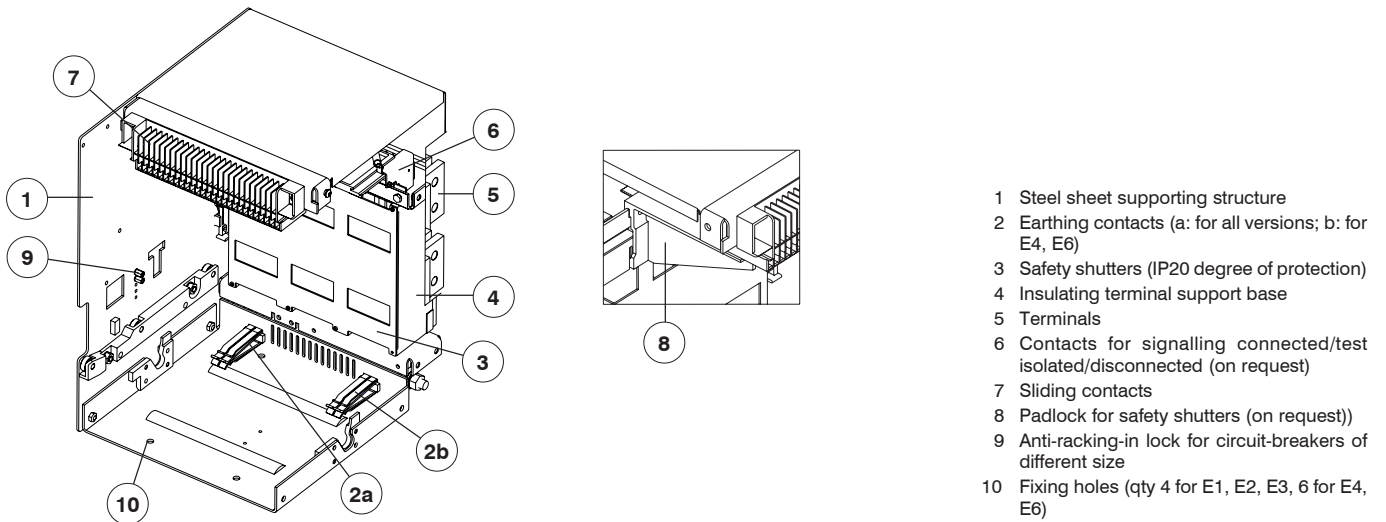

Fig. 4

2. Checking on receipt

Examine the state of the material received and its consistency with the content of the order. Should any damage or errors be found on unpacking, which must be carried out carefully, make the relative notification within and not over 5 days from the receipt of the material. The notification must indicate the number of the shipping note.

3. Storage, lifting and weights

The circuit-breaker, protected by an external wooden crate, is fixed by means of screws to the transport pallet or to the bottom of the packing case. If the circuit-breaker has to remain in the warehouse even for a short time before being put into service, after checking it on receipt, it must be put back in its container and covered with a waterproof sheet.

Caution

- Use a dry, dust-free room free of aggressive chemical agents as a storage room
- Position the circuit-breaker and any fixed part on a horizontal surface, not in direct contact with the floor, but on a suitable support surface (Fig. 5)
- The maximum number of stackable circuit-breakers is indicated in figure 6.
- Keep the circuit-breaker in the open position and with the closing springs unloaded to avoid unnecessary stresses and the risk of accidents to the personnel.

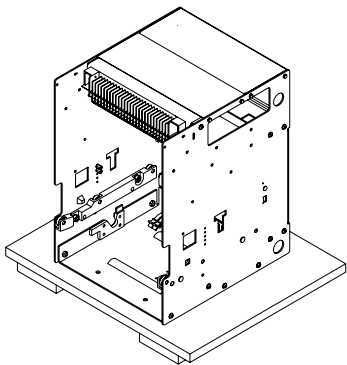

Fig. 5

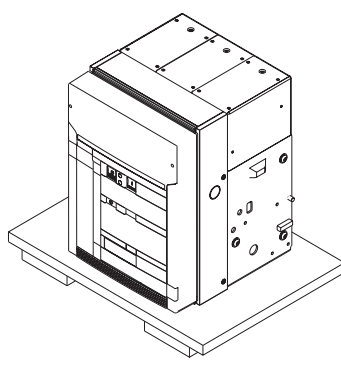
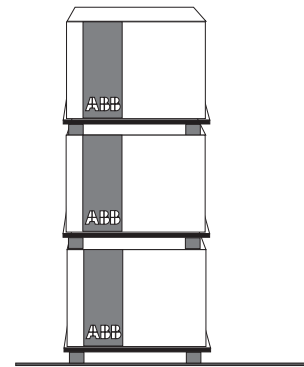

Fig. 6



Model	L2234		Apparatus	Emax	Scale
			Doc. No.	1SDH000460R0002	Page No. 7/155

With regard to lifting, follow the instructions: the circuit-breakers must be placed on a sturdy supporting surface and lifted, preferably, by means of a special fork-lift truck. However, the use of ropes is allowed. In this case, the lifting ropes must be hooked up as shown in the figures (the lifting plates are always supplied with the circuit-breaker).

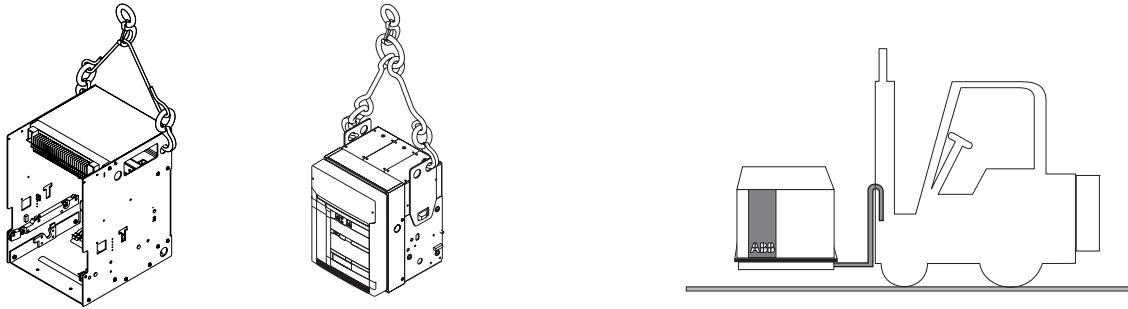

Fig. 7

Table of the circuit-breaker weights (Kg.)

Selective circuit-breaker	Fixed version		Withdrawable version	
	3 poles	4 poles	3 poles	4 poles
E1	45	54	70	82
E2	50	61	78	93
E3	66	80	104	125
E4	97	117	147	165
E4/f		120		170
E6	140	160	210	240
E6/f		165		250

Current-limiting circuit-breaker	Fixed version		Withdrawable version	
	3 poles	4 poles	3 poles	4 poles
E2L	52	63	80	95
E3L	72	83	110	127

Notes

The weights indicated in the table are intended for circuit-breakers complete with PR121, PR122 or PR123 releases and relative current sensors, excluding the accessories. The withdrawable version includes the moving part in the same conditions as above, and the fixed part with horizontal rear terminals.

4. Installation

4.1 Installation room

Install the circuit-breaker in a dry, dust-free, non-corrosive room, and in such a way that it is not subject to shocks or vibrations. Where this is not possible, install it inside a switchboard with a suitable degree of protection.

For the preparation of the installation room, please refer to the "Overall dimensions" paragraph, which gives information on the following points:

- minimum installation volumes of the circuit-breakers and derived versions
- distances to be respected for circuit-breakers in compartments
- overall dimensions of the circuit-breakers
- fixing drillings
- compartment door drillings

The installation, commissioning and any ordinary and extraordinary maintenance have to be done by skilled personnel, with a detailed knowledge of the apparatus.

4.2 Installation of the fixed circuit-breaker

Fix the circuit-breaker to a horizontal surface using the screws (M10 x 12 min.).

4.3 Installation of the fixed part of the withdrawable circuit-breaker

4.3.1 Preparation of the fixed part

Assembly of the anti-racking-in lock

Before installing the fixed part, it is necessary to check the presence of the anti-racking-in lock for circuit-breakers with different electrical characteristics from those of the fixed part. If the anti-racking-in lock has been supplied separately, proceed to assemble it as follows:

- On the self-adhesive plate (4), find the assembly position of the stop bolts in relation to the circuit-breaker which has to be housed in the fixed part
- Insert the hexagonal-head screws (1) in the holes found in the previous item as shown in the figure
- Fix the screws with the washers (2) and the hexagonal stops (3).
- Make sure that the anti-racking-in lock corresponding to the one installed on the fixed part is present on the circuit-breaker (moving part).
- Anti-racking-in plate on the moving part (5).

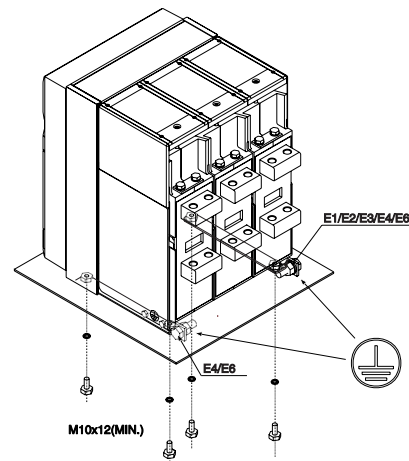

Fig. 8

Model	L2234		Apparatus	Emax	Scale
			Doc.No.	1SDH000460R0002	Page No. 8/155

Example for E1B 08 according to the nameplate diagram

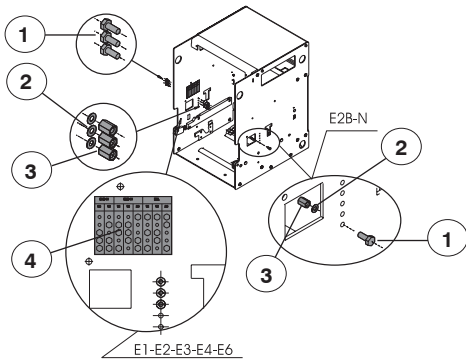

Fig. 9

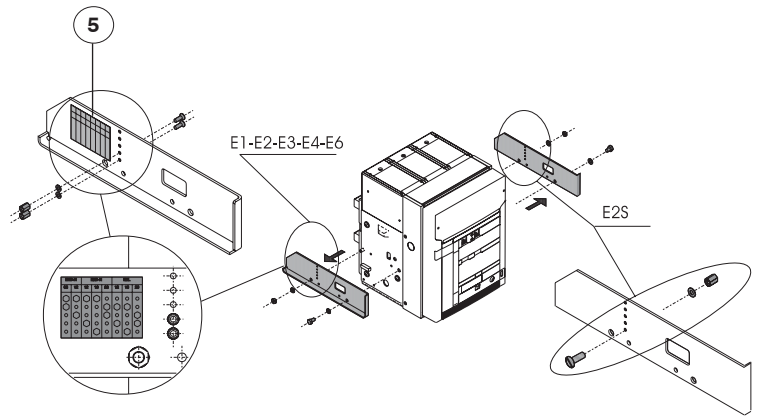

Fig. 10

4.3.2 Installation of the fixed part (Fig. 12)

Attach the fixed part by means of the screws (1), washers (2) and nuts (3) (M8 x 16), supplied by ABB SACE. If other screws are used, make sure that the head of the screws does not extend more than 5.5 mm from the base of the fixed part.

4.3.3 Installation of the fixed part on board a ship (Fig. 11)

Regarding the fixing points of the SACE Emax withdrawable version air circuit-breakers, for applications on board a ship, additional fixing on the sides of the fixed part itself is recommended (the M12 screws and the spacers are not provided in the supply).

E1 - E2 - E3

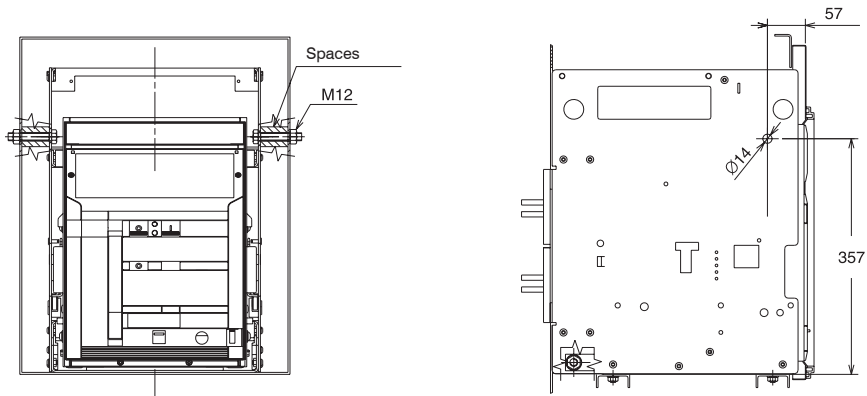

E4 - E6

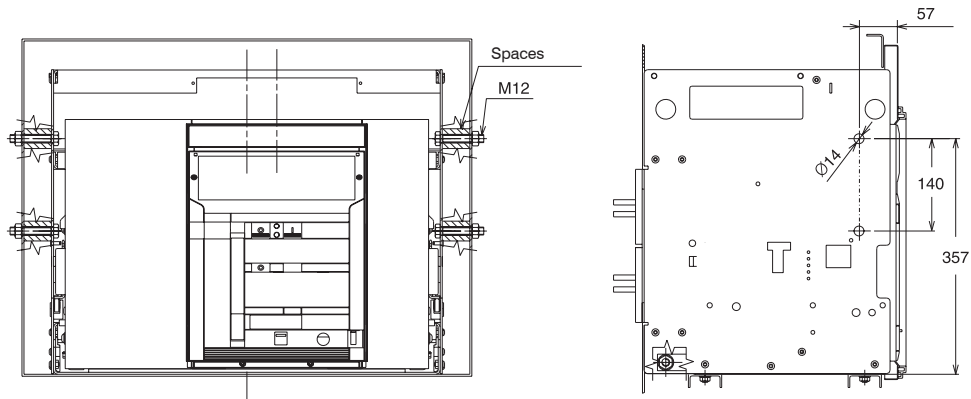
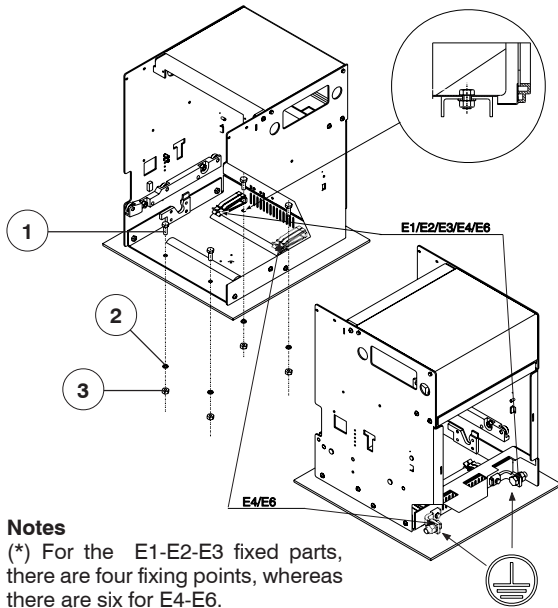

Fig. 11

Model	L2234		Apparatus	Emax	Scale
			Doc. No.	1SDH000460R0002	Page No. 9/155

4.4 Installation of the flange on the compartment door (Fig. 13)

- Make the compartment door drillings specified in the "Overall dimensions" paragraph.
- Attach the flange (1) on the front of the compartment door, fixing it from the inside by means of the self-tapping screws (2).



Notes

(*) For the E1-E2-E3 fixed parts, there are four fixing points, whereas there are six for E4-E6.

Fig. 12

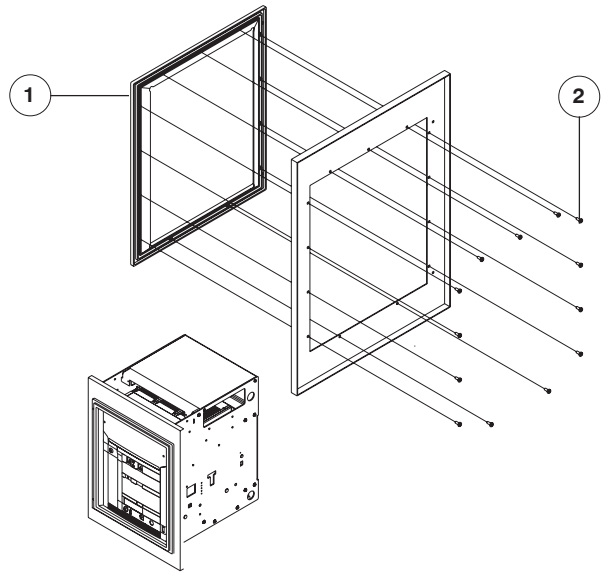

Fig. 13

5. Electrical connections

5.1 Connections to the power circuit

5.1.1 Shapes of the terminals

Fixed circuit-breaker

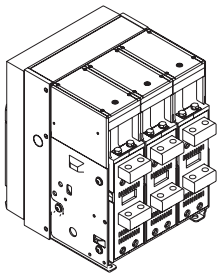

Horizontal rear terminals

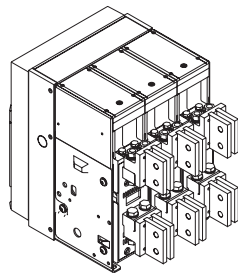

Vertical rear terminals

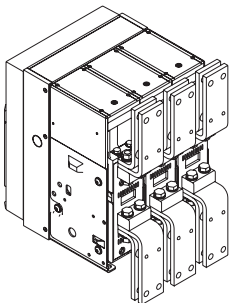

Front terminals

Fixed part for withdrawable circuit-breaker

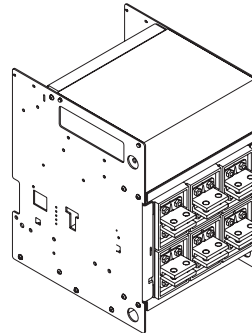

Horizontal rear terminals

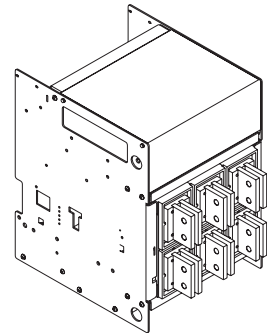

Vertical rear terminals

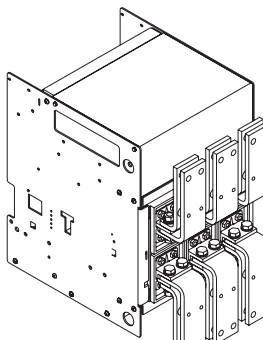

Front terminals

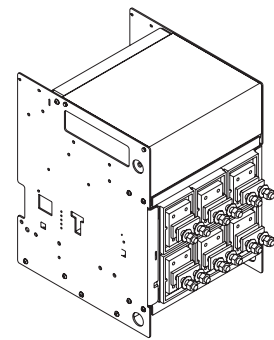

Flat terminals

Fig. 14

Fig. 15

Note

The drawings are provided to show the type of terminal in graphic form. The exact shape of the terminals is given in the "Overall dimensions" chapter. Different terminals can be installed between the top and bottom parts (inlet and outlet).

Model	L2234		Apparatus	Emax	Scale
			Doc.No.	1SDH000460R002	Page No. 10/155

5.1.2 Examples of positioning the connection busbars according to the types of terminals

The connection busbars enable the connection between the terminals of the circuit-breakers and the busbars of the switchgear. Their sizing must be carefully studied by the switchgear designer. Some examples of possible constructions in relation to the shape and size of the circuit-breaker terminals are given in this paragraph. The various types of terminals are of constant dimensions for each size of circuit-breaker: it is normally advisable to exploit the whole contact surface of the terminal, so the width of the connection busbars should be the same as that of the terminal. Different connection capacities can be obtained by adjusting the thickness and number of busbars in parallel. In some cases, reductions in the width of the connection in relation to that of the terminal are allowable as shown in the following examples.

Sections	Iu [A]	Vertical terminals				Horizontal and front terminals			
		Continuous current-carrying capacity [A][mm ²]			Busbar cross-section	Continuous current-carrying capacity [A][mm ²]			Busbar cross-section
		35°C	45°C	55°C		35°C	45°C	55°C	
E1B/N 08	800	800	800	800	1x(60x10)	800	800	800	1x(60x10)
E1B/N 10	1000	1000	1000	1000	1x(80x10)	1000	1000	1000	2x(60x8)
E1B/N 12	1250	1250	1250	1250	1x(80x10)	1250	1250	1200	2x(60x8)
E1B/N 16	1600	1600	1600	1500	2x(60x10)	1550	1450	1350	2x(60x10)
E2S 08	800	800	800	800	1x(60x10)	800	800	800	1x(60x10)
E2N/S 10	1000	1000	1000	1000	1x(60x10)	1000	1000	1000	1x(60x10)
E2N/S 12	1250	1250	1250	1250	1x(60x10)	1250	1250	1250	1x(60x10)
E2B/N/S 16	1600	1600	1600	1600	2x(60x10)	1600	1600	1530	2x(60x10)
E2B/N/S 20	2000	2000	2000	1800	3x(60x10)	2000	2000	1750	3x(60x10)
E2L 12	1250	1250	1250	1250	1x(60x10)	1250	1250	1250	1x(60x10)
E2L 16	1600	1600	1600	1500	2x(60x10)	1600	1500	1400	2x(60x10)
E3H/V 08	800	800	800	800	1x(60x10)	800	800	800	1x(60x10)
E3S/H 10	1000	1000	1000	1000	1x(60x10)	1000	1000	1000	1x(60x10)
E3S/H/V 12	1250	1250	1250	1250	1x(60x10)	1250	1250	1250	1x(60x10)
E3S/H/V 16	1600	1600	1600	1600	1x(100x10)	1600	1600	1600	1x(100x10)
E3S/H/V 20	2000	2000	2000	2000	2x(100x10)	2000	2000	2000	2x(100x10)
E3N/S/H/V 25	2500	2500	2500	2500	2x(100x10)	2500	2450	2400	2x(100x10)
E3N/S/H/V 32	3200	3200	3100	2800	3x(100x10)	3000	2880	2650	3x(100x10)
E3L 20	2000	2000	2000	2000	2x(100x10)	2000	2000	1970	2x(100x10)
E3L 25	2500	2500	2390	2250	2x(100x10)	2375	2270	2100	2x(100x10)
E4H/V 32	3200	3200	3200	3200	3x(100x10)	3200	3150	3000	3x(100x10)
E4S/H/V 40	4000	4000	3980	3500	4x(100x10)	3600	3510	3150	6x(60x10)
E6V 32	3200	3200	3200	3200	3x(100x10)	3200	3200	3200	3x(100x10)
E6H/V 40	4000	4000	4000	4000	4x(100x10)	4000	4000	4000	4x(100x10)
E6H/V 50	5000	5000	4850	4600	6x(100x10)	4850	4510	4250	6x(100x10)
E6H/V 63	6300	6000	5700	5250	7x(100x10)	-	-	-	-

Fig. 16

Positioning the first anchoring baffle of the busbars according to the short-circuit current

Anchoring to the switchgear

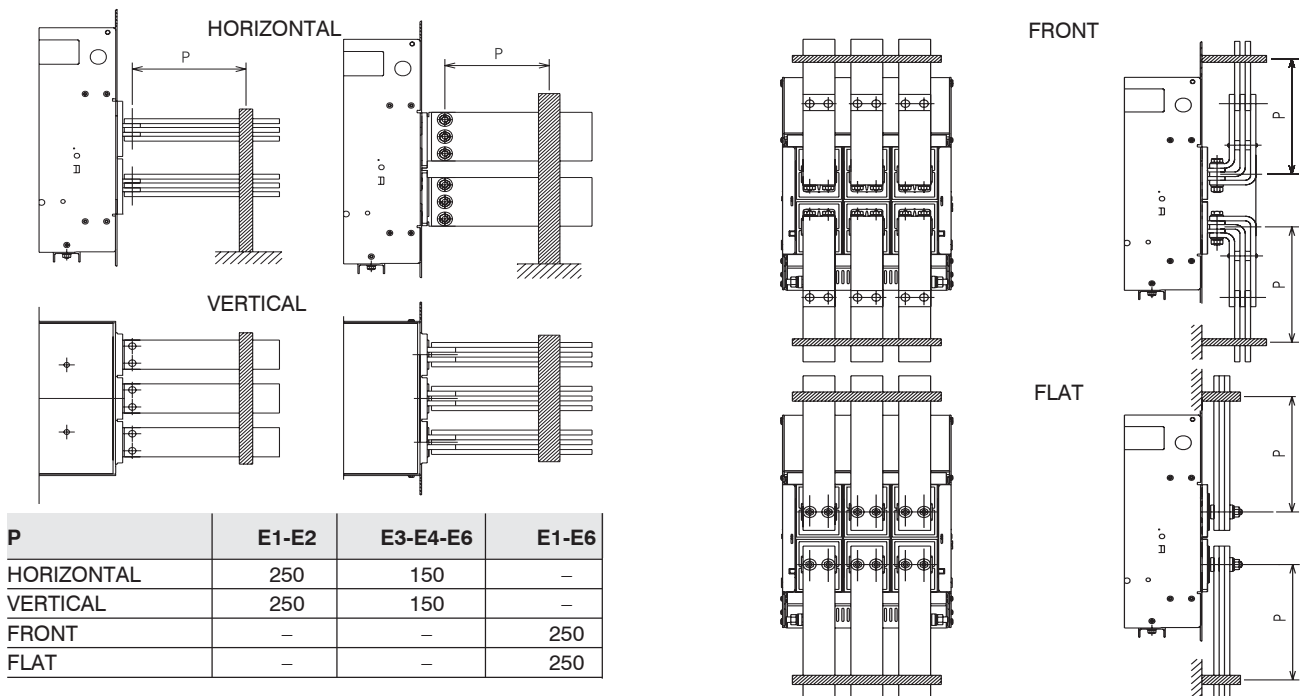

Fig. 17

Model	L2234	Apparatus	Emax	Scale
		Doc. No.	1SDH000460R0002	Page No. 11/155

5.1.3 Assembly procedure for the connection busbars

Check the state of the contact surfaces of the connections very carefully: they must be very clean with no burrs, dents or traces of rust which must be eliminated using a fine file or an emery cloth to prevent localized increases in temperature. On completion of the operation, remove all traces of grease or dust with a cloth soaked in a suitable solvent. When copper connections are used, it is advisable to tin-plate the contact surfaces. When aluminium connections are used, it is advisable to apply a thin layer of Vaseline over the contact surfaces.

The connections must not exert any strain on the terminals in any direction.

Always insert a large-diameter flat washer and a spring washer between them (to spread the tightening pressure over a greater area).

Make the contact between connection and terminal and tighten the fixing screws completely.

Always use two wrenches (so as not to strain the insulating parts excessively), applying the tightening torque indicated in Fig. 18. Check tightness after 24 hours.

M12 high strength screws

Tightening torque of the main terminals: 70 Nm

Fixed part terminals	No. of screws for phase	No. of screws for neutral	Fixed circuit-breaker terminals	No. of screws for phase	No. of screws for neutral
	E1/E2 → 2	2		E1/E2 → 2	2
	E3 → 3	3		E3 → 3	3
	E4 → 4	2		E4 → 4	2
	E4/f → 4	4		E4/f → 4	4
	E6 → 6	3		E6 → 6	3
	E6/f → 6	6		E6/f → 6	6

Fig. 18

5.2 Earthing

The fixed circuit-breaker and the fixed part of the withdrawable circuit-breaker have one or two terminals on the rear, marked with the special symbol, for connection to earth (Fig. 9 and Fig. 12b).

Each terminal is complete with a bolt for fixing the connection. A conductor with a cross-section conforming to current standards must be used for the connection.

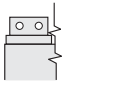
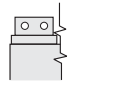
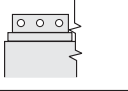
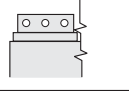
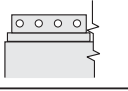
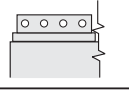
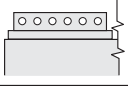
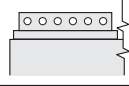
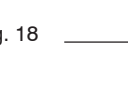
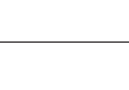
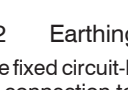
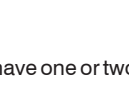
Before assembling the connection, clean and degrease the area around the screw.

After the assembly, tighten the bolt with a torque of 70 Nm.

5.3 Wiring the circuit-breaker auxiliary circuits

5.3.1 Interfacing elements for fixed circuit-breakers

A special terminal box is provided, fitted with screw terminals for connecting the auxiliary circuits.

The terminals are marked with alphanumeric identification codes as for the electrical circuit diagram.

The terminal box is identified by code XV on the electrical circuit diagram.

The terminal box is immediately accessible when the compartment door is open.

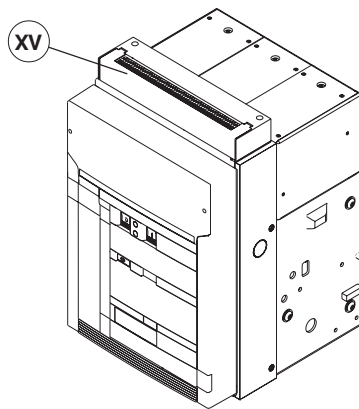

Fig. 19

Model	L2234		Apparatus	Emax	Scale
			Doc.No.	1SDH000460R0002	Page No. 12/155

5.3.2 Withdrawable circuit-breaker

For connection of the moving part to the auxiliary circuits, a connection with sliding contacts is available on the fixed part (see figure), identified by code X on the electrical circuit diagram.

The terminals of the fixed connector are immediately accessible when the compartment door is open.

Furthermore a terminal box identified by code XF is available for connecting the position contacts of the moving part in relation to the fixed part. The connector and terminal box have screw terminals.

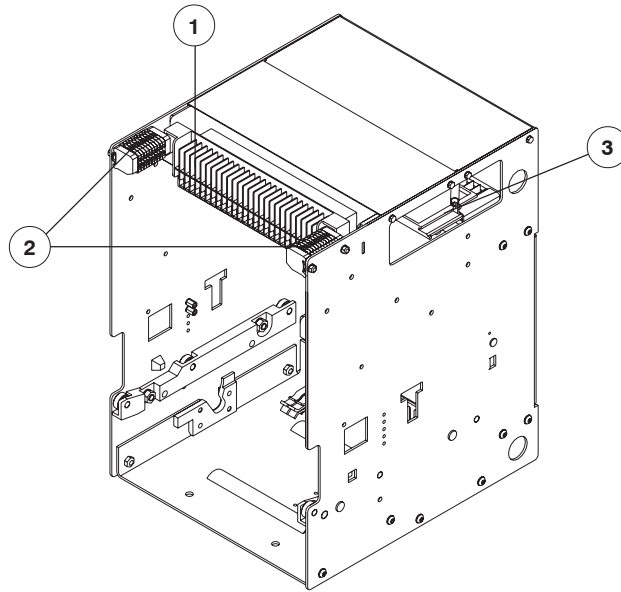

E1 - E2 - E3
10 contacts in position

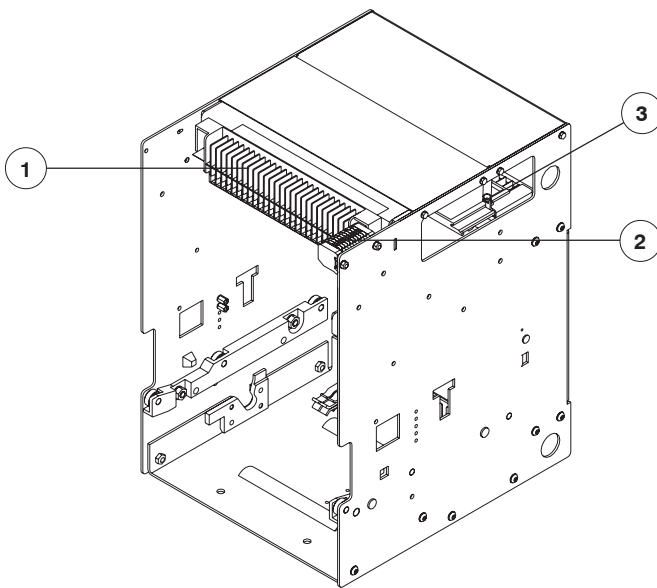

E1 - E2 - E3 - E4 - E6
5 contacts in position

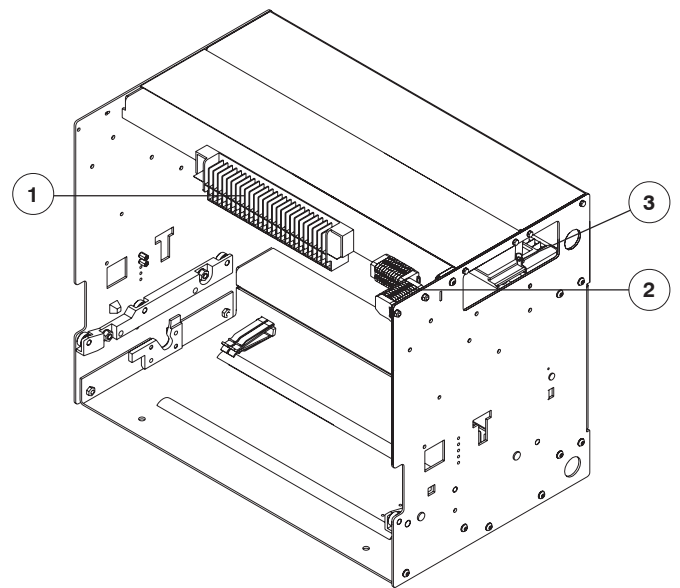

E4 - E6
10 contacts in position

Caption

- ① Sliding contacts(X)
- ② Terminal box for position contacts (XF)
- ③ Position contacts

Fig. 20

Model	L2234		Apparatus	Emax	Scale
			Doc. No.	1SDH000460R0002	Page No. 13/155

5.4 Conversion of the auxiliary contacts or of the signalling contacts (disconnected - test isolated - connected), from normally closed (opening) to normally open (closing) or vice versa

The contacts are wired at the factory as shown on the electrical circuit diagram. If it is necessary to change their state for installation requirements, proceed as follows.

a) Auxiliary contacts

To access the auxiliary contacts, carry out the following operations.

- remove the front protection (3) of the release by taking action on the blocks (1) as shown in the figure
- remove the protection release (4) removing the side nuts (2) and then sliding the release out from the front of the circuit-breaker.

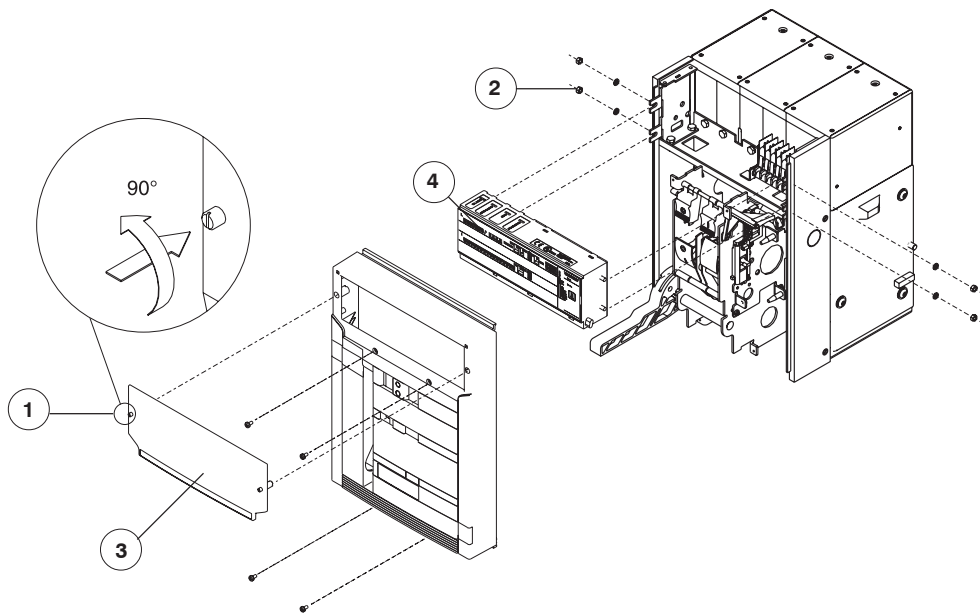
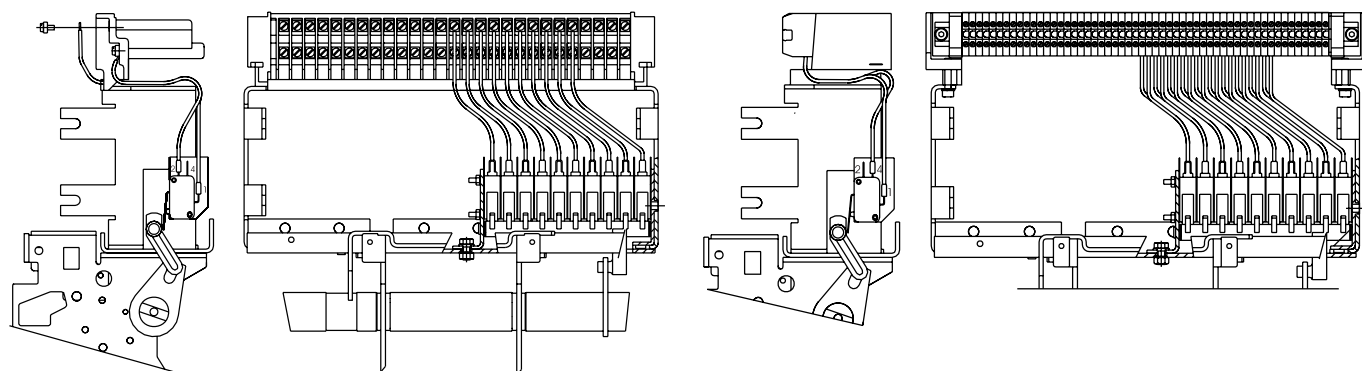

Fig. 21

Being of the two-way type (changeover contacts), the auxiliary contacts can be modified from break contacts to make contacts and vice versa simply by moving the output conductor from one position to the other, as shown in the figure (example for PR121).



N.C. contact

Sliding contacts

N.O. contact

Terminal box

Fig. 22

b) Position contacts disconnected - test isolated - connected

To change the state of the position contact, proceed in the same way as explained for the auxiliary contacts.

Model	L2234		Apparatus	Emax	Scale
			Doc.No.	1SDH000460R002	Page No. 14/155

6. Putting into service

6.1 General procedures

- Check tightness of the power connections at the circuit-breaker terminals
- Carry out all the preparatory operations on the release
- Make sure that the value of the auxiliary circuit power supply voltage is between 85 and 110% of the rated voltage of the electrical applications
- Make sure that there is an adequate air circulation in the place of installation to avoid overheating
- Also carry out the checks specified in the following table

Item inspected	Procedure	Positive check
1 Manual operating mechanism	Carry out some opening and closing operations (see the chapter 7.2). CAUTION When there is an undervoltage release, the circuit-breaker can only be closed after the release has been electrically energized.	The spring loading lever moves correctly.
2 Geared motor (if any)	Supply the spring loading geared motor at the corresponding rated voltage. Carry out some closing and opening operations. Note. Supply the undervoltage release at the corresponding rated voltage (if any)	The springs are loaded correctly. The signals are correct. The geared motor stops with the springs loaded. The geared motor recharges the springs after each closing operation.
3 Undervoltage release (if any)	Supply the undervoltage release at the corresponding rated voltage and carry out the circuit-breaker closing operation. Disconnect voltage to the release. Supply the undervoltage release at the corresponding rated voltage and carry out the circuit-breaker closing operation.	The circuit-breaker closes correctly. The signals are correct. The circuit-breaker opens. The signal changes over.
4 Shunt opening release (if any)	Close the circuit-breaker. Supply the shunt opening release at the corresponding rated voltage	The circuit-breaker opens correctly. The signals are correct.
5 Shunt closing release (if any)	Open the circuit-breaker. Supply the shunt closing release at its rated voltage.	The circuit-breaker closes correctly. The signals are correct.
6 Circuit-breaker lock in the open position (with key or padlocks)	Open the circuit-breaker, turn the key and remove it from its seat. Attempt the circuit-breaker closing operation.	Both manual and electrical closing are prevented.
7 Auxiliary contacts of the circuit-breaker	Insert the auxiliary contacts in suitable signalling circuits. Carry out some circuit-breaker closing and opening operations.	The signals are given correctly.
8 Auxiliary contacts for signalling circuit-breaker connected, test isolated and disconnected	Insert the auxiliary contacts in suitable signalling circuits. Then put the circuit-breaker in the connected, test isolated and disconnected position.	The signals due to the relative operations are given correctly.
9 Lock devices for circuit-breakers connected and disconnected. Interlocking devices between circuit-breakers side by side and one on top of another (if any)	Carry out the operating tests.	The locks function correctly.
10 For withdrawable circuit-breakers: racking -in/out device	Carry out some racking-in and out operations.	Racking-in operation: the circuit-breaker racks in correctly. The first turns of the crank handle do not meet with particular resistance.

Model	L2234		Apparatus	Emax	Scale
			Doc. No.	1SDH000460R0002	Page No. 15/155

7. Instructions for use

7.1 Operating and signalling parts

- 1 Pushbutton for the manual opening operation
- 2 Lever for manual loading of the closing springs
- 3 Mechanical indicator for circuit-breaker open "O" and closed "I"
- 4 Mechanical indicator for protection release tripped (on request)
- 5 Pushbutton for the manual closing operation
- 6 Signalling device for springs loaded - unloaded
- 7 Operation counter (on request)
- 8 Key lock on the closing operation
- 9 Mechanical indicator for circuit-breaker connected, test isolated and disconnected
- 10 Seat for the racking-in/out lever
- 11 Lever releasing the racking-in/out operation
- 12 Key lock on the racking-in/out operation (on request)
- 13 Padlock on the manual closing operation (on request)
- 14 Padlock on the racking-in/out operation (on request)

Fixed circuit-breaker

Withdrawable circuit-breaker

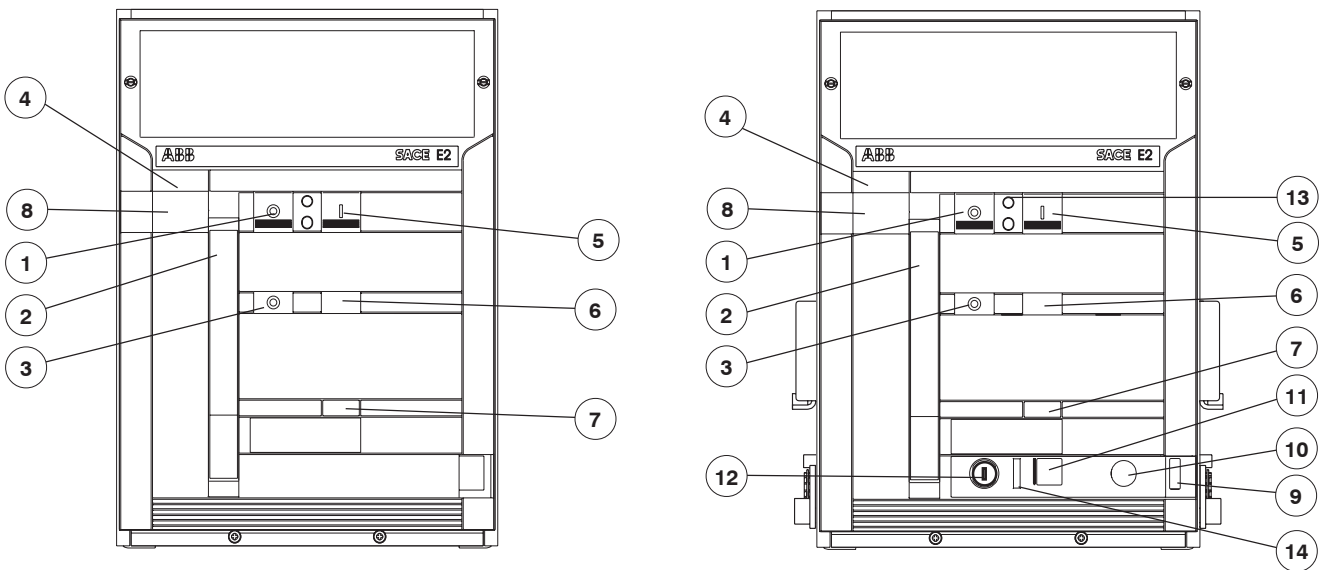

Fig. 23

Note

On request, a transparent cover can be installed on the front of the circuit-breaker to increase the degree of protection to IP54. The cover has a locking key.

As an alternative to the transparent cover, a protection can be mounted on the manual closing and opening controls, which only allows operation of the pushbuttons by means of a special tool.

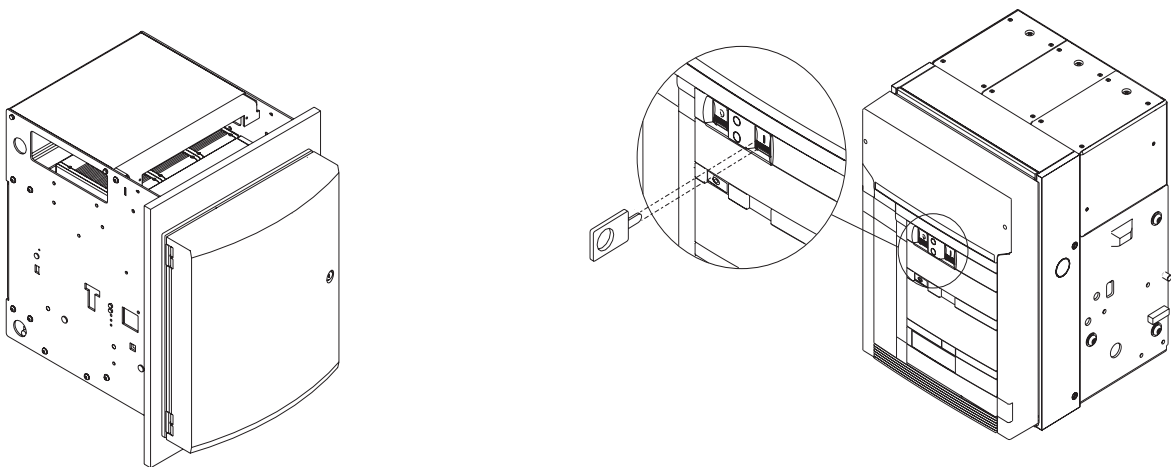

Fig. 24

Model	L2234		Apparatus	Emax	Scale
			Doc.No.	1SDH000460R0002	Page No. 16/155

7.2 Circuit-breaker closing and opening procedures

The operation of the circuit-breaker can be either manual or electrical.

a) Manual loading of the closing springs

- Make sure that the indicator (3) shows "O" (circuit-breaker open)
- Make sure that the indicator (6) is WHITE (springs unloaded)
- Repeatedly activate the lever (2) until the indicator (6) changes its color to YELLOW

b) Electrical loading of the closing springs

The electrical loading of the circuit-breaker is possible when the following accessories (supplied on request) are present:

- geared motor for automatic loading of the closing springs
- shunt closing release
- shunt opening release.

The geared motor automatically reloads the springs after each closing operation until the yellow indicator appears (6, Fig. 25). When the power is cut off during loading, the geared motor stops and automatically starts reloading the springs again when the power returns. It is, in any case, always possible to complete the reloading operation manually.

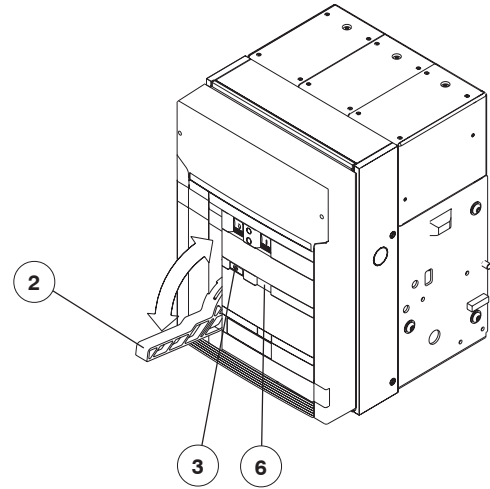

Fig. 25

c) Closing the circuit-breaker

The operation can only be carried out with the closing springs fully loaded. For manual closing, press the pushbutton (5) marked with the letter "I". When there is a shunt closing release, the operation can be carried out remotely by means of the special control circuit. The special indicator (3) changes to indicate "I" to signal that the circuit-breaker has closed. Furthermore, the indicator of the state of the springs (6) goes to the WHITE position. Even with the closing springs unloaded, the operating mechanism retains enough energy for the opening operation. The geared motor, if any, immediately starts the automatic spring reloading operation.

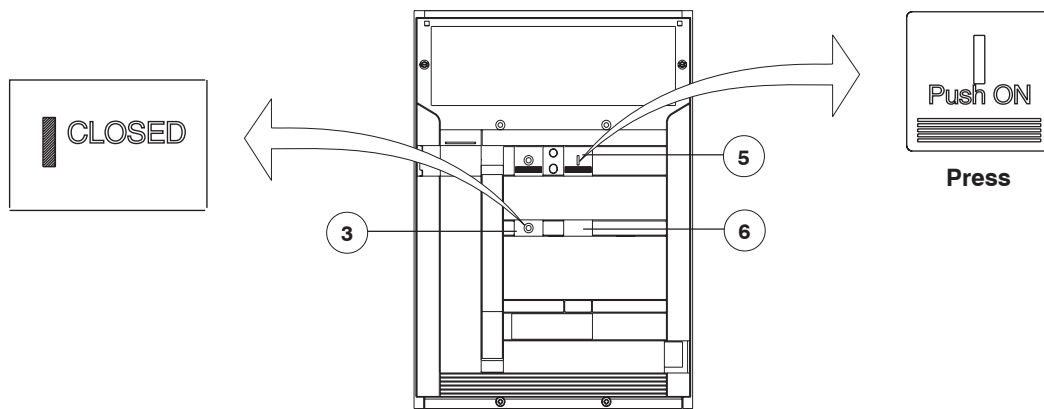

Fig. 26

d) Opening the circuit-breaker

For manual opening of the circuit-breaker, press pushbutton "O" (1). When there is a shunt opening release, the operation can also be carried out remotely by means of the special control circuit. Opening having taken place is signaled by the letter "O" appearing in the indicator (3).

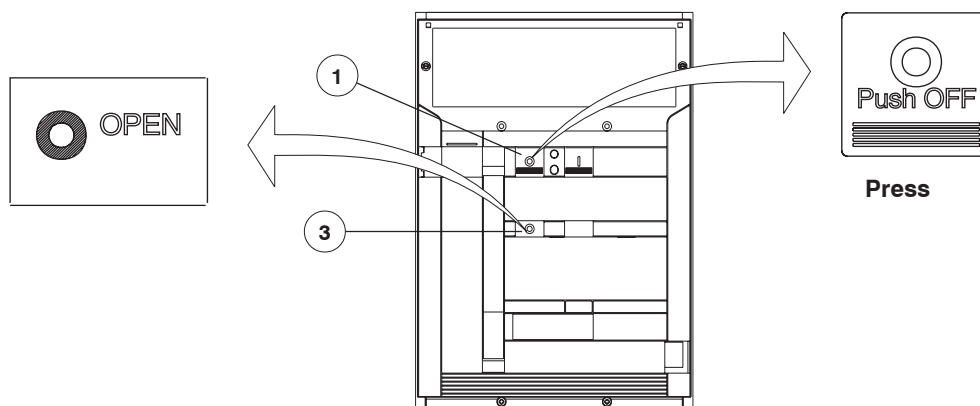

Fig. 27

Model	L2234		Apparatus	Emax	Scale
			Doc. No.	1SDH000460R0002	Page No. 17/155

7.3 Racking-in/out operation

WARNING

- A) Open the circuit-breaker before carrying out any racking-in/out operation.
- B) The circuit-breaker (moving part) and fixed part are fitted with a lock which prevents the fixed part from being racked into the circuit-breakers with a different rated current: the congruence of the anti-racking-in lock must be checked by the operator before carrying out the racking-in operation to avoid any unnecessary stress.
- C) Before the racking-in operation, remove any padlock on the segregation shutter of the isolation terminals on the fixed part.

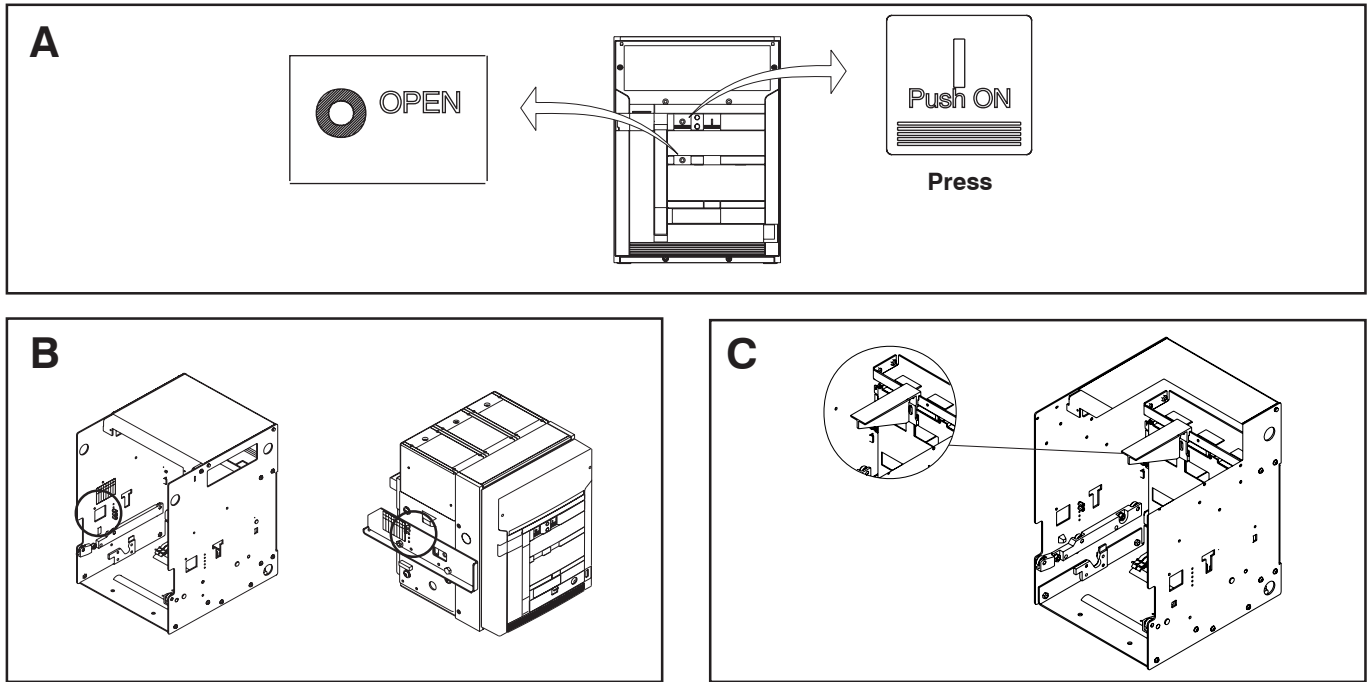

Fig. 28

NOTES

In relation to the fixed part, the circuit-breaker (moving part) can take up different positions, identified as follows:

- **DISCONNECTED:** the moving part is inserted in the fixed part **WITHOUT** any connection between the terminals and **WITHOUT** coupling the sliding contacts for the auxiliary circuits: in this position all electrical operation of the circuit-breaker is prevented. On the front the indicator (9, Fig. 23) indicates **DISCONNECTED**. The switchgear compartment door can be closed.
- **TEST ISOLATED:** the moving part is inserted in the fixed part **WITHOUT** any connection between the power terminals, but **WITH** the sliding contacts coupled for the auxiliary circuits. In this position, the circuit-breaker can be operated for the offline tests. The indicator (9, Fig. 23) indicates **TEST ISOLATED**.
- **CONNECTED:** the moving part is fully inserted in the fixed part **WITH** the connection of both the power terminals and the sliding contacts for the auxiliary circuits. The circuit-breaker is operational. The indicator (9, Fig. 23) indicates **CONNECTED**.

a) Positioning the moving part in the fixed part in the DISCONNECTED position

Lift the moving part as shown in the paragraph (3) and insert it in the fixed part guide, tilting it as shown in figure 29.

The manual connection must allow the edge (E) of the circuit-breaker guide to slide under the blocks (D) of the fixed part. Remove the lifting devices.

The position reached is stable and allows for any inspections of the circuit-breaker.

Push the moving part as far as the stop in the fixed part. Close the compartment door.

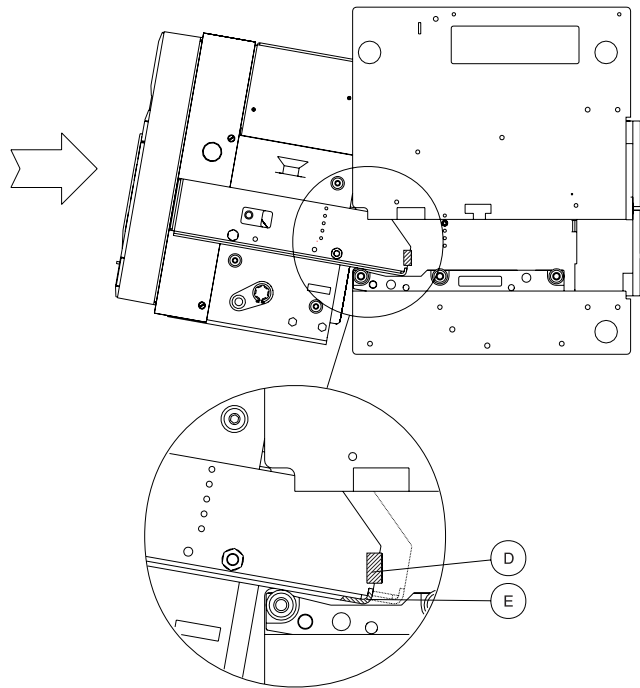

Fig. 29

Model	L2234		Apparatus	Emax	Scale
			Doc.No.	1SDH000460R002	Page No. 18/155

b) Passing from the DISCONNECTED to the TEST ISOLATED position

Make sure that the indicator (9) is in the DISCONNECTED position.
 For the connection procedure, make sure that the key (12) is in the correct position and/or the padlock (14), if any, has been removed.
 Make sure that the circuit-breaker is open.
 Push the moving part right into the fixed part.
 Lower the releasing lever (11).
 Insert the crank handle in the corresponding coupling (10).
 Proceed to turn the crank handle clockwise until the TEST ISOLATED indication appears on the indicator (9). During the initial turns, the crank handle must oppose no any particular resistance to rotation.
 Should it be necessary to carry out offline circuit-breaker operations, the crank handle must be removed.

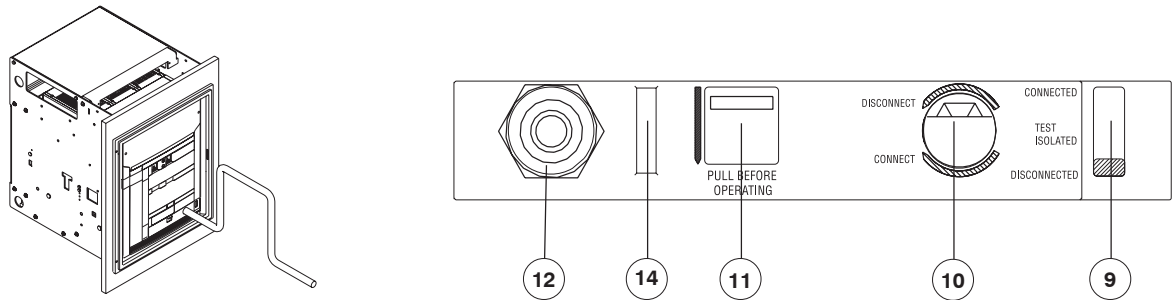

Fig. 30

c) Passing from the TEST ISOLATED position to the CONNECTED position

Make sure that the circuit-breaker is open.
 Lower the releasing lever (11).
 Insert the crank handle in the corresponding coupling (10).
 Proceed to turn the crank handle clockwise until the CONNECTED indication appears on the indicator (9).
 Remove the crank handle to enable the circuit-breaker to close.

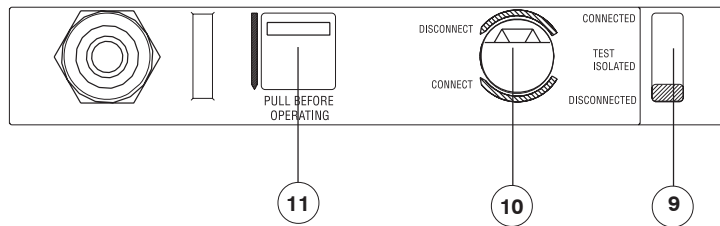

Fig. 31

d) Passing from the CONNECTED position, to the TEST ISOLATED position, to the DISCONNECTED position

Repeat the connection procedures changing the direction for turning the crank handle to anti-clockwise. Open the door in the disconnected position.

8. Maintenance

8.1 Warning

Before carrying out any maintenance work, it is necessary to complete the following procedure:

- open the circuit-breaker and check that the operating mechanism springs are unloaded
- in the case of withdrawable circuit-breakers, work with the circuit-breaker racked-out of the fixed part
- for action on fixed version circuit-breakers or on fixed parts of withdrawable circuit-breakers, disconnect the supply to the power circuit and to the auxiliary circuits. Furthermore, visibly earth the terminals both on the power supply side and on the load side.

During normal service, the circuit-breakers require limited maintenance.

The table of the maintenance program is given in the following paragraph, indicating the corresponding periodic intervals for action. In particular, with regard to the time intervals, it is advisable to follow the recommendations in the table, at least for the first year of service. On the basis of the results obtained during the routine checks, establish the best time intervals for the maintenance operations.

It is also advisable to refer to the following rules:

- circuit-breakers which rarely operate, or which remain closed for long periods, must be operated from time to time to avoid any tendency to stick
 - during service, routinely inspect the circuit-breaker from the outside to check for any dust, dirt or damage of any kind.
- For circuit-breakers with SACE PR122 and SACE PR123 releases, check the percentage of wear on the contacts.
 For circuit-breakers fitted with SACE PR121 releases, installation of the mechanical operation counter (supplied on request) is recommended. The SACE PR122 and SACE PR123 releases allow for the number of operations performed by the circuit-breaker in service to be displayed at all times on the special display.

Model	L2234		Apparatus	Emax	Scale
			Doc. No.	1SDH000460R0002	Page No. 19/155

With regular maintenance, SACE Emax circuit-breakers, either with or without a geared motor, can withstand the following operation without replacement of parts.

Rated uninterrupted current I _u (40°C) [A]	Mechanical life (*)		Electrical life		
	N° of operations x 1000	Frequency operations/hour	440 V ~ N° of operations x 1000	690 V ~ N° of operations x 1000	Frequency operations/hour
E1 B-N	800	25	60	10	30
	1000-1250	25	60	10	30
	1600	25	60	10	30
E2 B-N-S	800	25	60	15	30
	1000-1250	25	60	15	30
	1600	25	60	12	30
	2000	25	60	10	30
E2 L	1250	20	60	4	20
	1600	20	60	3	20
E3 N-S-H-V	800	20	60	12	20
	1250	20	60	12	20
	1600	20	60	10	20
	2000	20	60	9	20
	2500	20	60	8	20
	3200	20	60	6	20
E3 L	2000	15	60	2	20
	2500	15	60	1,8	20
E4 S-H-V	3200	15	60	7	10
	4000	15	60	5	10
E6 H-V	3200	12	60	5	10
	4000	12	60	4	10
	5000	12	60	3	10
	6300	12	60	2	10

(*) With regular ordinary maintenance

8.2 Maintenance program

Maintenance operations	Interval	
	Installations in normal rooms	Installations in dusty or polluted rooms
General inspection (see par. 8.3.2)	One year or after a short-circuit trip	Six months or after a short-circuit trip
External visual check and inspection of the power section	One year	Six months
Operating mechanism maintenance (par. 8.3.4)	One year or 10000 operations	Six months or 10000 operations
Checking trip of the release	One year	Six months

8.3 Maintenance operations

8.3.1 Preliminary operations

- Remove the flange (1) of the release, turning the screws (2) as shown in the figures
- Remove the front escutcheon plate (3) by removing the four screws (4)
- Remove, if present, one or both side guards (5) by removing the front (6) and lateral (7) screws
- Remove the arcing chambers (8) by removing the screws (9).

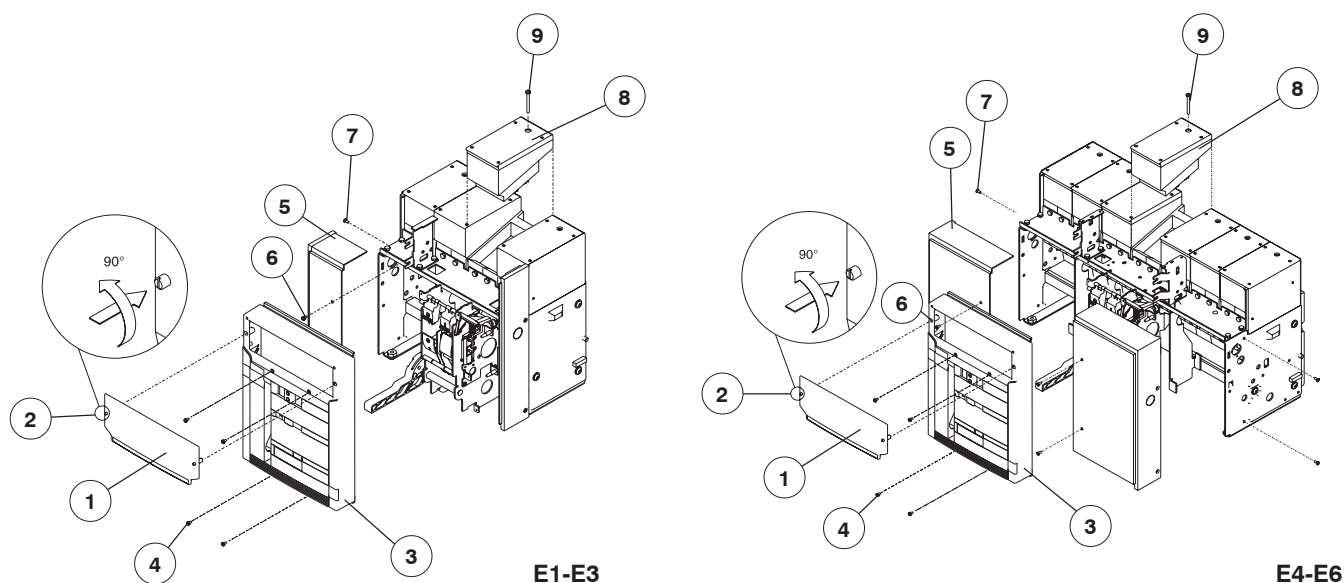

Fig. 32

Model	L2234		Apparatus	Emax	Scale
			Doc.No.	1SDH000460R0002	Page No. 20/155

8.3.2 General inspection of the circuit-breaker

Item to be inspected	Problem found	Remedy
1 Operating mechanism/Electrical accessories	<ul style="list-style-type: none"> - Presence of dust on the internal parts - Springs deformed or rusty - Safety rings out of place, nuts or screws loose - Wires and straps detached 	<ul style="list-style-type: none"> - Clean with brushes or dry cloths - Replace damaged springs - Put the rings back in place and tighten screws and nuts appropriately - Replace the straps and connect the detached wires correctly
2 Arcing and main contacts	<ul style="list-style-type: none"> - Traces of wear - Incorrect adjustments: distance A - Fig. 33 is less than 1mm for E1-E2-E3 or less than 0.8 mm for E4-E6 	<ul style="list-style-type: none"> - Smooth the contacts with emery cloth - Adjust according to the paragraph 8.3.3
3 Arcing chambers	<ul style="list-style-type: none"> - Presence of fumes or dust - Presence of cracks in the external plastic structure - Excessive difference in wear between the first and last arc extinguishing plate 	<ul style="list-style-type: none"> - Remove with compressed air and remove the fumes and any slag with a brush - Replace the arcing chamber - Replace the arcing chamber
4 Main circuit - Busbars - Insulating contacts	<ul style="list-style-type: none"> - Presence of dust or dirt on the insulating parts - Safety rings out of place, screws or nuts loose - Deformation or cracks of the insulating parts - Insulating contacts oxidized (only for withdrawable circuit-breaker) - Screws loose on the connections to the terminals of the circuit-breaker (only for fixed circuit-breaker) 	<ul style="list-style-type: none"> - Clean with a brush or dry cloths - Put the rings back in place and tighten screws and nuts appropriately - Ask ABB SACE to replace the damaged parts - Remove the shutters and clean with a rough clothsoaked in a suitable solvent and lubricate moderately with neutral grease - Tighten the screws suitably
5 Earthing contacts (only for withdrawable circuit-breaker)	Presence of rust or loose nuts	Clean with a rough cloth soaked in a suitable solvent and lubricate moderately with neutral grease. Tighten the nuts completely
6 Earth connection (only for fixed circuit-breaker)	Presence of rust and/or loose nuts	Clean with a rough cloth soaked in a suitable solvent, fully tighten the earth connection and cover with neutral grease again
7 Auxiliary circuit power supply voltage	Check the power supply voltage of the electrical accessories of the operating mechanism	The releases and locking devices must operate normally for values between 85% and 110% of the corresponding rated voltage
8 Operating and control parts	The operating tests, which must be carried out as shown in paragraph 6.1 have shown defects in the components	Replace the defective parts or those with a faulty operation (if necessary, ask ABB SACE)

8.3.3 Checking contact wear

In order to ensure the gap A indicated in the table, you can adjust the position of the shaft and of the operating mechanism.

- 1) Open the circuit-breaker
- 2) Remove the arcing chamber
- 3a) Adjust the distance of the moving contacts for E1-E2-E3:
 - loosen the screws in pos.1 and the nuts in pos. 3 (FIG 33 a)
 - proceed in the same way on the screws in pos. 2
 - bring the bushes of the operating mechanism (pos. 5) to rest on the shaft, tacking action on the nuts in pos. 4
 - tighten the screws in pos.1 and the nuts in pos. 3 and 4
 - close the circuit-breaker and check the gap A
- 3b) Adjust the distance of the moving contacts detachment for E4-E6:
 - loosen the screws in pos.1 and 6, the nuts in pos 3. and 8 (FIG 33 a and 33 b)
 - proceed in the same way on the screws in pos. 2
 - bring the bushes of the operating mechanism (pos. 5) and the bushes of the intermediate abutments (pos. 9) to rest on the shaft, tacking action on the nuts in pos.4 and the screws in position 7
 - tighten the screws in pos.1 and 6, and the nuts in pos. 3, 4 and 8
 - close the circuit-breaker and check the gap A
- 4) If the gap A is not correct, open the circuit-breaker again and repeat the procedure indicated in item 3a or 3b
- 5) If the gap A is correct, open the circuit-breaker again, seal with yellow paint and reinstall the arcing chambers.

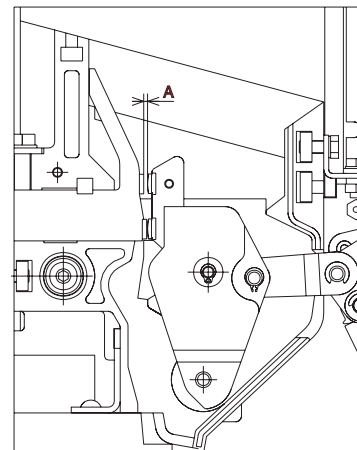

Circuit-breaker	A
E1 - E2 - E3	1 ÷ 1.9 mm
E4 - E6	0.8 ÷ 1.5 mm

Fig. 33

Model	L2234		Apparatus	Emax	Scale
			Doc. No.	1SDH000460R0002	Page No. 21/155

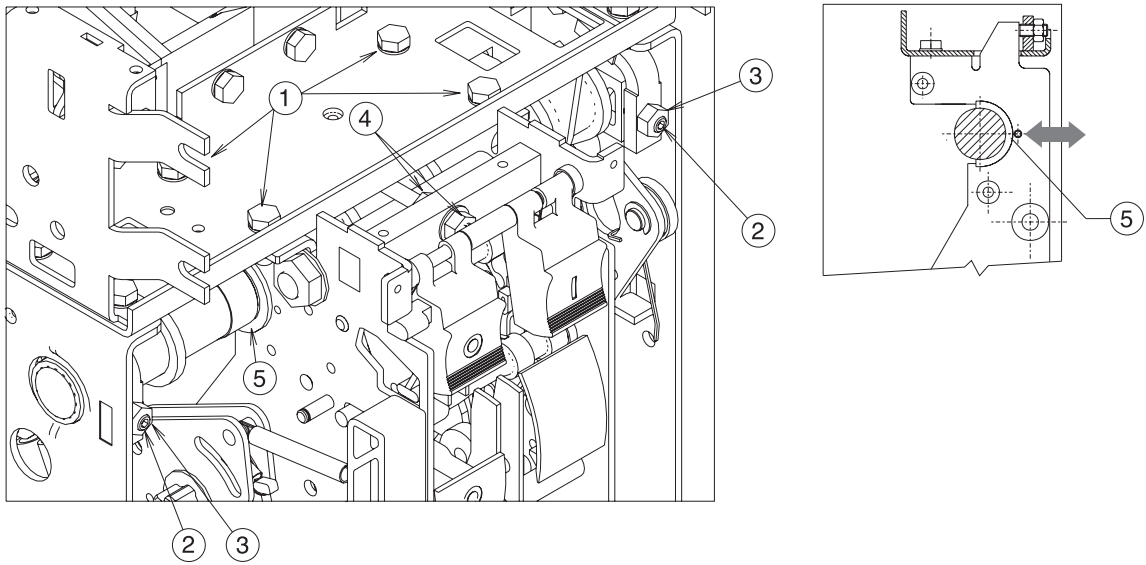

Fig. 33a

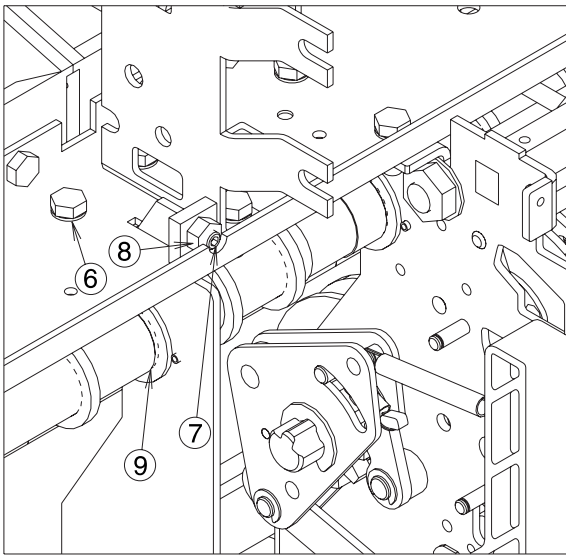

Fig. 33b

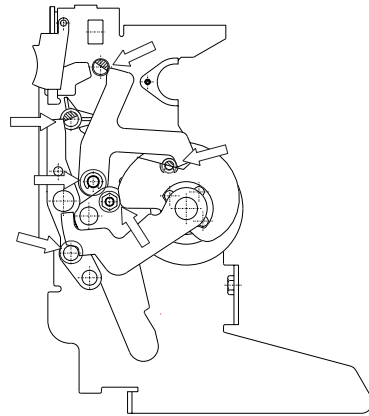

Fig. 33c

8.3.4 Operating mechanism maintenance

- Carry out the checks and take the action listed under item 1 of the table in paragraph 8.3.2.
- Lubricate the bearings of the drive shaft with MU-EP1 (AGIP) grease, including those on the sides of the circuit-breaker. Equivalent greases: ESSO Beacon EP1 - BP LTX1 - SHELL AVANIA GREASE R1 - KLUBER LUBRIFICATION CENTO PLEX 2P
- Lubricate the small opening and closing shafts and the hooks with 5 RX MOLY (OLEOTECNICA) grease (Fig. 33c). Equivalent grease: KLUBER LUBRIFICATION GRAFLOSCON A-G 1 ULTRA.

Model	L2234		Apparatus	Emax	Scale
			Doc.No.	1SDH000460R0002	Page No. 22/155

9. Measures to be taken for any operating anomalies

Pressing the i Test pushbutton on the PR122/PR123 does not cause circuit-breaker opening										Anomalies	
The WARNING or ALARM led on the PR121/PR122/PR123 release lights up											
Release coils interrupted or burnt out, geared motor winding interrupted											
The shunt opening release or shunt closing release does not energize sufficiently											
The shunt opening release or shunt closing release remains energized											
The moving part does not rack into the fixed part											
The moving part does not rack out of the fixed part											
The circuit-breaker does not close											
The circuit-breaker does not open											
										Possible causes	Checks and remedies
●										Connector XO not inserted correctly	Check and insert connector XO correctly
●										Coil of the opening release YO1 interrupted	Replace the YO shunt opening release
●										Defect in the electronic circuits of the electronic release	Put the circuit-breaker out of service and check the release with the test apparatus
●										The possible causes of tripping are listed in the part of the manual relating to the releases	Take action according to the cause: in particular, if contact wear is higher than 80% (WARNING led lit up), the circuit-breaker can remain in service, but replacement of the circuit-breaking parts must be scheduled within a short time. If contact wear reaches 100%, the circuit-breaker must be put out of service immediately. Ask ABB SACE about replacement procedures for the circuit-breaking parts.
								●		Protections not reset	Press the mechanical pushbutton for signalling protection tripping
									●	Operating mechanism or consent contacts blocked in closing position	Check the state of the contacts in series with the release circuit
●									● ●	Auxiliary circuit power supply voltage too low	Measure the voltage: it must not be less than 85% of the rated voltage
●									● ●	Different power supply voltage from the one indicated on the rating plate of the releases	Check the rating plate voltage of the releases
									● ●	Operating circuit faulty	Check connections, fuses, interlock, protection circuit-breakers and consent contacts
									● ●	Wire tightening screws loose	Check tightness of the screws connecting the wires
									● ●	Incorrect electrical connections in the power supply circuit	Check the connections with the corresponding circuit diagram
									● ●	Release coils interrupted	Replace the coils
									● ●	Operating mechanism blocked	Operate by hand. If the fault persists contact ABB SACE
									●	Key not inserted in the opening mechanism lock	Insert and turn the key
									●	Circuit-breaker in intermediate position between connected and disconnected	Complete the operation
									●	Undervoltage release not energized	Check the corresponding power supply circuit
									●	Shunt opening release remains energized	Check the power supply circuit
									● ●	Racking-in or out operation not carried out correctly	See paragraph 7.3

Model	L2234			Apparatus	Emax	Scale
				Doc. No.	1SDH000460R0002	Page No. 23/155

10. Accessories

10.1 Electrical accessories

Shunt opening/closing (YO/YC) and second shunt opening release (YO2)

This allows remote opening or closing control of the apparatus. Given the characteristics of the circuit-breaker operating mechanism, opening (with the circuit-breaker closed) is always possible, whereas closing is only possible when the closing springs are loaded. Most of the releases can operate with either direct or alternating current. This release carries out an instantaneous service (*), but can be supplied permanently (**).

In uses where the shunt closing release is supplied permanently, to carry out the circuit-breaker reclosing operation after opening, it is necessary to momentarily de-energize the shunt closing release (the circuit-breaker operating mechanism reclosing is, in fact, fitted with an antipumping device).

In some versions it is necessary to have a very high degree of safety for the remote opening control of the circuit-breaker, and, in particular, the duplication of the control circuit of the shunt opening release is required. In order to achieve this, you can fit the SACE Emax circuit-breakers with a second shunt opening release. The second shunt opening release is located in the undervoltage release and its technical characteristics are the same as the standard shunt opening release.

(*) In the case of instantaneous service, the minimum duration of the current impulse must be 100 ms.

(**) In the case of permanent power supply to the shunt opening release, you must wait for at least 30 ms before giving the opening control to the shunt closing release. Reference figures in the electrical circuit diagrams: YO (4) - YC (2) - YO2 (8)

Power supply (Un)	24 V DC	Operating limits (CEI EN 60947-2 Standards)	(YO-YO2) : 70...110% Un	
	30 V AC/DC		(YC) : 85...110% Un	
	48 V AC/DC		Inrush power consumption (Ps)	DC = 200 W
	60 V AC/DC		Inrush power time ~ 100 ms	AC = 200 VA
	110-120 V AC/DC		Continuous power (Pc)	DC = 5 W
	120-127 V AC/DC			AC = 5 VA
	220-240 V AC/DC		Opening time (YO - YO2)	(max) 60 ms
	240-250 V AC/DC		Closing time (YC)	(max) 80 ms
	380-400 V AC		Insulation voltage	2500V 50Hz (for 1 min.)
	440 V AC			

Undervoltage release (YU)

The undervoltage release opens the out circuit-breaker in the case of a considerable drop or lack of its power supply voltage. It can be used for remote tripping (by means of normally closed type pushbuttons), as a lock on closing or to control the voltage in the primary and secondary circuits. The release power supply is therefore branched on the supply side of the circuit-breaker from an independent source. Circuit-breaker closing is only allowed with the release powered (the closing lock is carried out mechanically). Most of the releases can operate with either direct or alternating current.

Power supply (Un)	24 V DC
	30 V AC/DC
	48 V AC/DC
	60 V AC/DC
	110-120 V AC/DC
	120-127 V AC/DC
	220-240 V AC/DC
	240-250 V AC/DC
	380-400 V AC
	440 V AC
Operating limits: (CEI EN 60947-2 Standards)	(YO-YO2): 70% ... 110% Un (YC): 85% ... 110% Un

Circuit-breaker opening takes place with power supply voltage values of the release equivalent to 35 - 70% Un.

Circuit-breaker closing is possible with power supply voltage of the release equivalent to 85-110% Un.

It can be fitted with a signalling contact for undervoltage release energized (C. aux YU).

Reference figures in the electrical circuit diagram: YU (6)

Inrush power consumption (Ps):	DC = 200 W
	AC = 200 VA
Continuous power (Pc):	DC = 5 W
	AC = 5 VA
Opening time (YU):	30 ms
Insulation voltage	2500V 50 Hz (for 1 min.)

Model	L2234		Apparatus	Emax	Scale
			Doc.No.	1SDH000460R0002	Page No. 24/155

Time delay device for undervoltage release (D)

The undervoltage release can be combined with an electronic time-delay device for installing outside the circuit-breaker, which enables a delay in the tripping of the release with preset, adjustable times. The use of the delayed undervoltage release is recommended when the power supply network of the release can be subject to power cuts or short-lived voltage drops, in order to avoid trips.

When it is not supplied, circuit-breaker closing is prevented.

The time-delay device has to be combined with an undervoltage release with the same voltage as the time-delay device.

Reference figures in the electrical circuit diagrams: YU + D;(7)

The characteristics of the time-delay device are:

Power supply (D):	24-30 V AC/DC
	48 V AC/DC
	60 V AC/DC
	110-127 V AC/DC
	220-250 V AC/DC
Adjustable opening time (YU+D):	0,5-1-1,5-2-3 s

Geared motor for automatic closing spring loading (M)

This automatically loads the circuit-breaker operating mechanism closing springs. After circuit-breaker closing, the geared motor immediately sees to reloading the closing springs.

When there is no power supply or during maintenance work, the closing springs can still be loaded manually (by means of the special lever on the operating mechanism).

Power supply	24-30 V AC/DC
	48-60 V AC/DC
	100-130 V AC/DC
	220-250 V AC/DC
Operating limits:	85...110% Un(CEIEN 60947-Standards)
Inrush power consumption (Ps):	DC = 500 W
	AC = 500 VA
Rated power (Pn):	DC = 200 W
	AC = 200 VA
Inrush time	0,2 s
Loading time:	4-5 s
Insulation voltage	2500V 50 Hz (for 1 min.)

It is always supplied with limit contacts and microswitch for signalling closing springs loaded.

Reference figure in the electrical circuit diagrams: M (1)

Model	L2234		Apparatus	Emax	Scale
			Doc. No.	1SDH000460R0002	Page No. 25/155

Mechanical and electrical trip signalling for overcurrent releases

The following signals are available following tripping of the overcurrent release:

a) Mechanical trip signalling for overcurrent releases

This enables a visual signalling on the operating mechanism by pushing the trip pushbutton in when the circuit-breaker has been opened following tripping of an overcurrent release. The circuit-breaker can only be closed again by putting the pushbutton back into its normal position included in the standard configuration.

Reference figure in the electrical circuit diagram: S51 (13).

b) Electrical and mechanical trip signalling for overcurrent releases

This enables a visual signalling on the operating mechanism (mechanical) and remotely (electrically by means of a changeover switch) of the circuit-breaker being opened following a trip of the overcurrent releases. To reset the circuit-breaker, it is necessary to reset the mechanical indicator pushbutton.

Reference figure in the electrical circuit diagram: S51 (13).

c) Coil for resetting the mechanical release trip indicator

This enables a visual signalling on the operating mechanism (mechanical) and remotely (electrically by means of a changeover switch) of the circuit-breaker being opened following a trip of the overcurrent releases. With this accessory, you can reset the mechanical indicator with an electronic relay using a remote control and this enables the circuit-breaker to be reset.

Power supply:	24-30 V AC/DC
	220-240 V AC/DC
	110-130 V AC/DC

Reference figure in the electrical circuit diagrams: S51 (14)

Auxiliary contacts

Auxiliary contacts installed on the circuit-breaker are available to enable an indication of the circuit-breaker's status. A special version of the auxiliary contacts is also available (gold plated contacts) for a rated voltage under 24 V (digital signal).

Un	In max	T
125 V DC	0.3 A	10 ms
250 V DC	0.15 A	10 ms

Un	In max	cosφ
250 V AC	5 A	0.3

The versions available are:

a) Electrical signalling for circuit-breaker open/closed

It is possible to have electrical signalling of the circuit-breaker status (open/closed) 4, 10 or 15 auxiliary contacts.

The auxiliary contacts can have the following configurations:

- 4 break/make contacts for PR121 (2 normally open + 2 normally closed)
- 4 break/make contacts for PR122/ PR123 (2 normally open + 2 normally closed + 2 for the release)
- 10 break/make contacts for PR121 (5 normally open + 5 normally closed);
- 10 break/make contacts for PR122/ PR123 (5 normally open + 5 normally closed + 2 for the release)
- 15 supplementary break/make contacts which can be mounted outside the circuit-breaker.

The basic configuration described above can be modified by the user to indicate normally open or normally closed by repositioning the rapid connector on the microswitch. When 10 contacts for PR122/ PR123 are required, zone selectivity and the PR120/K module are not available. Reference Fig. in the electrical circuit diagrams: Q/1 ÷ 10 (21-22)

b) Electrical signalling for circuit-breaker connected/test isolated/disconnected

In addition to mechanical signalling of the position of the circuit-breaker, it is possible to have electrical signalling by means of 5 or 10 auxiliary contacts which are installed on the fixed part.

Only available for circuit-breakers in withdrawable versions for installing on the fixed part.

The auxiliary contacts can have the following configurations:

Reference figure in the electrical circuit diagrams: S75I (31-32) - S75T (31-32) - S75E (31-32)

- 5 contacts; group consisting of 2 connected signalling contacts, 2 disconnected signalling contacts and 1 test position signalling contact (main contacts isolated, but sliding contacts connected)
- 10 contacts; group consisting of 4 connected signalling contacts, 4 disconnected signalling contacts and 2 test position signalling contacts (main contacts isolated, but sliding contacts connected).

c) Contact for signalling closing springs loaded

This consists of a microswitch which allows remote signalling of the state of the circuit-breaker operating mechanism closing springs. The contact is always supplied with the spring loading geared motor.

Reference figure in the electrical circuit diagrams: S33 M/2 - (11)

d) Contact for signalling undervoltage release energized (C.aux YU)

The undervoltage releases can be fitted with a contact (by choice, preferably closed or open) for signalling undervoltage energized for remote signalling of the state of the undervoltage release.

Reference figure in the electrical circuit diagrams: (12)

Transformers and operation counters

a) Current sensor for the neutral conductor outside the circuit-breaker

The sensor allows neutral protection by means of connection to the overcurrent release and is available only for three-pole circuit-breakers. It is supplied on request.

Reference figure in the electrical circuit diagram: UI/N

Model	L2234			Apparatus	Emax	Scale
				Doc.No.	1SDH000460R0002	Page No. 26/155

b) Homopolar toroid for the main power supply earthing conductor (star center of the transformer)

PR122 and PR123 microprocessor-based electronic releases may be used in combination with an external toroid located on the conductor, which connects the star center of the MV/LV transformer (homopolar transformer) to earth: in this case, the earth protection is defined as Source Ground Return.

The In of the toroid can be regulated to 100 A, 250 A, 400 A, 800 A by using different combinations of the connections. Reference figure in the electrical circuit diagrams: UI/0.

c) Homopolar toroid for residual current protection

The toroid enables the residual current protection to be activated and can be combined with the PR122/P LSIRc, PR122/P LSIG releases (with PR120/V) and PR123/P. The accessory is fitted with a dip-switch multiple selectors which is reset according to the required sensitivity (up to 3A or 30A) . The accessory is for installation on the busbars and is available in different sizes: up to 3200A for three- and four-pole circuit-breakers, up to 4000A for three-pole circuit-breakers.

d) Mechanical operations counter

This is connected to the operating mechanism by means of a simple lever mechanism. It indicates the number of circuit-breaker mechanical operations. The indication is visible on the front of the circuit-breaker from the outside.

10.2 Mechanical locks

a-b) Lock in open position

Different mechanisms are available which enable the circuit-breaker to be locked in the open position.

These devices can be controlled by:

- a key (a): a special circular lock with different keys (for a single circuit-breaker) or with the same keys (for several circuit-breakers). In the latter case, up to four different key code numbers are available.
- padlocks (b): up to 3 padlocks (not supplied): Ø 4 mm.

c) Circuit-breaker lock in connected - test isolated - disconnected position

This device can be controlled by a special circular lock with different keys (for a single circuit-breaker) or with the same keys (for several circuit-breakers available up to four different key code numbers) and by padlocks (up to 3 padlocks, not supplied - Ø 4 mm). Only available for circuit-breakers in withdrawable versions for installing on the moving part.

d) Accessories for lock in test isolated - disconnected position

In addition to the circuit-breaker lock in the connected - test isolated - disconnected position, this allows locking only in the disconnected or test isolated positions. Only available for circuit-breakers in withdrawable versions for installing on the moving part.

e) Accessories for shutter padlocks

They enable the shutters to be padlocked (installed on the fixed part) in the closed position. Only available for circuit-breakers in withdrawable versions for installing on the fixed part.

f) Mechanical lock on compartment door

This prevents the compartment door from being opened when the circuit-breaker is closed (and connected in the case of withdrawable circuit-breakers) and prevents circuit-breaker closing with the compartment door open.

Transparent protection covers

a) Protection covers for opening and closing pushbuttons

These protection covers, applied over the opening and closing pushbuttons, prevent the corresponding circuit-breaker operations except by using a special tool.

b) IP54 door protection

This is provided by means of a transparent plastic escutcheon plate which fully protects the front of the circuit-breaker and ensures a degree of protection to IP54. Mounted on hinges, it is fitted with a key lock.

Interlock between circuit-breakers

This mechanism makes the mechanical interlock between two or three circuit-breakers (even of different sizes and in any fixed/withdrawable version) by means of a flexible cable. The electrical circuit diagram for the electrical changeover by means of a relay (to be provided by the customer) is supplied with the mechanical interlock. The circuit-breakers can be installed vertically or horizontally.

4 types of interlocks are available:

- type A: between 2 circuit-breakers (power supply + emergency)
- type B: between 3 circuit-breakers (2 power supplies + emergency)
- type C: between 3 circuit-breakers (2 power supplies + bus-tie)
- type D: between 3 circuit-breakers (3 power supplies / a single closed circuit-breaker)

The emergency power supply is generally supplied in order to substitute the normal power supply in two cases.

- to supply safety services for people.
- to supply essential parts of the installation, other than the safety services.

The change over from the normal supply to the emergency supply, can be done manually (with a local or remote control) or automatically. For the change over, the circuit-breakers must be supplied with the necessary accessories for the electrical remote control and for electrical and mechanical interlocks provided for the changing over.

The accessories can be for example:

- the shunt opening release
- the shunt closing release
- the motor operator
- the auxiliary contacts.

Model	L2234			Apparatus	Emax	Scale
				Doc. No.	1SDH000460R0002	Page No. 27/155

For the change over, the customer can use a suitable electronic relay, whose diagram is supplied by ABB SACE. The mechanical interlocks between two or three circuit-breakers are made by means of cables that can be used for circuit-breakers installed, either side-by-side or one over the other.

Table of feasible mechanical interlocks between two or three circuit-breakers

Type of interlocks	Number of circuit-breakers	Type of circuit-breaker	Possible interlocks
A	TWO	a normal power supply unit and an emergency unit	the first circuit-breaker can be closed only if the second (emergency) breaker is open
B	THREE	a normal power supply unit and an emergency unit	the first and third circuit-breakers can be closed only if the second (emergency) breaker is open. The latter can be closed only if the first and third are open.
C	THREE	a unit of 2 supplies and a bus-tie. The two half-busbars can be supplied by a single transformer (bus-tie closed) or simultaneously by both (bus-tie open)	one or two circuit-breakers out of three can be closed at the same time
D	THREE	a unit of 3 supplies / a single closed circuit-breaker. Three supplies (generators or transformers) on the same busbar for which parallel operation is not allowed	only one of the three circuit-breakers can be closed

10.3 Spare parts and retrofitting

Spare parts

The spare parts available are:

- Shields and front escutcheon plate
- Opening solenoid for the PR121 / PR122 / PR123 overcurrent release
- Arcing chamber
- Closing springs
- Jaw-type isolating contact for fixed part of the withdrawable circuit-breaker
- Sliding earth contact (for withdrawable version)
- Fixed part shutters
- Complete pole
- Operating mechanism
- Current sensor and connection cables with the release
- Transparent protection for SACE PR 030/B power supply unit
- Tool case
- Front escutcheon plate for Ronis-type key lock

For further details, ask for the ABB SACE spare parts catalogue.

Retrofitting kit

The kits enable SACE Otomax and Novomax G30 circuit-breakers to be replaced, coupling the new circuit-breaker in the old switchboard.

Model	L2234			Apparatus	Emax	Scale
				Doc.No.	1SDH000460R0002	Page No. 28/155

11. Protection releases - General notes

Emax, the range of ABB air circuit breakers, now has a new range of electronic relays.

These are called PR121, PR122 and PR123, and they substitute the previous range PR111, PR112 and PR113.

The new protection releases integrate all the functions of their predecessors, adding new and interesting technical features that are useful for satisfying every current and future system installation need.

Every operational requirement is now met thanks to the different performance levels of the new relays and of the additional modules that can be fitted inside them (PR120/V, PR120/K, PR120/D-M, PR120/D-BT).

A table can best illustrate the technical features and the mix and matchability of the three relays.

Function/Unit	PR121	PR122	PR123
Current protections (L, S, I, G)	S	S	S
Additional protections (U, OT)	-	S	S
Voltage protections (D, UV, OV, RV, RP, UF, OF)	-	S ⁽⁴⁾	S
Harmonics analysis	-	-	S
Temperature protection	-	S	S
Local bus for separate auxiliary units	S	S	S
Serial wire communication (RS485)	-	S ⁽³⁾	S ⁽³⁾
Radio communication (wireless Bluetooth)	S ⁽¹⁾	S ^(1,2)	S ^(1,2)
Data Logger	-	S	S
Compatibility with SD.Pocket	S	S	S
Compatibility with SD.Testbus	S	S	S
Compatibility with PR010/T	S	S	S
PR120/V Measuring (internal voltages module)	-	O	S
PR120/K Signalling (internal signalling module)	-	O	O
PR120/D-M Com (internal communication module)	-	O	O
PR120/D-BT WL-Com (internal Bluetooth communication module)	-	O	O
PR021/K (separate signalling unit)	O	O	O
HMI030 (separate graphics interface)	O	O	O
PR030/B (separate power supply unit)	O	S	S
BT030 (separate Bluetooth communication unit)	O	O	O

Key:

- S** : standard function/unit,
O : optional function/unit,
 - : function/unit unavailable.

Notes:

1. : with separate BT030 unit (for temporary connections),
2. : with internal PR120/D-BT module,
3. : with PR120/D-M module,
4. : with PR120/V module.

The main features and improvements of the new relay PR12x with respect to the earlier PR11x are (depending on the combination of relay-modules):

1. High current reading accuracy (1.5%) and numerous other functions.
2. The PR120/V module for measuring line voltages up to 690 V, is integrated in the relay, making a separate voltage transformer unnecessary.
3. Double settings for the protection functions (PR123/P).
4. Input can be combined with actions selectable by the user (with PR120/K).
5. Four power outputs fully-configurable by the customer in terms of status, delay and type (with PR120/K).
6. Wireless Bluetooth connection to PDA and/or PC (with PR120/D-BT).
7. Freely available software for relay testing and maintenance.
8. High-performance data logger with 8 analogue signals and 4 digital signals, which can be synchronized with hundreds of events/situations of the user's choice.
9. Relay powered even with the circuit-breaker open, using the busbar voltages (with PR120/V).
10. New residual-current function (Rc).
11. Double protection G function, with simultaneous reading from two sensors (PR123).
12. Continuous control of the connection of the current sensors and trip coil (all relays).
13. Analysis up to the 40th harmonic.
14. Cause of trip is memorized even in self-powered mode (all relays).
15. PR121 with serial link for separate PR021/K and HMI030 module.
16. Extended neutral selection.
17. Double protection S (PR123).
18. Date and time in "real time" (all relays).

Model	L2234			Apparatus	Emax	Scale
				Doc. No.	1SDH000460R0002	Page No. 29/155

11.1 Safety notes

 **WARNING:** this symbol gives information about operations, actions or circumstances that can cause injuries to the personnel, damage to the unit or economic losses.

Read this manual carefully and completely.
The use of this device should be reserved for qualified and expert personnel only.

If in doubt, about its safe usage, the unit must be put out of service to prevent any accidental use.

You must assume that safe usage is impossible if:

1. the unit shows visible signs of damage.
2. the unit does not function (for example with autotest or with the trip test unit).
3. the unit has been damaged in transit.

11.1.1 Notes for dielectric stiffness tests

 **Dielectric stiffness tests on the releases, inputs and outputs, are not permitted.**

11.2 Abbreviations and notes

11.2.1 Abbreviations

BA	Opening coil
BC	Closing coil
CB	Circuit Breaker (for example Emax)
BT030	Wireless communication unit
CS	Current Sensor (current transformer)
PDA	Pocket Pc with Bluetooth
Emax	Series of ABB SACE air circuit-breakers
HMI030	Human Machine Interface
HW	Hardware
In	Rated current of the Rating Plug installed in the circuit-breaker
MT	Thermal memory
Pn	Circuit-breaker rated power
Pn _{phase}	Phase rated power
PR120/K	Internal signalling unit of alarms and trips on the circuit-breaker
PR120/V	Measuring module
PR021/K	Signalling unit
PR120/D-M	Communication module
PR120/D-BT	Wireless communication module
BT030	Wireless communication unit
PR010/T	ABB SACE unit test
PR121/P	Protection relay for CB Emax
PR122/P	Protection relay for CB Emax
PR123/P	Protection relay for CB Emax
PR030/B	ABB SACE power supply unit
Relay	also called "protection unit" or "protection release"
RMS	Root mean square value
TC	Trip Coil (opening solenoid)
SdZ	Zone selectivity
SGR	External toroid
SW	Software
i Test	"i Test" button on the front of relay
Trip	CB opening, generated by the release
VT	Voltage transformer (see also VS)
Un	Rated voltage of the voltage transformers installed (phase voltage)
Vaux	Auxiliary power supply
VS	Voltage Sensor (see also VT)

11.2.2 Notes

- A. Use the "Belden 3105A"- type two-wire cable for instance (not supplied by ABB SACE).
- B. Use the "Belden 3106A"- type three-wire cable for instance (not supplied by ABB SACE).
- C. The unit has a "backup-protection" function; if the first command to the opening solenoid does not open immediately the circuit-breaker (TC partially fault), TRIP commands are repeatedly sent until the circuit-breaker opens (providing a Vaux is present) or the current disappears (if self-power supplied). The "backup" condition can be signalled by configuring the unit relays; using the "YO back" selection, it is possible to command the "opening coil(YO)" accessory as another opening device if TC does not work.

Model	L2234			Apparatus	Emax	Scale
				Doc.No.	1SDH000460R0002	Page No. 30/155

12. SACE PR121/P Release - Identification

The PR121/P units available, in accordance with the IEC Standards, with the various default and optional protections and modules, are illustrated in the figure below.

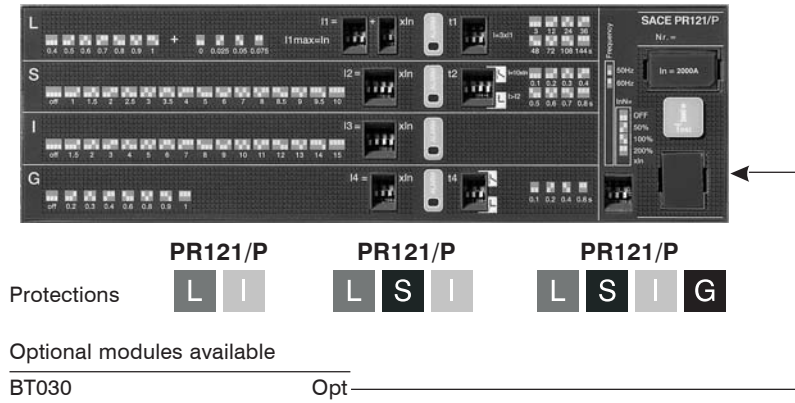

12.1 Standard

The PR121/P has been designed to work in accordance with the following international standard:
IEC 60947-2 Low voltage apparatus. Circuit-breakers.

12.2 Specifications

12.2.1 General

The PR121/P unit is a high-performance self-supplied protection unit with **Protection** functions for the ABB SACE 'Emax' range of 3-pole and 4-pole low voltage air circuit-breakers. The unit's user interface also enables parameter setup and complete pre-alarm and alarm management with LED warning/alarm indicators for the protection and watchdog functions.

Depending on the version, the protections available are as follows:

Symbol	Protection against
L	overload with inverse long time delay
S	short-circuit with adjustable delay
I	instantaneous short-circuit
G	earth fault with adjustable delay

The PR121/P can be installed on 3-pole CBs with and without an external neutral, or on 4-pole CBs.

It should be noted that the reference current for the PR121/P is the I_n (the rated current defined by the Rating Plug) and not the I_u (the uninterrupted rated current of the CB itself).

Example: the CB E1B800 with a 400A Rating Plug has an I_u of 800A and an I_n of 400A.

The unit opens the circuit breaker in which it is installed by means of the TC, which takes effect directly on the device's mechanical leverism.

The unit is made using digital microprocessor technology and interfaces with the user by means of DIP switches. The unit's protection parameters and general operating mode can be set entirely by the user.

12.2.2 Electrical characteristics

Rated operating frequency	50/60 Hz \pm 10%
Pass band	3000 Hz max
Peak factor	6.3 max @ 2 In
MTBF (MIL-HDBK-217E)	15 years @ 45°C

12.2.2.1 Self-supply

The unit requires no outside power source for the protection and alarm signal functions. It is self-supplied by the current sensors installed on the circuit breaker. For it to function, it simply needs the current defined below to be flowing in at least one phase. An outside power source can, however, be connected to enable other functions and particularly for its connection to the separate devices: HMI030 and PR021/K.

The characteristics of the busbar current are given in the table below:

Characteristics	E1 - E2 - E3	E4 - E6
Single-phase minimum busbar current for enabling relay	70 A	140 A

12.2.2.2 Auxiliary power supply

The outside auxiliary power supply is provided using a galvanically-separated power pack.



Since the auxiliary voltage needs to be isolated from the ground, "galvanically separated converters" in accordance with the IEC standard 60950 (UL 1950) or the equivalent IEC 60364-41 and CEI 64-8 have to be used to guarantee a current in common mode or leakage current (as defined in IEC 478/1 and CEI 22/3) no greater than 3.5 mA.

Model	L2234	Apparatus	Emax	Scale
		Doc.No.	1SDH000460R0002	Page No. 31/155

The presence of the auxiliary power supply enables the relay unit to be used even with the circuit breaker open. The characteristics of the power pack are given in the table below.

Characteristics	Version PR121/P
Auxiliary voltage (galvanically separated)	24V DC $\pm 20\%$
Maximum ripple	5%
Inrush current @ 24 V	$\sim 10A$ for 5ms
Rated power @ 24 V	$\sim 2W$

12.2.3 Environmental characteristics

Operating temperature	-25°C ... +70°C
Storage temperature	-40°C ... +90°C
Relative humidity	0% ... 98% with condensation
Degree of protection (with PR121/P installed in the circuit-breaker)	IP 30

12.2.4 Communication bus

Local internal bus on rear connector; RS485 physical interface, ABB SACE protocol.

12.2.5 Protection functions

The PR121/P unit provides 5 independent protection functions, i.e.:

1. protection against overload with inverse time "L";
2. protection against short-circuit with adjustable delay "S";
3. protection against instantaneous short-circuit "I";
4. protection against earth fault with adjustable delay "G";
5. protection against instantaneous short circuit at high currents "Inst".

The PR121/P unit allows the neutral pole's current signal to be processed using different relationships with the value of the phases.

N.B.: Beyond 15.5xIn of current on the Ne, the protection is considered as being set to 100%.

A timing indication ("alarm" LED) is provided on the front of the unit, which is enabled during an alarm for each protection; it is disabled when the alarm condition ceases or when the protection has been tripped.

The unit also has a "backup protection" function. If the circuit breaker does not open immediately the first time the Trip Coil is hit (partial TC failure), TRIP commands are sent repeatedly until the circuit breaker opens.

For the inverse-time protections, the relationship between trip time and overcurrent is given by the formula: $t=k/I^2$.

For the fixed-time protections with an adjustable delay, the relationship adopted is as follows: $t=k$.

12.2.5.1 Calculating the RMS and Peak

All the protection functions do their respective processing on the basis of the real rms value of the currents (the protection G is disabled for current values greater than $8 I_n$ [where $I_4 \geq 0.8 I_n$], greater than $6 I_n$ [where $0.5 I_n \leq I_4 < 0.8 I_n$] and greater than $4 I_n$ [where $I_4 < 0.5 I_n$]).

For currents higher than $6 x I_n$, and for the "I" function, processing takes into account the peak value divided by $\sqrt{2}$ (so the sinusoidal wave form is considered); this is due to incompatibility between the trip time and the rms value calculation time.

If the waveform has a deformation beyond the declared limit ($6.3 @ 2 I_n$), the tolerance for the calculation of the true rms value will increase.

12.2.5.2 Watchdog

The PR121/P unit provides some watchdog functions to guarantee the proper management of relay malfunctions. These functions are as follows:

- Rating PLUG validity
- Watchdog for proper current sensor connection (CS). Any anomalies are indicated by the LED coming on, as explained in par. 12.7.1.
- Watchdog for proper opening solenoid connection (TC). Any anomalies are indicated by the LED coming on, as explained in par. 12.7.1.
- Watchdog for protection against Hw Trip. If the sensors are disconnected or there is a Rating Plug error, a CB opening command is issued due to the TC being activated.

12.2.6 Description of the protection functions

12.2.6.1 Protection "L"

The "L" is the only protection that cannot be disabled because it is for self-protection against overloading of the relay itself.

The type of curve that can be set is $t=k/I^2$.

The inverse-time protection trip time is given by the expression

$$\max \left[\frac{9 \cdot t_1}{(I_f / I_1)^2}, 1 \right] \text{ where } I_f \leq 12 I_n, 1 \text{ s where } I_f > 12 I_n$$

I_f is the fault current and I_1 the protection threshold, established by the user.

NB: Time expressed in seconds.

12.2.6.2 Protection "S"

This protection can be disabled; it can be of the fixed time ($t=k$) or inverse time ($t=k/I^2$) type; in the latter case, the trip time is given by the expression

$$\max \left[\frac{100 \cdot t_2}{(I_f)^2}, t_2 \right] \text{ where } I_f > I_2$$

I_f is the fault current and I_2 the protection threshold, established by the user.

NB: Time expressed in seconds.

Model	L2234			Apparatus	Emax	Scale
				Doc.No.	1SDH000460R0002	Page No. 32/155

12.2.6.3 Protection "I"

This protection can be disabled; it is of the fixed time (t=k) type, and is designed for a nil intentional delay.

12.2.6.4 Protection "G"

This protection can be disabled; it can be of the fixed time (t=k) or inverse time (t=k/i²) type; in the latter case, the trip time is given by the expression:

$$\max \left[\frac{2}{i^2}, t_4 \right] \text{ where } I = I_f / I_4$$

I_f is the fault current and I₄ the protection threshold, established by the user.

NB: Time expressed in seconds.

The PR121/P unit can provide earth fault protection, achieved inside the relay by vectorially adding together the phase and neutral currents. The fault current is defined by the following formula:

$$\vec{I}_G = \vec{I}_1 + \vec{I}_2 + \vec{I}_3 + \vec{I}_N$$

If the circuit reveals no faults, the module of the sum of these currents is always nil; vice versa, the value of the fault current takes on a larger and larger value depending on the entity of the fault.

12.2.6.5 Protection against instantaneous short-circuit "Iinst"

This function has a single fixed-time protection curve.

When the protection is tripped, the circuit breaker is opened by the opening solenoid (TC).

12.2.7 Summary table of protections

Protection	Disabling	Trip threshold	Trip time	Trip threshold tolerance	Trip time tolerance
L (t=k/I ²)	<input type="checkbox"/>	I1 = 0.4 - 0.425 - 0.45 - 0.475 - 0.5 - 0.525 - 0.55 - 0.575 - 0.6 - 0.625 - 0.65 - 0.675 - 0.7 - 0.725 - 0.75 - 0.775 - 0.8 - 0.825 - 0.85 - 0.875 - 0.9 - 0.925 - 0.975 - 1 x In	t1 = 3 - 12 - 24 - 36 - 48 - 72 108 - 144 s ⁽¹⁾ @ 3 I1	Release between 1.05 and 1.2 x I1	± 10% I _f ≤ 6 x In ± 20% I _f > 6 x In
S (t=k)	<input checked="" type="checkbox"/>	I2 = 1 - 1.5 - 2 - 2.5 - 3 - 3.5 - 4 - 5 - 6 - 7 - 8 - 8.5 - 9 - 9.5 - 10 x In	where I > I2 t2 = 0.1 - 0.2 - 0.3 - 0.4 - 0.5 - 0.6 0.7 - 0.8 s	± 7% I _f ≤ 6 x In ± 10% I _f > 6 x In	The best of the two data: ± 10% or ± 40 ms
S (t=k/I ²)	<input checked="" type="checkbox"/>	I2 = 1 - 1.5 - 2 - 2.5 - 3 - 3.5 - 4 - 5 - 6 - 7 - 8 - 8.5 - 9 - 9.5 - 10 x In	t2 = 0.1 - 0.2 - 0.3 - 0.4 - 0.5 - 0.6 0.7 - 0.8 s @ 10 In	± 7% I _f ≤ 6 x In ± 10% I _f > 6 x In	± 15% I _f ≤ 6 x In ± 20% I _f > 6 x In
I (t=k)	<input checked="" type="checkbox"/>	I3 = 1.5 - 2 - 3 - 4 - 5 - 6 - 7 - 8 - 9 - 10 - 11 - 12 - 13 - 14 - 15 x In	≤ 30 ms	± 10%	
G (t=k)	<input checked="" type="checkbox"/>	I4 = 0.2 - 0.3 - 0.4 - 0.6 - 0.8 - 0.9 - 1 x In	where I > I4 t4 = 0.1 - 0.2 - 0.4 - 0.8 s	± 7%	The best of the two data: ± 10% or ± 40 ms
G (t=k/I ²)	<input checked="" type="checkbox"/>	I4 = 0.2 - 0.3 - 0.4 - 0.6 - 0.8 - 0.9 - 1 x In	t4 = 0.1 - 0.2 - 0.4 - 0.8 s @ 4 I4	± 7%	± 15%
I inst	<input type="checkbox"/>	Automatic, defined by SACE	Instantaneous	± 5%	+1 ms

⁽¹⁾ The minimum value of this trip is 1s regardless of the type of curve set (self-protection).

⁽²⁾ These tolerances apply in the following conditions:
- self-powered relay at full power (without start-up)
- two-phase or three-phase power supply
- trip time setting ≥ 100ms

For all cases not covered by the above hypotheses, the following tolerances apply:

Protections	Trip threshold	Trip time
L	Release between 1.05 and 1.25 x I1	± 20%
S	± 10%	± 20%
I	± 15%	≤ 60ms
G	± 10%	± 20%
Others	± 20%	

12.2.8 Measurements

The PR121/P protection unit can take the various types of measurement shown in the following table with the corresponding tolerances.

Type of measurement	Range	Tolerance %
Phase and neutral current	0.3 ... 6 In	1.5
Earth fault current	0.3 ... 4 In	1.5

Model	L2234		Apparatus	Emax	Scale
			Doc.No.	1SDH000460R002	Page No. 33/155

12.2.9 Trip curves

The trip curves provided are merely for guidance and only show a sub-group of the possible selections (see par. 12.2.7).

12.2.9.1 Trip curves for functions L-I

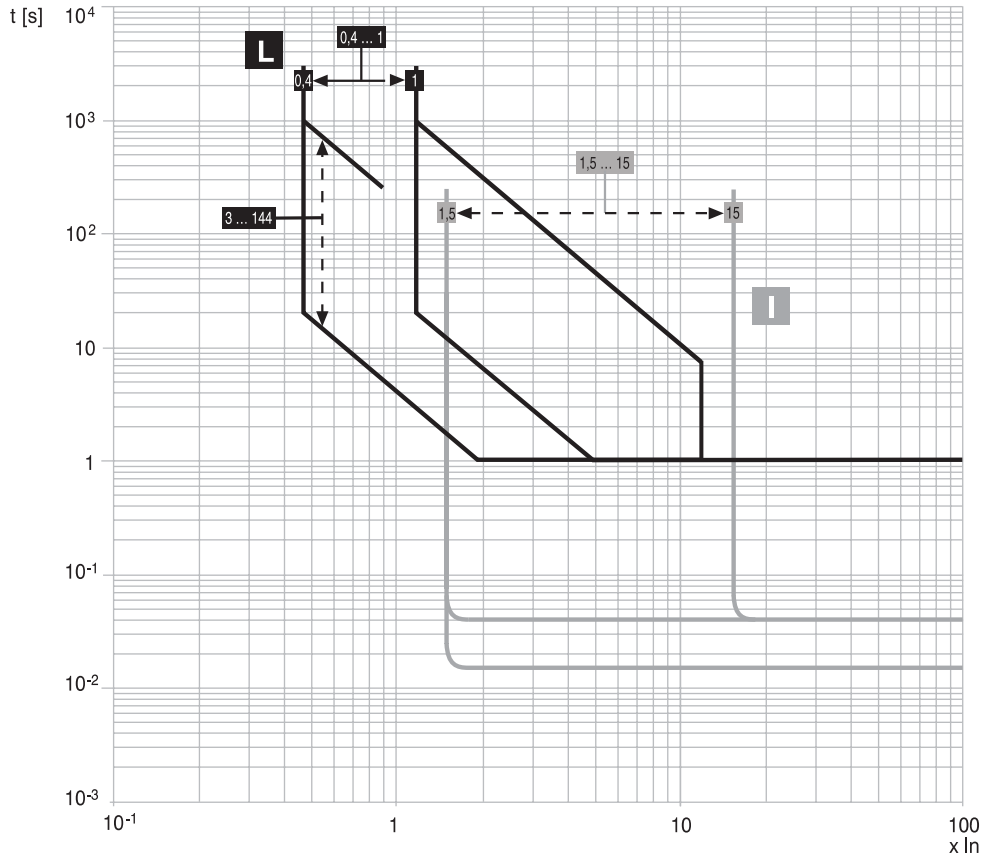

12.2.9.2 Trip curves for functions L-S(t = k/I²)-I

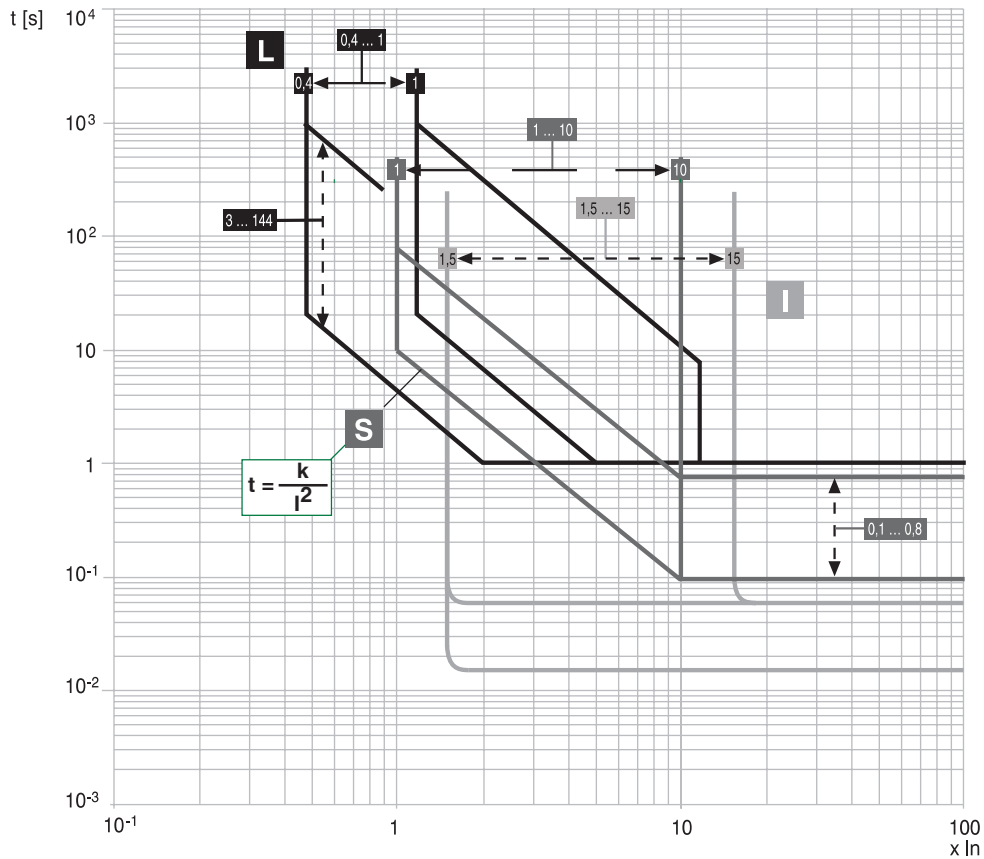

Model	L2234		Apparatus	Emax	Scale
			Doc.No.	1SDH000460R0002	Page No. 34/155

12.2.9.3 Trip curves for functions L-S(t=k)-I

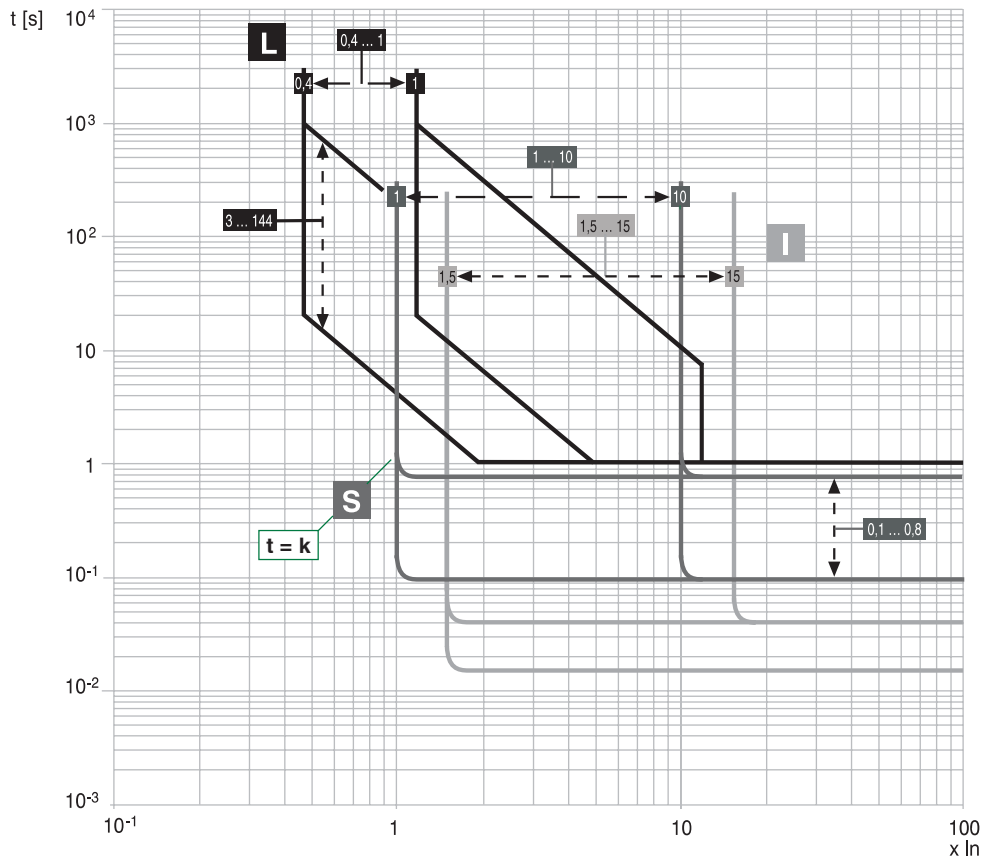

12.2.9.4 Trip curves for function G

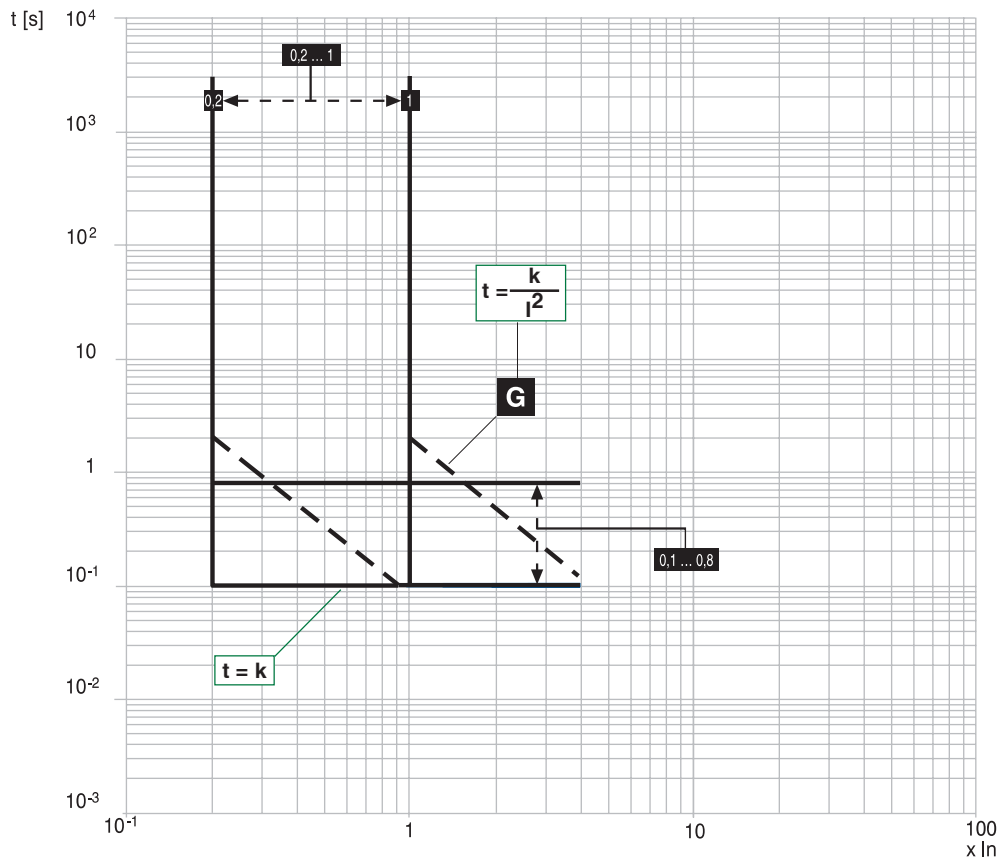

Model	L2234		Apparatus	Emax	Scale
			Doc.No.	1SDH000460R002	Page No. 35/155

12.3 Other functions

12.3.1 Indication of the cause of the trip and trip test button

Using the "i Test" button, you can retrieve the information stored in the past 48 hours. You can also perform a trip test by pressing and holding the button for 7 seconds with Vaux and/or a current to the phases, and an Autotest by pressing and holding the button for 3 seconds, again with the PR030/B battery unit connected.

12.4 Putting into service

12.4.1 Connections



For the connections provided by the user, it is recommended that you comply strictly with the recommendations contained in this document.

This will enable us to satisfy all the international reference standards and guarantee the perfect operation of the relay even under severe environmental and electromagnetic conditions. Take particular care with the earthing connections.

12.4.2 CS and TC connection check



If the PR121/P has been installed by the user, it is advisable (with the CB open and Vaux or the PR030/B) to check the proper connection of the TC and/or CS cables before putting the circuit breaker into service; if this has not been done, make the right connections. If any of the red LEDs come on, this means an error in the connection of the CS and/or TC. See par. 12.7.1.

12.4.3 Current sensor connection for external neutral



If you want to connect the current sensor for the external neutral conductor to a three-pole circuit breaker, remember to set InN accordingly (see par 12.5, ref. 14)

During this procedure, the circuit breaker must be open and preferably isolated.

12.5 User interface

Captions on the front of the PR121/P unit:

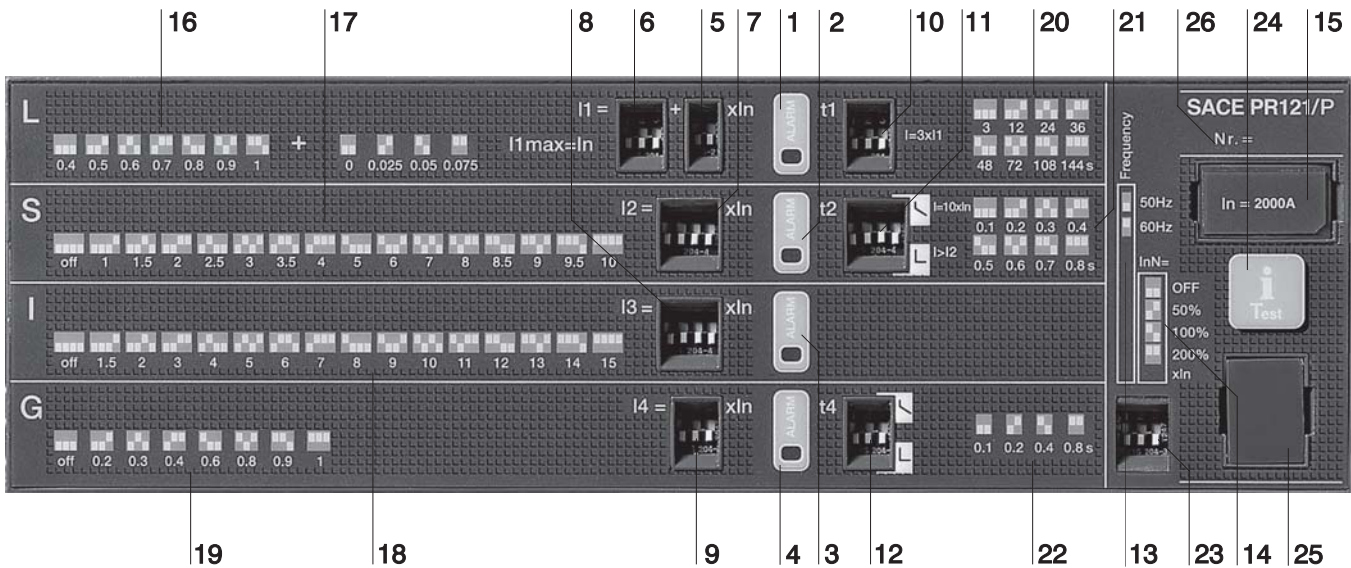

Ref.	Description
1	Alarm indicator LED for protection function L
2	Alarm indicator LED for protection function S
3	Alarm indicator LED for protection function I
4	Alarm indicator LED for protection function G
5	DIP switch for fine-setting of current threshold I1
6	DIP switch for the main setting of the current threshold I1
7	DIP switch for setting current threshold I2
8	DIP switch for setting current threshold I3
9	DIP switch for setting current threshold I4
10	DIP switch for setting trip time t1
11	DIP switch for setting trip time t2 and type of curve

Model	L2234	Apparatus	Emax	Scale
		Doc.No.	1SDH000460R0002	Page No. 36/155

Ref.	Description
12	DIP switch for setting trip time t4 and type of curve
13	Position indicator for the DIP switches for the mains frequency
14	Position indicator for the DIP switches for setting the neutral protection
15	Rating plug
16	Position indicator for the DIP switches for setting the threshold I1
17	Position indicator for the DIP switches for setting the threshold I2
18	Position indicator for the DIP switches for setting the threshold I3
19	Position indicator for the DIP switches for setting the threshold I4
20	Position indicator for the DIP switches for setting the time t1
21	Position indicator for the DIP switches for setting the time t2
22	Position indicator for the DIP switches for setting the time t4
23	DIP switch for setting the mains frequency and adjusting the neutral protection
24	"i Test" test and info button
25	Test connector for connecting or testing the release using an external device (PR030/B battery unit, BT030 wireless communication unit and SACE PR010/T unit)
26	Serial number of the PR121/P protection release

12.5.1 Trip Test

Before you start, it is advisable to run a test ("Trip Test") on the whole TC chain by pressing and holding the button "i Test" for at least 7 s. A positive outcome is shown by the circuit-breaker opening (see Watchdog). To be able to do the test, you need to connect the PR030/B battery unit.

12.5.2 Initial settings

ABB SACE will see to applying the adhesive labels on the PR121/P for all the variables relating to the circuit breaker (e.g. Type of circuit breaker, Rating Plug size, etc.)

It should be noted that ABB SACE provides a sensible definition for each possible setting (see par. 12.5.4).



Before putting the PR121/P into service, it is nonetheless absolutely essential for the user to carefully define each parameter that can be changed.

12.5.3 Changing protection functions

This paragraph enables the user to set the protection functions implemented in the PR121/P unit. Only the setting methods and which values can be selected are explained here. For all other information on the technical characteristics of the protection functions, see par.12.2.5.



No parameter settings can be made if the PR121/P unit is in alarm conditions.

12.5.3.1 Example of setting

In the diagrams on the front plate (see par. 12.5) relating to the settings, the position of the DIP switch is indicated by the white part.

An example of how to set the DIP switch for the protection function L is given below, where $I_n = 2000A$:

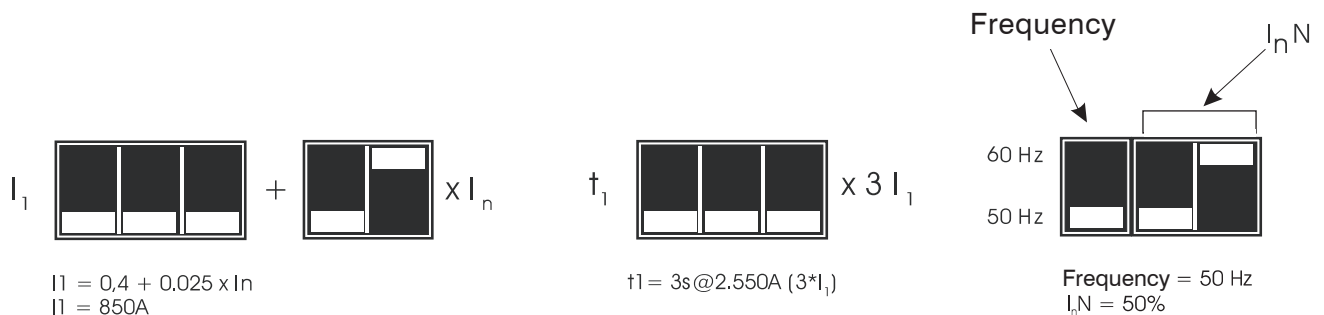

A faulty configuration of the dip-switches generates a configuration error which is signalled by means of a LED (see par.12.7.1).

Model	L2234		Apparatus	Emax	Scale
			Doc.No.	1SDH000460R0002	Page No. 37/155

12.5.4 PR121/P default settings

The PR121/P is supplied by ABB SACE with the following preset parameters:

#	Protection	Thresholds Time	
1	L	1 I _n	144 s
2	S	Off	0.1 s
3	I	4 I _n	–
4	G	Off	0.1 s
15	Net Frequency	50 Hz	
18	Neutral sel.	50 %	

12.6 Operating instructions / Operation in service

12.6.1 Adjusting the neutral

The neutral protection is normally set to a current value 50% of the adjustment made on the phases.

In some installations, where particularly high harmonics occur, the current circulating on the neutral may be higher than that of the phases.

In the SACE PR121/P release, this protection can be set for the following values: I_nN = 0 - 50% - 100% - 200% * I_n.

The table below shows the values that can be set adjusting the neutral in the various possible combinations between types of circuit-breaker and adjustment of the threshold I_n.



With three-pole circuit breakers, without external neutral sensor, the adjustment of the neutral must be set to OFF.

12.6.2 Table of neutral adjustments

Adjustments of the threshold I₁ (Protection L)

Circuit breaker size	I ₁ ≤ 0.5	I ₁ > 0.5
E1	50-100-200%	50-100%
E2	50-100-200%	50-100%
E3	50-100-200%	50-100%
E4	50-100%	50%
E4/f	50-100-200%	50-100%
E6	50-100%	50%
E6/f	50-100-200%	50-100%

Note 1: The I₁ = 1 I_n setting is intended as the maximum adjustment of the protection against overload. The actual maximum allowable adjustment must take into account any temperature derating, the terminals used and the altitude.



Failure to comply with the setting limits for "I₁" and "I_nN" can damage the circuit breaker, with consequent risks to the operator too.

The relay records any erroneous setting between I₁ and the neutral setting and signals this by means of a LED (see par. 12.7.1).

12.6.3 Replacing an electronic release

To complete the procedure for installing PR121/P take the following steps:

1. With the circuit breaker open and possibly disconnected, install the protection unit on the circuit breaker.
2. Power the unit with the PR030/B ONLY.
3. If there are no errors other than the configuration error (flashing orange LED), press and hold the "i Test" button for a few seconds until all the red LEDs start to flash to confirm that installation is complete.
4. Remove the PR030/B.
5. Power the relay from any supply (Vaux, PR030/B, PR010/T).
6. Make sure there are no configuration errors (all LEDs off).
7. Circuit breaker and release can now be put into service.

Model	L2234			Apparatus	Emax	Scale
				Doc.No.	1SDH000460R0002	Page No. 38/155

12.7 Definition of the alarms and signals for the PR121/P unit

12.7.1 Optical signals

The following table shows how the LEDs are managed in accordance with the IEC standard 60073 (and clause 4.2.3.2 in particular). The LED alerts you to the status of the function set on its zone; e.g. in the figure in par. 12.5 the LED referenced as 1 identifies the status of the function L.

Type of information	Flashing slowly (0.5Hz)	Flashing fast (2Hz)		LED flashing with two 0.5 sec pulses every 2 sec	LED flashing with one pulse every 3 sec		LED on permanently		
	All LEDs	All LEDs	Single LED	All LEDs	Single LED		All LEDs	Single LED	
	RED	RED	RED	RED	RED	ORANGE	RED	RED	ORANGE
TC error		<input checked="" type="checkbox"/>							
CS error	<input checked="" type="checkbox"/>								
Rating Plug error				<input checked="" type="checkbox"/>					
Protection timing alarm			<input checked="" type="checkbox"/>						
Last trip ⁽¹⁾								<input checked="" type="checkbox"/>	
Test button pressed and no failure detected ⁽²⁾							<input checked="" type="checkbox"/>		
L prealarm									<input checked="" type="checkbox"/>
Settings inconsistency			<input checked="" type="checkbox"/>						
Normal relay operation ⁽³⁾						<input checked="" type="checkbox"/>			
HW Trip ⁽⁴⁾									

(1) Information on the "Last trip" is displayed when the LED relating to the protection unit that has been tripped comes on. The LED remains on for 2 sec, or permanently if an outside power supply (from the PR030/B) is being used.

(2) The information is displayed with all the LEDs on for as long as the test button is pressed and held, or for 2 sec.

(3) If other signals aren't present, the unit's operating mode is indicated 3 sec after the unit has been turned on.

(4) Configuration or connection error.

12.7.2 Troubleshooting

The following table lists a series of typical service conditions, to help you understand and solve hypothetical faults or malfunctions.

N.B.:

- Before consulting the following table, check for a few seconds for any optical signals provided by the LEDs.
- FN indicates the normal operation of the PR121/P.
- If the following suggestions fail to solve the problem, please contact the ABB SACE customer support service.

N°	Situation	Possible causes	Suggestions
1	The trip test cannot be run	1. The busbar current is > 0. 2. The TC is not connected	1. FN 2. Check TC connection (see par.12.4.2)
2	Trip times lower than expected	1. Threshold too low 2. Curve too low 3. Incorrect neutral selection	1. Correct threshold 2. Correct curve 3. Correct neutral adjustment
3	Trip times higher than expected	1. Threshold too high 2. Curve too high 3. Curve type "t=k/I ² " 4. Incorrect neutral selection	1. Correct threshold 2. Correct curve 3. Select curve type "t=k" 4. Correct neutral adjustment
4	Rapid trip, with I3=Off	Inst tripped	FN short-circuit with high I
5	Earth fault current beyond threshold, but no trip occurs	G function automatically inhibited	FN
6	Expected trip does not happen	Function OFF	FN enable protection function if necessary

Model	L2234		Apparatus	Emax	Scale
			Doc.No.	1SDH000460R0002	Page No. 39/155

12.7.3 In the case of a fault



If the PR121/P is suspected of being faulty, there are signs of malfunctions or it has generated an unexpected trip, we advise you to strictly follow the recommendations below:

1. Press the "i Test" button (within 48 hours of opening the CB) and make a note of which LED is on, also recording the type of CB, the number of poles, any connected accessories, the In, and the serial number (see par. 12.5).
2. Prepare a brief description of the opening (when did it happen?, how many times?, was it always under the same conditions? what type of load? what current? is the event reproducible?)
3. Send/communicate all the information collected, together with the circuit diagram for the circuit-breaker, to your nearest ABB Customer Support service.

The more the information given to the ABB Customer Support service is complete and accurate, the easier the technical analysis on the problem encountered will be, enabling us to take all action to help the user without delay.

12.8 Accessories

12.8.1 ABB SACE PR010/T test and configuration unit

Testing with the SACE PR010/T unit enables you to monitor the proper operation of thresholds and trip times of the protection functions "L", "S", "I", and "G". The test unit is wired to the relay by a dedicated connector (see ref. 25 par.12.5).

12.8.2 BT030 communication unit

Using the BT030 wireless communication unit, the PR121/P can be connected by radio to a hand-held PC (PDA) or normal PC, thus extending the amount of information available to the user. In fact, using the SD-Pocket communication software by ABB SACE, you can read the values of the currents flowing through the circuit breaker, the value of the last 20 currents broken and the protection settings.

12.8.3 PR021/K and HMI030 units

The PR121/P can also be connected to the optional PR021/K external signalling unit (see par. 16), for the signalling by means of no-potential power contacts of alarms and tripped protections, and to the HMI030 unit to view various kinds of information on the display.

12.8.4 PR030/B power supply unit

The PR030/B power supply unit is a separate unit for powering the relay, auto test and trip test.

Model	L2234			Apparatus	Emax	Scale
				Doc.No.	1SDH000460R0002	Page No. 40/155

13. SACE PR122/P Release - Identification

The PR122/P units available, in accordance with the IEC standards, together with the various protections and the various standard and optional modules, are illustrated in the following figure.

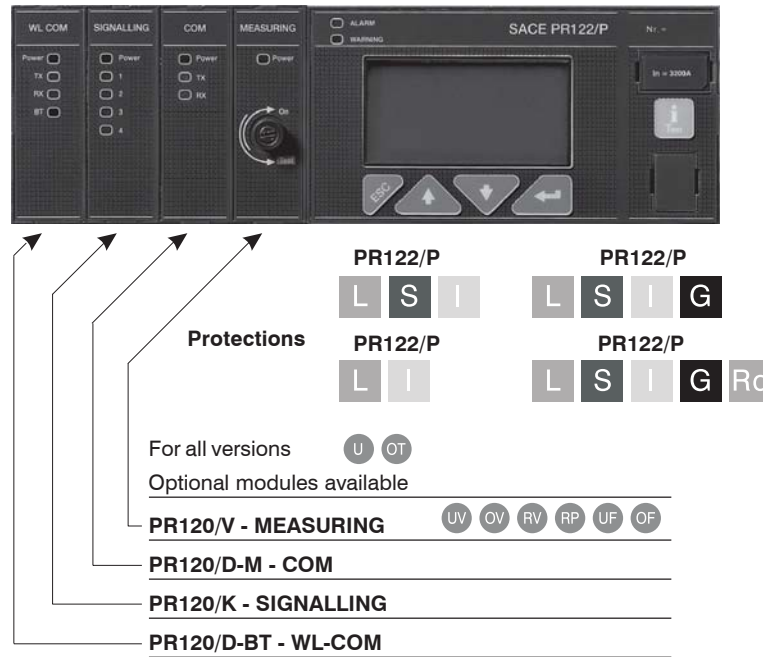

13.1 Standard

The PR122/P has been designed to work in accordance with the international standard: **IEC 60947-2 Low voltage apparatus. Circuit-breakers.**

13.2 Specifications

13.2.1 General

The PR122/P is a high-performance self-supplied protection unit with **Protection, Measurement, Data storage, Communication (optional), Self-test, Load control and Zone selectivity** functions for the ABB SACE 'Emax' range of 3- and 4-pole low-voltage air circuit breakers. The unit's user interface also enables parameter setup and complete the prealarm and alarm management for the protection and watchdog functions.

The protections available are:

Symbol	Protection against
L	overload with inverse long time delay
S	short-circuit with adjustable delay
I	instantaneous short-circuit
G	earth fault with adjustable delay
U	phase unbalance
OT	temperature out of range

The PR122/P can be installed on 3-pole CBs with and without an external neutral, or on 4-pole CBs.

It should be noted that the reference current for the PR122/P is the I_n (the rated current defined by the front Rating Plug) and not the I_u (the uninterrupted rated current of the CB itself). Example: the CB E1B800 with a 400A Rating Plug has an I_u of 800A and an I_n of 400A.

The unit opens the circuit breaker in which it is installed by means of the TC, which takes effect directly on the device's mechanical leverism. The protection unit is self-supplied by current sensors and primary voltages if the PR120/V module is installed. The unit is made using digital microprocessor technology and interfaces with the user by means of a graphic display and keyboard.

With the optional PR120/V module, the PR122/P also assures the following protections:

Symbol	Protection against
UV	undervoltage
OV	overvoltage
RV	residual voltage
RP	reverse active power
UF	underfrequency
OF	overfrequency

Model	L2234	Apparatus	Emax	Scale
		Doc.No.	1SDH000460R0002	Page No. 41/155

13.2.2 Electrical characteristics

Rated operating frequency	50/60 Hz ±10%
Pass band	3000 Hz max
Peak factor	6.3 max @ 2 In
MTBF (MIL-HDBK-217E)	15 years @ 45°C

13.2.2.1 Self-supply

The self-supply enables the protection unit to be powered with the busbar current using current transformers. Using this supply mode, the unit's protection functions are assured, however, not the accessory functions regarding the modules. The characteristics are given in the table below:

General characteristics	E1 - E2 - E3	E4 - E6
Minimum single-phase busbar current for enabling relay	70 A	140 A

13.2.2.2 Auxiliary power supply

The external auxiliary power supply is provided using a galvanically-separated power pack.



Since the auxiliary voltage needs to be isolated from the ground, "galvanically separated converters" in accordance with the IEC standard 60950 (UL 1950) or the equivalent IEC 60364-41 and CEI 64-8 have to be used to guarantee a current in common mode or leakage current (as defined in IEC 478/1 and CEI 22/3) no greater than 3.5mA.

The presence of the auxiliary power supply enables the relay unit to be used even with the circuit breaker open, as well as powering all the modules, with the exception of the PR120/V module, which is powered by means of a connection to the busbars. The characteristics of the power pack are given in the table below:

Characteristics	Version PR122/P
Auxiliary voltage (galvanically separated)	24V DC ±20%
Maximum ripple	5%
Inrush current @ 24 V	~10A for 5ms
Rated power @ 24 V	~3W

13.2.2.3 Powered by the PR120/V module

For a full explanation of the features of the PR120/V, see par. 15.1.

13.2.3 Environmental characteristics

Operating temperature	-25°C ... +70°C
Storage temperature	-40°C ... +90°C
Relative humidity	0% ... 98% with condensation
Degree of protection (with PR122/P installed in the CB)	IP 30

13.2.4 Description of inputs/outputs

13.2.4.1 Binary opto-insulated inputs

- **K51/SZin:** Zone selectivity: input for protection S (only with Vaux)
- **K51/Gzin:** Zone selectivity: input for protection G (only with Vaux)

13.2.4.2 Binary opto-insulated outputs

- **K51/SZout:** Zone selectivity: output for protection S (only with Vaux)
- **K51/GZout:** Zone selectivity: output for protection G (only with Vaux)

13.2.5 Communication bus

Local internal bus on rear connector; RS485 physical interface, ABB SACE protocol
External system bus, RS 485 physical interface, Modbus RTU protocol, baud rate 9600-19200 bps.

13.2.6 Protection functions

The PR122/P protection unit carries out 7 independent protection functions. In particular:

1. Protection against overload with inverse time "L";
2. Protection against short-circuit with adjustable delay "S";
3. Protection against instantaneous short-circuit "I";
4. Protection against earth fault with adjustable delay "G";
5. Protection against instantaneous short circuit at high currents "Inst";
6. Protection against phase unbalance "U";
7. Protection against overtemperature "OT";

Model	L2234			Apparatus	Emax	Scale
				Doc.No.	1SDH000460R0002	Page No. 42/155

The PR122/P unit allows current signal processing of the neutral pole with different relationships relative to the value of the phases.
N.B.: Beyond 15.5xIn of current on the Ne, the protection is considered as being set to 100%.

A timing indication (message + "alarm" LED) is provided on the unit's display, which is activated during a protection alarm. It is disabled when the alarm condition ceases or when the protection has been tripped. When the circuit breaker opens, the page with the "Trip" data is displayed (when "i Test" is pressed, or automatically in the presence of Vaux).

With the optional PR120/V module, the PR122/P unit also has the following protection functions:

8. Protection against undervoltage "UV";
9. Protection against overvoltage "OV";
10. Protection against residual voltage "RV";
11. Protection against reverse active power "RP";
12. Underfrequency "UF";
13. Overfrequency "OF";

13.2.6.1 Calculating the RMS and peak

All the protection functions do their respective processing on the basis of the real rms value of the currents and voltages (the protection G is disabled for current values greater than $8 I_n$ [where $I_4 \geq 0.8 I_n$], greater than $6 I_n$ [where $0.5 I_n \leq I_4 < 0.8 I_n$] and greater than $4 I_n$ [where $I_4 < 0.5 I_n$]). If the waveform has a deformation beyond the declared limit ($6.3 @ 2I_n$), the tolerance for the calculation of the true rms value will increase. With the optional PR120/V module, the UV, OV, RV voltage protections always work on the basis of the true rms value of the voltages.

13.2.6.2 Mains frequency

The PR122/P unit constantly measures the frequency of the mains voltages it is connected to.

If the frequency goes out of the permitted range by $\pm 10\%$ in relation to the rated frequency selected (50 or 60Hz), the "warning" LED comes on and the warning message is displayed (see par. 13.6.3).

The signal can be combined with a relay of the PR120/K module or with those of the PR021/K unit.

13.2.6.3 Harmonic distortion

The PR122/P unit signals that a peak factor of 2.1 has been exceeded with a warning message and the "warning" LED lighting up (remember that the IEC 60947-2 standard annex "F" establishes that the protection unit must function regularly with a peak factor ≤ 2.1 , up to $2x I_n$).

The signal can be combined with a relay of the PR120/K module or with those of the PR021/K unit.

13.2.6.4 Circuit-breaker state

If an auxiliary supply is used, or it is powered from the optional PR120/V, the PR122/P unit records the state of the circuit breaker by means of specific wiring on the circuit breaker. In the case where the presence of current is determined with the circuit-breaker in the "OPEN" state, a state error is signaled by a warning message being displayed (see par. 13.6) and the "warning" LED lighting up.

The signal can be combined with a relay of the PR120/K module or with those of the PR021/K unit.

13.2.7 Measurement functions

The current measuring (ammeter) function is available on all versions of the SACE PR122/P unit.

The display shows histograms with the currents of the three phases and of the neutral on the main page. In addition, the current of the phase under the greatest load is given in numerical form. Where applicable, the earth fault current is displayed on a separate page.

The ammeter functions both in self-supply mode and with an auxiliary supply. In the latter case, the display is backlit and the ammeter is always active. The tolerance for the ammeter measuring chain (current sensor plus relay) is described in paragraph 13.2.9.11.2.

- Currents: three phases (L1, L2, L3), neutral (N), earth fault;
- Instantaneous current values over a given time interval (data logger)
- Maintenance: number of operations, percentage of contact wear, opening data storage (latest 20 trips and 20 events).

When the optional PR120/V is connected, the following additional measurement functions are provided:

- Voltage: phase-phase, phase-neutral, residual voltage;
- Instantaneous voltage values over a given time interval (data logger);
- Power: active, reactive, apparent;
- Power factor;
- Frequency and peak factor;
- Energy: active, reactive, apparent, meter;
- Maintenance: number of operations, percentage of contact wear, opening data storage.

13.2.8 Watchdog

The PR122/P unit provides some watchdog functions able to guarantee the proper management of relay malfunctions. These functions are as follows:

- Watchdog for presence of Auxiliary power supply with "plug" icon displayed.
- Rating PLUG validity.
- Watchdog for proper connection of the current sensors (CS). Any anomalies are indicated by a special alarm message and the "alarm" LED coming on, and the circuit breaker opens after 1s.
- Watchdog for proper connection of the Trip Coil (TC). Any anomalies are indicated by a special alarm message and the "alarm" LED coming on; if the PR120/D-M module is installed, this activates the coil opening command (YO), thus opening the CB.
- Watchdog for protection of Hw Trip. In the event of the sensors being disconnected or a Rating Plug error, a CB opening command is given by the TC being enabled.

Model	L2234		Apparatus	Emax	Scale
			Doc.No.	1SDH000460R002	Page No. 43/155

13.2.9 Description of the protection functions

13.2.9.1 Protection "L"

The "L" is the only protection that cannot be disabled because it is for self-protection against overloading of the relay itself. The types of trip curves settable are divided into two groups according to the standard they refer to.

Standard trip curve according to IEC 60947-2

Only one type of curve is settable ($t=k/I^2$) as defined by the IEC standard 60947-2. The protection trip time - inverse time - is given by the expression:

$$\frac{9 \cdot t_r}{(I_f/I_1)^2} \quad \text{where } I_f \leq 12I_n \text{ and } 1 \text{ s where } I_f > 12I_n \text{ where } I_f \text{ is the fault current and } I_1 \text{ the protection threshold.}$$

NB: Time expressed in seconds.

Standard trip curve according to IEC 60255-3

There are 3 types of curves settable, defined by the IEC standard 60255-3 as A, B and C. The protection trip time - inverse time - is given by the expression

$$t = \frac{k}{(I)^a - 1} \cdot b \quad \text{where } I = \frac{I_f}{I_1}$$

NB: Time expressed in seconds.

Where I_f is the fault current and I_1 the protection threshold specified by the user.

a and k are two parameters, suggested by the standard, which vary the type of slope selected (e.g. for type B slope $a = 1$ and $k = 13.5$); b is a parameter introduced by SACE to increase the number of curves with the same slope.

13.2.9.1.1 Thermal memory "L"

The thermal memory function can be enabled for cable protection. It is based on the "τL" parameter defined as the trip time of the curve (t_1) selected at $1.25 \times I_1$.

The release trip time is certainly 100% of the one selected, after an interval τL has passed since the last overload or since the last trip. Otherwise, the trip time will be reduced, depending on the overload which has occurred and on the time that has elapsed.

The PR122/P is fitted with two instruments to make up this thermal memory. The first is only effective when the release is powered (it also records overloads that have not lasted long enough to trip the release), while the second works even when the release is not powered, reducing any trip times in the case of an immediate reclosing and is enabled as soon as the CB is tripped.

It is the PR122/P release that automatically decides which of the two to use, according to the various situations.

NB: The thermal memory function can only be set if the type of curve selected is the standard one ($t=k/I^2$) (see par. 13.2.9.1).

13.2.9.2 Protection "S"

This protection can be disabled; it can be of the fixed time ($t=k$) or inverse time ($t=k/I^2$) type; in the latter case, the trip time is given by the expression:

$$\max \left[\frac{100 \cdot t_2}{(I)^2}, t_2 \right] \quad \text{where } I_f > I_2 \quad \text{where } I_f \text{ is the fault current and } I_2 \text{ the protection threshold.}$$

NB: Time expressed in seconds.

13.2.9.2.1 Thermal memory "S"

The thermal memory function can be enabled for cable protection in the case where the curve with inverse time is selected. This is based on the "tS" parameter defined as the trip time of the curve (t_2) selected at $1.5 \times I_2$. The other characteristics are the same as those for thermal memory "L" (see par. 13.2.9.1.1).

13.2.9.2.2 Start-up threshold "S"

The start-up function can be selected in the case where the curve with fixed time is selected.

The function can be disabled and it is a setting characteristic of the single protection units.

The start-up function enables the protection threshold (S, I and G) to be changed during a time interval lasting "ts", starting from "start-up". The latter must be intended as follows:

- Turning on of the relay, under self-supply;
- Passage of the peak value of the maximum current over $0.1 \times I_n$. A new start-up is possible after the current has dropped below $0.1 \times I_n$.

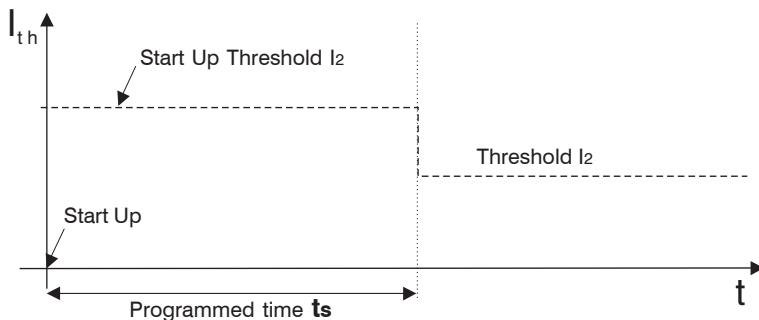

• Start-up time

The start-up time is common to all the protections involved.

Range: 0.1 s ... 1.5 s, with steps of 0.01 s.

Model	L2234			Apparatus	Emax	Scale
				Doc.No.	1SDH000460R0002	Page No. 44/155

13.2.9.2.3 Zone selectivity "S"

The zone selectivity function, guaranteed only if an auxiliary voltage is provided, enables the area of the fault to be isolated, only isolating the part of plant nearest to the fault, while keeping the rest of the plant operational.

This is done by connecting all the zone selectivity outputs of the releases belonging to the same zone to one another (ZSO=K51/SZout) and taking this signal to the zone selectivity input (ZSI=K51/SZin) of the next release on the supply side. If the wiring has been done correctly, all the zone selectivity inputs of the last circuit-breakers in the chain and all the outputs of the circuit-breakers at the head of each chain must be empty.

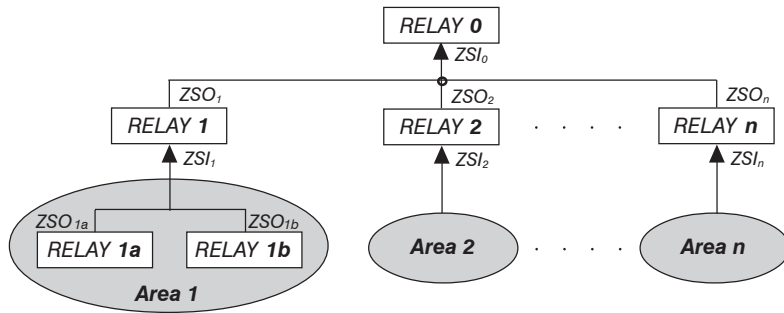

As a practical example, the figure above shows a fault on the load side of the "Relay 1a" isolated by the latter without the "Relay 1" or the "Relay 0" being affected; a fault immediately downstream from the "Relay 1" will be isolated by the latter without the "Relay 0" being affected, thus ensuring that the Areas 2...n remain operational.

The ZSO output can be connected to a maximum of 20 ZSI relays on the supply side in the selectivity chain.



The maximum length of cable for zone selectivity, between two units, is 300 meters. Use corded shielded two-wire cable (see note A to par. 11.2.2). The shield must only be earthed on the circuit-breaker of the supply-side relay (ZSI side).

Wiring and enabling zone selectivity "S" is an alternative to using protection "D" (if any) and operation is only guaranteed when there is an auxiliary voltage.

The following logical table is implemented to manage the Zone Selectivity Input (ZSI) and Zone Selectivity Output (ZSO) signals:

Zone selectivity	$I_{max} > I_2$	ZSI signal	ZSO signal	Trip T
Excluded	NO	0	0	No trip
Excluded	NO	1	0	No trip
Excluded	YES	0	0	t_2 programmed
Excluded	YES	1	0	t_2 programmed
Inserted	NO	0	0	No trip
Inserted	NO	1	1	No trip
Inserted	YES	0	1	$t_{selectivity}$
Inserted	YES	1	1	t_2 programmed

The time t_2 must be set at a value corresponding to at least $t_{selectivity} + 50$ ms.

13.2.9.3 Protection "I"

The protection is enabled/disabled from the menu.

In the case where zone selectivity "S" is active, during the trip of the relay for "I", the ZSO (or DFW and BFW) output signal is activated in any case to guarantee correct operation of the relay on the supply side (and on the load side).

13.2.9.3.1 Start Up Threshold "I"

The start-up function can be selected.

The function can be enabled from the menu on the protection "I" page.

The function behaves in exactly the same way as the protection "S" (see par. 13.2.9.2).

13.2.9.4 Protection "G"

This protection can be disabled; it can be of the fixed time ($t=k$) or inverse time ($t=k/i^2$) type; in the latter case, the trip time is given by the expression

$$\max \left(\frac{2}{i^2}, t_4 \right) \text{ where } I = I_f / I_4, I_f \text{ is the fault current and } I_4 \text{ is the protection threshold.}$$

NB: Time expressed in seconds.



It is possible to disable the trip control of the protection ("EnableTrip: Off"). For the whole duration of the earth fault, circuit-breaker opening does not take place, but only the alarm condition is signaled ("Alarm" LED lit and alarm message).

Model	L2234		Apparatus	Emax	Scale
			Doc.No.	1SDH000460R0002	Page No. 45/155

The PR122/P unit can provide two different types of earth fault protection:

Internal protection G

This is provided inside the relay by vectorially summing the phase and neutral currents. The fault current is defined by the following formula:

$$\vec{I}_G = \vec{I}_1 + \vec{I}_2 + \vec{I}_3 + \vec{I}_N$$

In the case when the circuit does not show any fault, the module of the sum of these currents is always nil; vice versa the value of the fault current will take on an increasingly large value depending on the size of the fault. This operating mode is enabled by default.

N.B.: it can be used also with CS for an external neutral.

Protection G with external toroid "Source Ground Return"

Also called "Source Ground return", this can be carried out when there is the need to check operation of a machine (transformer, generator or motor etc.) which has star-configured windings.

The protection is assured by physically positioning an external toroid on the cable connected from the star center of the machine to the earthing connection point.

The induced current on the winding of the toroid is proportional to the fault current which, in this case, only transits in the above-mentioned toroid. To work in this mode, "Ground protection" must be selected on the Circuit breaker Settings menu.



The external toroid must be connected to the PR122/P by means of a corded shielded two-wire cable (see note A in par. 11.2.2) with a length not exceeding 15m. The shield must be earthed both on the circuit-breaker side and on the toroid side.

It is indispensable for the star center to be connected openly to earth and for it not to be used as a neutral conductor too (as in the TNC system), making a protection according to the TT system.

The protections G and Gext can be enabled simultaneously.

13.2.9.4.1 Start Up Threshold "G"

The start-up function can be selected in the case where the curve with fixed time is selected.

The function can be enabled and disabled on the protection "G" page.

The function behaves in exactly the same way as the protection "S" (see par. 13.2.9.2.2).

13.2.9.4.2 Zone selectivity "G"

The zone selectivity function can be enabled providing the fixed time curve, the wiring and the zone selectivity "G" enabling alternative to the one for "D" have been selected and the function is assured only if auxiliary voltage is provided.

Zone selectivity "G" can be active at the same time as zone selectivity "S".

The behavior and wiring of the function are identical to those indicated for zone selectivity "S" (see par. 13.2.9.2.3).

13.2.9.5 Protection against phase unbalance "U"

The protection with fixed time, which can be excluded, trips in the case when, for a time greater than or the same as the time **t6** set, an unbalance is determined between two or more phases higher than the set threshold **I6**.

The percentage of unbalance is therefore calculated $\%_{unb} = \frac{I_{max} - I_{min}}{I_{max}} \cdot 100$ where I_{max} is the maximum and I_{min} is the minimum phase current.



It is possible to disable the trip control of the protection ("Enable Trip: Off"). In that case, for the whole duration of the unbalance the CB will not be opened, but only the condition will be signaled by means of the "warning" LED lit up and a warning message. When the value of the phase current is above 6xIn, the function "U" excludes itself because, in this case, the other protections intervene because the fault is considered as a phase fault. The protection is not enabled for maximum phase current values lower than 0.3xIn.

13.2.9.6 Protection against overtemperature inside the relay, "OT"

There is a sensor inside the PR122/P unit that monitors the temperature of the unit.

This enables the signalling of any abnormal temperature conditions, which could cause temporary or continuous malfunctions of the unit's electronic components.

This protection has two states of operation:

State of "WARNING TEMPERATURE" with -25°C < temp. < -20°C or 70°C < temp. < 85°C : the display is turned off and the "WARNING" LED flashes

State of "ALARM TEMPERATURE" with temp. < -25°C or temp. > 85°C : the display is turned off,

the "WARNING" led remains on and the Trip is activated (if enabled by means of the "Over Temper. Trip = On" parameter).

N.B.:

- In the event of Warning and Alarm, the display is momentarily turned off, to preserve its functionality.
- The monitored temperature is not visible on the display.

The protection is always active, both with auxiliary supply and in self-supply.



Disabling the Trip control of the protection means that the PR122/P unit could work, with the circuit-breaker closed, in a range of temperatures where correct operation of the electronics is not guaranteed.

Model	L2234			Apparatus	Emax	Scale
				Doc.No.	1SDH000460R0002	Page No. 46/155

13.2.9.7 Load control function

Single loads can be enabled/disabled on the load side before the overload protection L intervenes and trips the circuit breaker on the supply side. This is done by contactors or switch-disconnectors (wired outside the release), controlled by the PR122/P by means of contacts on the PR120/K module or on the PR021/K external unit.

The current thresholds are lower than those available with the protection L, so that the load control can be used to prevent tripping due to overloads. The function is active when an auxiliary power supply is present, or supply from PR120/V (see par. 15.1.4)
The operating logic involves the activation of three contacts when the preset thresholds LC1, LC2 and I_w are exceeded. Thresholds LC1 and LC2 are expressed as a percentage of I_1 (current threshold specified for protection L) while the "warning current" I_w is expressed as an absolute value. The allowable values are given in the following table:

Warning current I_w	0.30 ÷ 3.00 step 0.05x I_n
Threshold LC1	50% ÷ 100% step 1% x I_1
Threshold LC2	50% ÷ 100% step 1% x I_1

From the PR122/P you can associate each of the PR120/K or PR121/K contacts with a configuration (NO or NC), a delay and the eventual latch.

13.2.9.8 Voltage protections "UV", "OV", "RV" (PROTECTIONS AVAILABLE ONLY WITH THE ADDITIONAL PR120/V MODULE)

The PR122/P unit provides 3 voltage protections, which can be disabled, with fixed adjustable time ($t = k$), active both with self-supply and with auxiliary supply:

- Undervoltage "UV"
- Overvoltage "OV"
- Residual voltage "RV"

The protections work on the voltages. The threshold voltages indicated refer to the line voltage.

Apart from the normal timing and "Trip" operation, the voltage protections can be in a state defined as "alarm" (with the "emergency" led on and an alarm message displayed) providing there is an auxiliary or PR120/V module power supply. In fact, in the case where the circuit-breaker is open and no current is detected, the timing leads to the "alarm" state and not to "TRIP". This is because the fault linked to the voltages can persist even with the circuit-breaker open and the unit would therefore always be under "timing". When the circuit-breaker is closed or the passage of a current is detected, you pass immediately from the state of "alarm" to "TRIP" without timing (see par. 13.3.2).

13.2.9.8.1 Protection "UV"

When the minimum phase voltage drops below the set threshold U_g the protection counts down the preset time interval t_g and then opens.

13.2.9.8.2 Protection "OV"

When the maximum phase voltage exceeds the set threshold U_g the protection counts down the preset time interval t_g and then opens.

13.2.9.8.3 Protection "RV"

When the residual voltage exceeds the set threshold U_{10} the protection counts down the preset time interval t_{10} and then opens.

The residual voltage U_0 is calculated by vectorially summing the phase voltages. It is therefore defined by the following formula

$$\vec{U}_0 = \vec{U}_1 + \vec{U}_2 + \vec{U}_3$$

13.2.9.9 Reverse active power protection "RP"(AVAILABLE ONLY WITH THE ADDITIONAL PR120/V MODULE)

The PR122/P unit provides protection (which can be disabled) with an adjustable fixed time ($t = k$), against reverse active power, active both with self-supply and auxiliary supply.

When the total reverse active power (sum of the power of the 3 phases) exceeds the set reverse active power threshold P_{11} , the protection counts down the preset time interval t_{11} and then opens.

The minus sign ("-") in front of the threshold and power indicates reverse power. The threshold is indicated as a percentage of "Pn", where "Pn" is the rated power of the circuit-breaker ($3 \sqrt{3} V_n I_n$).

13.2.9.10 Frequency protections "UF", "OF"(AVAILABLE ONLY WITH THE ADDITIONAL PR120/V MODULE)

The frequency protections record the mains frequency variations above an adjustable threshold (f_{12} , t_{12}) or below (f_{13} , t_{13}), generating an alarm or the opening of the circuit breaker.

Model	L2234		Apparatus	Emax	Scale
			Doc.No.	1SDH000460R0002	Page No. 47/155

13.2.9.11 Summary table of the protection function settings for the PR122/P

Protection	Disabling	Disabling of TRIP only	Zone selectivity	Start-up threshold	Thermal memory	Trip Threshold	Trip Time	Threshold tolerance ⁽²⁾	Trip time tolerance ⁽²⁾
L ($t=k/i^2$) curve IEC 60255-3	<input type="checkbox"/>	<input type="checkbox"/>	<input type="checkbox"/>	<input type="checkbox"/>	<input checked="" type="checkbox"/>	$0.4xI_n \leq I_1 \leq 1xI_n$ step 0.01xI _n	$3s \leq t_1 \leq 144s^{(1)}$, step 3s at $I=3xI_1$	Release between 1.05 and 1.2 x I1	$\pm 10\%$, $I_1 \leq 6I_n$ $\pm 20\%$, $I_1 > 6I_n$
S ($t=k$)	<input checked="" type="checkbox"/>	<input type="checkbox"/>	<input checked="" type="checkbox"/>	<input checked="" type="checkbox"/>	<input type="checkbox"/>	$0.6xI_n \leq I_2 \leq 10xI_n$ step 0.1xI _n $0.6xI_n \leq I_{2\text{ start-up}} \leq 10xI_n$ step 0.1xI _n	Min, $0.05s \leq t_2 \leq 0.8s$, step 0.01s $0.10s \leq t_{2\text{ start-up}} \leq 1.5s$, step 0.01s $0.04s \leq t_{2\text{ sel}} \leq 0.20s$, step 0.01s	$\pm 7\%$, $I_1 \leq 6I_n$ $\pm 10\%$, $I_1 > 6I_n$	The best of the two data $\pm 10\%$ or 40 ms
S ($t=k/i^2$)	<input checked="" type="checkbox"/>	<input type="checkbox"/>	<input type="checkbox"/>	<input type="checkbox"/>	<input checked="" type="checkbox"/>	$0.6xI_n \leq I_3 \leq 10xI_n$ step 0.1xI _n	$0.05s \leq t_3 \leq 0.8s$, step 0.01s at 10xI _n	$\pm 7\%$, $I_1 \leq 6I_n$ $\pm 10\%$, $I_1 > 6I_n$	$\pm 15\%$, $I_1 \leq 6I_n$ $\pm 20\%$, $I_1 > 6I_n$
I ($t=k$)	<input checked="" type="checkbox"/>	<input type="checkbox"/>	<input type="checkbox"/>	<input checked="" type="checkbox"/>	<input type="checkbox"/>	$1.5xI_n \leq I_3 \leq 15xI_n$ step 0.1xI _n	≤ 30 ms	$\pm 10\%$	
G⁽⁴⁾ ($t=k$)	<input checked="" type="checkbox"/>	<input checked="" type="checkbox"/>	<input checked="" type="checkbox"/>	<input checked="" type="checkbox"/>	<input type="checkbox"/>	$0.20xI_n \leq I_4 \leq 1xI_n$ step 0.02xI _n	$0.1s \leq t_4 \leq 1s$, step 0.05s $0.1s \leq t_{4\text{ start-up}} \leq 1.5s$, step 0.01s $0.04s \leq t_{4\text{ sel}} \leq 0.2s$, step 0.01s	$\pm 7\%$	The best of the two data $\pm 10\%$ or 40 ms
G⁽⁴⁾ ($t=k/i^2$)	<input checked="" type="checkbox"/>	<input checked="" type="checkbox"/>	<input type="checkbox"/>	<input type="checkbox"/>	<input type="checkbox"/>	$0.20xI_n \leq I_4 \leq 1xI_n$ step 0.02xI _n	$0.1s \leq t_4 \leq 1s$, step 0.05s	$\pm 7\%$	$\pm 15\%$
Gext ($t=k$)	<input checked="" type="checkbox"/>	<input checked="" type="checkbox"/>	<input checked="" type="checkbox"/>	<input checked="" type="checkbox"/>	<input type="checkbox"/>	$0.20xI_n \leq I_4 \leq 1xI_n$ step 0.02xI _n $0.20xI_n \leq I_4 \leq 1xI_n$ step 0.02xI _n	$0.1s \leq t_4 \leq 1s$, step 0.05s $0.1s \leq t_{4\text{ start-up}} \leq 1.5s$, step 0.01s $0.04s \leq t_{4\text{ sel}} \leq 0.2s$, step 0.01s	$\pm 7\%$	The best of the two data $\pm 10\%$ or 40 ms
Gext ($t=k/i^2$)	<input checked="" type="checkbox"/>	<input checked="" type="checkbox"/>	<input type="checkbox"/>	<input type="checkbox"/>	<input type="checkbox"/>	$0.20xI_n \leq I_4 \leq 1xI_n$ step 0.02xI _n	$0.1s \leq t_4 \leq 1s$, step 0.05s	$\pm 7\%$	$\pm 15\%$
Gext (I _{dn})	<input checked="" type="checkbox"/>	<input checked="" type="checkbox"/>	<input type="checkbox"/>	<input type="checkbox"/>	<input type="checkbox"/>	I _{dn} = 0.3-0.5-0.7-1.0 2.0-3.0-5.0-7.0-10-20 30A	0.06-0.10-0.20-0.30-0.40-0.50 0.80-1.00-3.00-4.8s ⁽³⁾	$\pm 10\%$	
U ($t=k$)	<input checked="" type="checkbox"/>	<input checked="" type="checkbox"/>	<input type="checkbox"/>	<input type="checkbox"/>	<input type="checkbox"/>	$5\% \leq I_5 \leq 90\%$ %unb step 5%	$0.5s \leq t_5 \leq 60s$, step 0.5s	$\pm 10\%$	The best of the two data $\pm 10\%$ or 40 ms
OT (temp=k)	<input type="checkbox"/>	<input checked="" type="checkbox"/>	<input type="checkbox"/>	<input type="checkbox"/>	<input type="checkbox"/>	fixed, defined by SACE	Instantaneous	$\pm 1^\circ\text{C}$	- - -
Iinst	<input type="checkbox"/>	<input type="checkbox"/>	<input type="checkbox"/>	<input type="checkbox"/>	<input type="checkbox"/>	Automatic, defined by SACE	Instantaneous	$\pm 5\%$	+1mS
LC1/LC2 loads control	<input checked="" type="checkbox"/>	<input type="checkbox"/>	<input type="checkbox"/>	<input type="checkbox"/>	<input type="checkbox"/>	50%+100% step 0.05xI ₁			
Warning Iw	<input checked="" type="checkbox"/>	<input type="checkbox"/>	<input type="checkbox"/>	<input type="checkbox"/>	<input type="checkbox"/>	0.30+3.00% step 0.05xI _n			

⁽¹⁾ The minimum value of this trip is 1s regardless of the type of curve set (self-protection).

⁽²⁾ These tolerances are based on the following assumptions:

- self-supplied relay at full power (without start-up)
- presence of auxiliary power supply
- two-phase or three-phase power supply
- preset trip time ≥ 100 ms

⁽³⁾ no-trip time

⁽⁴⁾ the protection G is disabled for current values greater than 4I_n, where $I_4 < 0.5I_n$, greater than 6I_n, where $0.5I_n \leq I_4 < 0.8I_n$ and greater than 8I_n where $I_4 \geq 0.8I_n$.

For all cases not covered by the above hypotheses, the following tolerance values apply:

Protections	Trip threshold	Trip time
L	Release between 1.05 and 1.25 x I1	$\pm 20\%$
S	$\pm 10\%$	$\pm 20\%$
I	$\pm 15\%$	≤ 60 ms
G	$\pm 10\%$	$\pm 20\%$
Others		$\pm 20\%$

13.2.9.11.1 Summary of the additional protection functions for the PR122/P with the optional PR120/V module

Protection	Disabling	Disabling of TRIP only	Zone selectivity	Start-up threshold	Thermal memory	Threshold Range	Time Range	Tolerance threshold ⁽²⁾	Time Tolerance ⁽²⁾
UV (t=k)	<input checked="" type="checkbox"/>	<input checked="" type="checkbox"/>	<input type="checkbox"/>	<input type="checkbox"/>	<input type="checkbox"/>	$0.5xU_n \leq U \leq 0.95xU_n$ step 0.01xUn	$0.1s \leq t_g \leq 5s$, step 0.1s	± 5%	± 20%
OV (t=k)	<input checked="" type="checkbox"/>	<input checked="" type="checkbox"/>	<input type="checkbox"/>	<input type="checkbox"/>	<input type="checkbox"/>	$1.05xU_n \leq I_g \leq 1.2xU_n$ step 0.01xUn	$0.1s \leq t_g \leq 5s$, step 0.1s	± 5%	The best of the two data ± 10% or 40 ms
RV (t=k)	<input checked="" type="checkbox"/>	<input checked="" type="checkbox"/>	<input type="checkbox"/>	<input type="checkbox"/>	<input type="checkbox"/>	$0.1xU_n \leq I_{10} \leq 0.4xU_n$ step 0.05 Un	$0.5s \leq t_{10} \leq 30s$, step 0.5s	± 5%	The best of the two data ± 10% or 40 ms
RP (t=k)	<input checked="" type="checkbox"/>	<input checked="" type="checkbox"/>	<input type="checkbox"/>	<input type="checkbox"/>	<input type="checkbox"/>	$-0.3xP_n \leq P_{11} \leq -0.1xP_n$ step 0.02 Pn	$0.5s \leq t_{11} \leq 25s$, step 0.1s	± 10%	The best of the two data ± 10% or 40 ms
UF	<input checked="" type="checkbox"/>	<input checked="" type="checkbox"/>	<input type="checkbox"/>	<input type="checkbox"/>	<input type="checkbox"/>	$0.9f_n \leq f \leq 0.99f_n$ step 0.01 fn	$0.5s \leq t_{12} \leq 3s$, step 0.1s	± 5%	The best of the two data ± 10% or 40 ms
OF	<input checked="" type="checkbox"/>	<input checked="" type="checkbox"/>	<input type="checkbox"/>	<input type="checkbox"/>	<input type="checkbox"/>	$1.01f_n \leq f \leq 1.1f_n$ step 0.01 fn	$0.5s \leq t_{13} \leq 3s$, step 0.1s	± 5%	The best of the two data ± 10% or 40 ms

13.2.9.11.2 Table of measurements

Type of measurement	Range	Tolerance	%
Phase and neutral currents	0.3 ... 6 In		1.5
Internal ground fault current (internal source ground return)	0.3 ... 4 In		1.5
External ground fault current (external source ground return)	0.3 ... 4 In		1.5
Phase-to-phase and phase voltages (measured at the module's input and thus independent of the precision relating to the use of any VT)	$50 V_{\text{phase-to-phase}} \dots 1.1x690 V_{\text{phase-to-phase}}$		1
Residual voltage (for systems with neutral only)	$50 V_{\text{phase-to-phase}} \dots 1.1x690 V_{\text{phase-to-phase}}$		1
Peak factor	0.3 ... 6 In		1.5
Total power factor	0.5 ... 1		2.5
Mains frequency	35 ... 80 Hz		± 0.2
Instantaneous active power on the single phase and total system	0.3 ... 6 Pn		2.5
Instantaneous reactive power on the single phase and total system	0.3 ... 6 Pn		2.5
Instantaneous apparent power on the single phase and total system	0.3 ... 6 Pn		2.5
Active energy	0.3 ... 6 Pn		2.5
Reactive energy	0.3 ... 6 Pn		2.5
Apparent energy	0.3 ... 6 Pn		2.5

Model	L2234		Apparatus	Emax	Scale
			Doc.No.	1SDH000460R0002	Page No. 49/155

13.2.10 Trip curves

The trip curves given are for guidance and only show a sub-group of the possible selections (see par. 13.2.9.11).

13.2.10.1 Trip curves for functions L-I

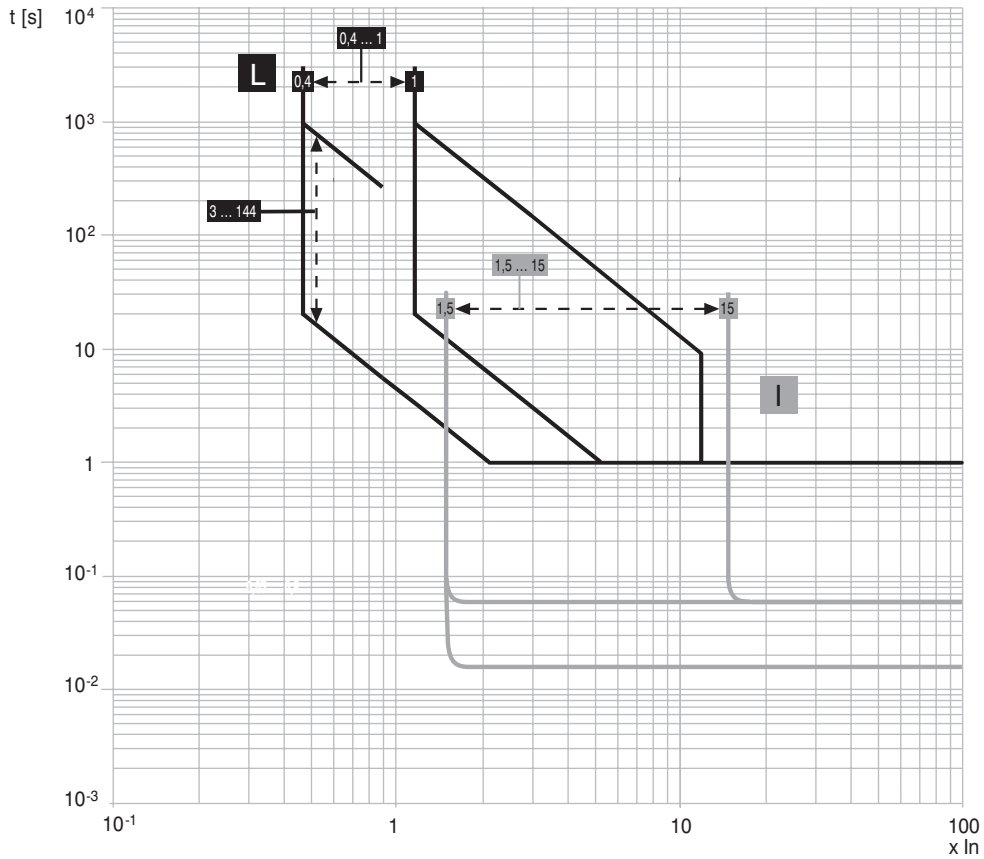

13.2.10.2 Trip curves for functions L-S(t=k/i²)-I

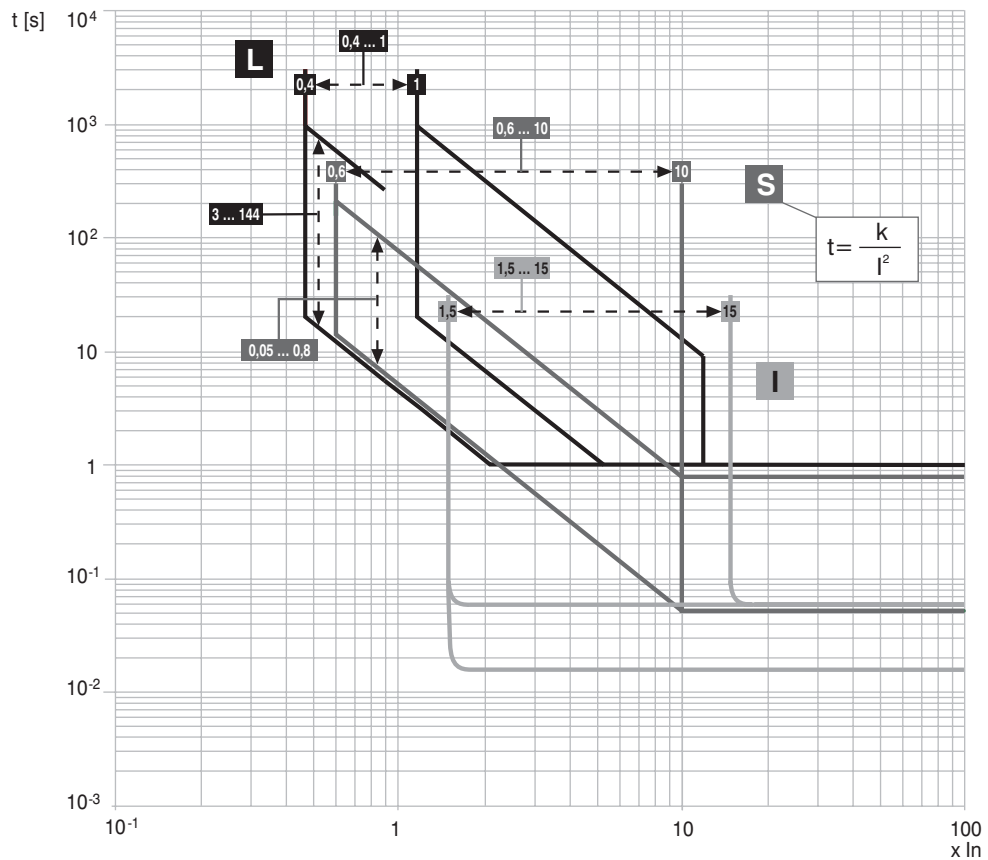

Model	L2234		Apparatus	Emax	Scale
			Doc.No.	1SDH000460R0002	Page No. 50/155

13.2.10.3 Trip curves for functions L-S(t=k)-I

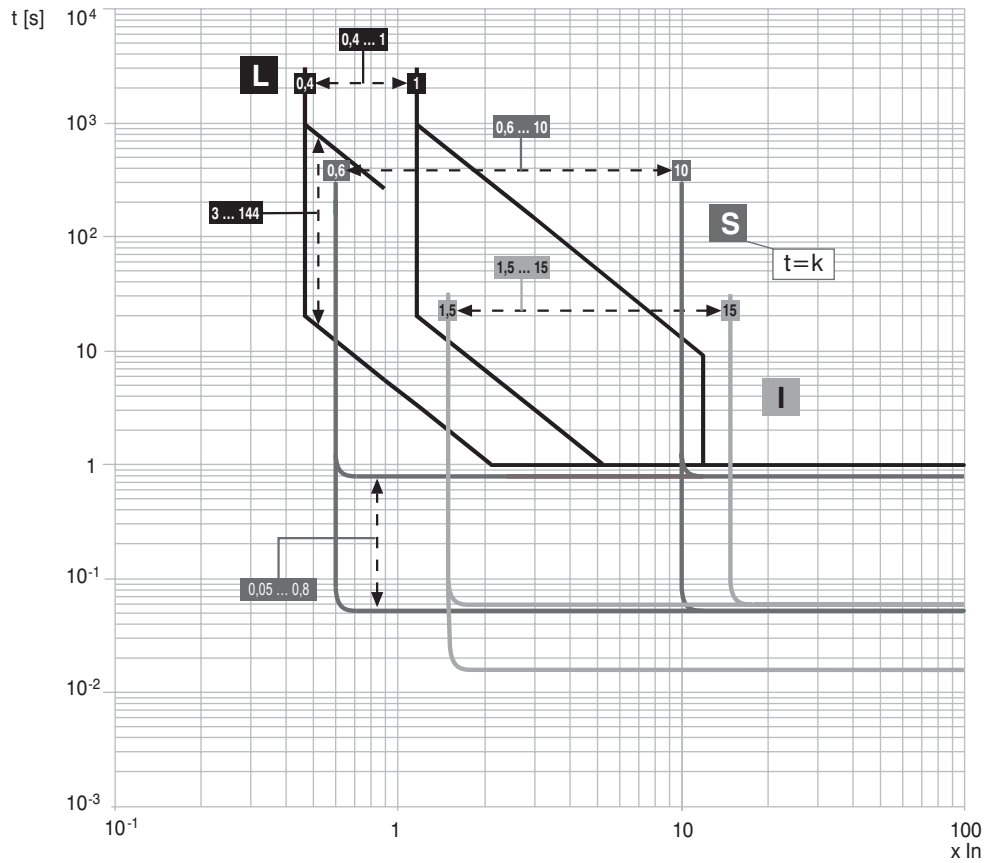

13.2.10.4 Trip curves for function L in accordance with IEC 60255-3 (type A)

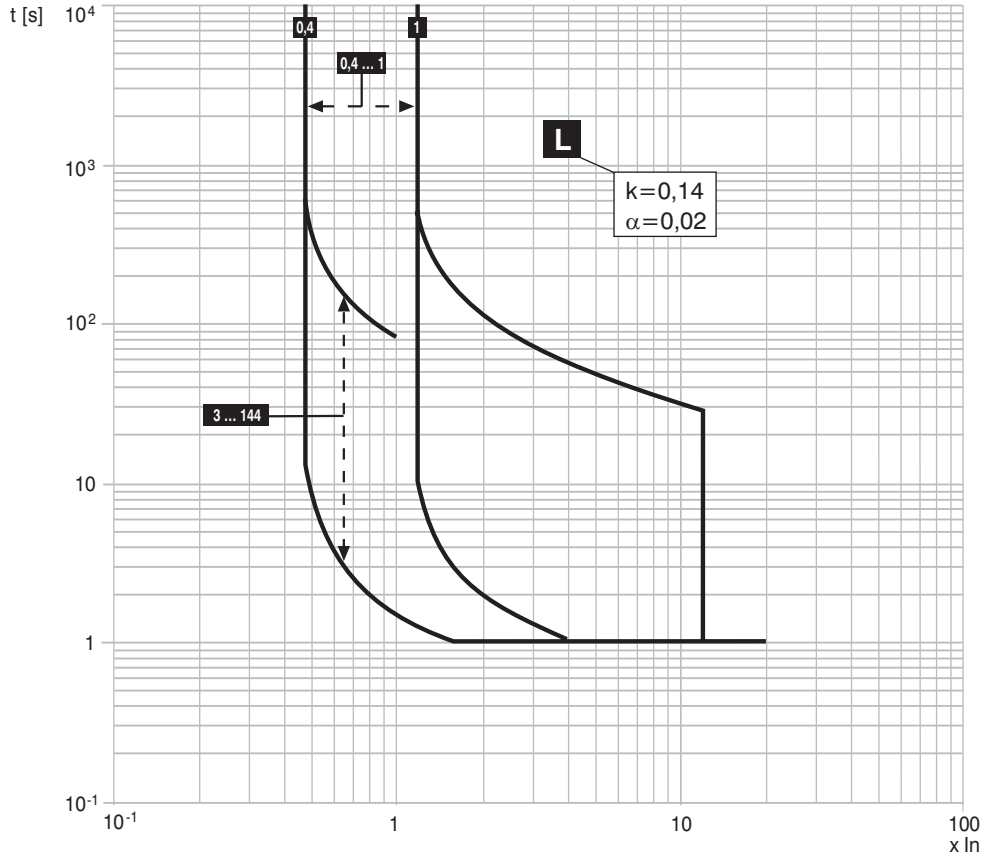

Model	L2234		Apparatus	Emax	Scale
			Doc.No.	1SDH000460R002	Page No. 51/155

13.2.10.5 Trip curves for function L in accordance with IEC 60255-3 (type B)

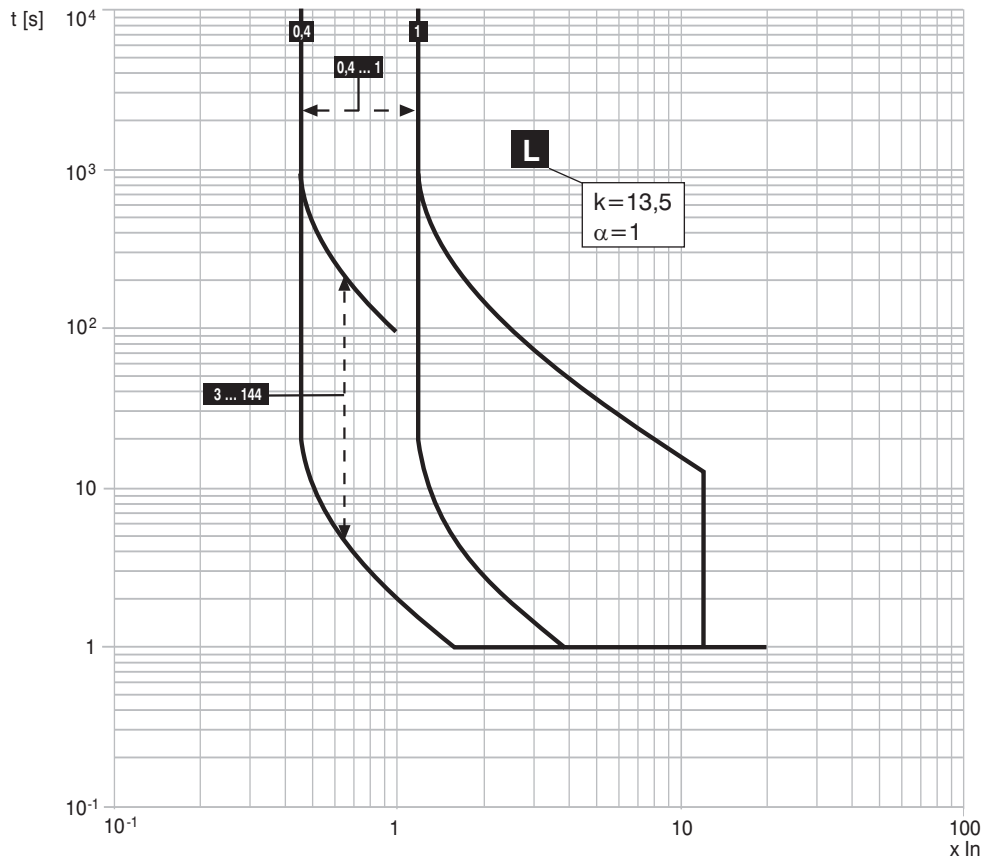

13.4.2.10.6 Trip curves for function L in accordance with IEC 60255-3 (type C)

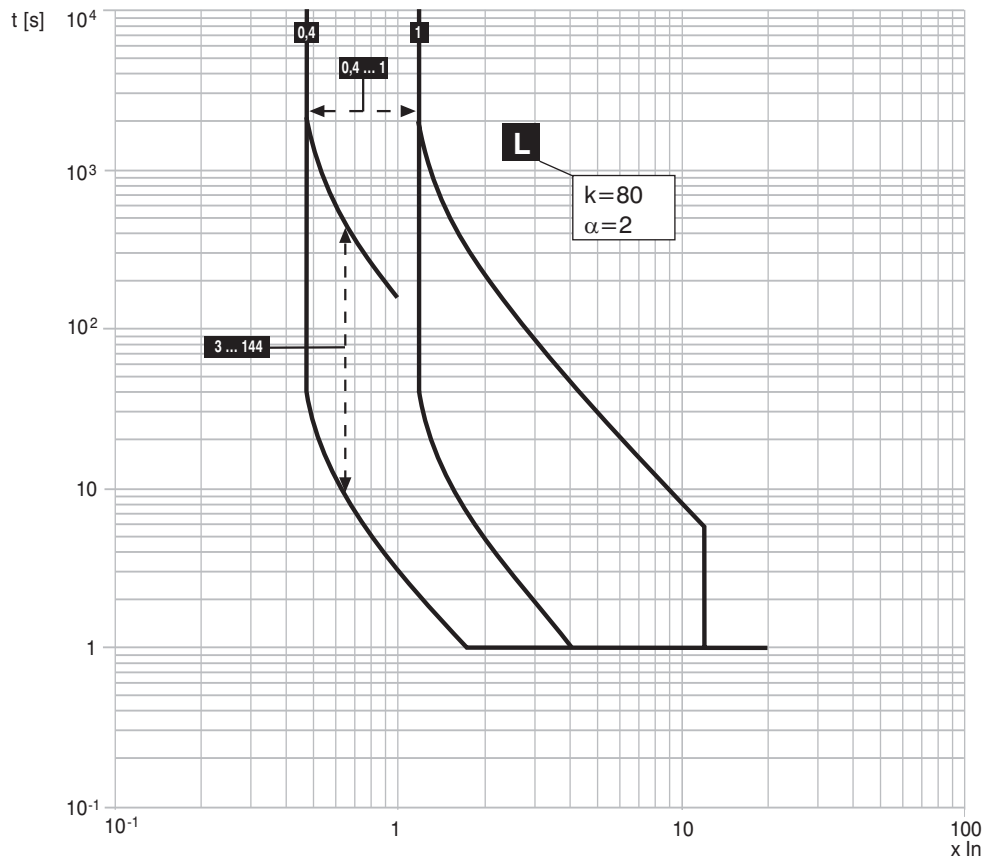

Model	L2234		Apparatus	Emax	Scale
			Doc.No.	1SDH000460R0002	Page No. 52/155

13.2.10.7 Trip curves for function G

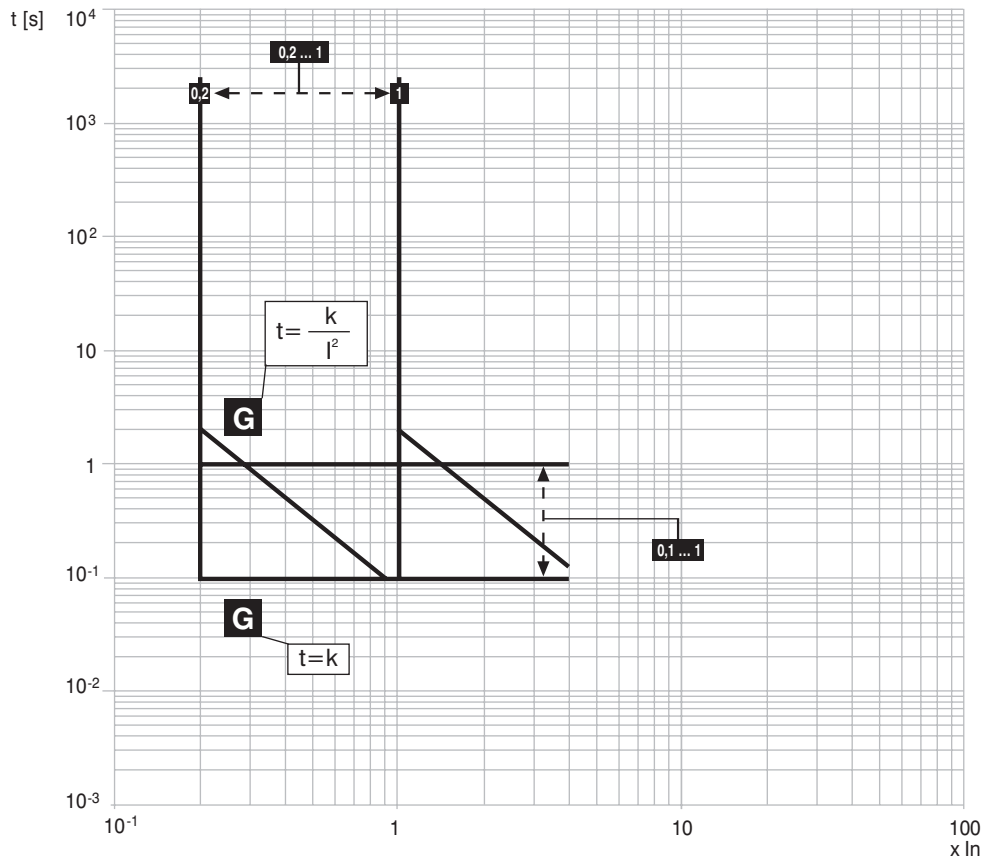

13.2.10.8 Trip curves for function U

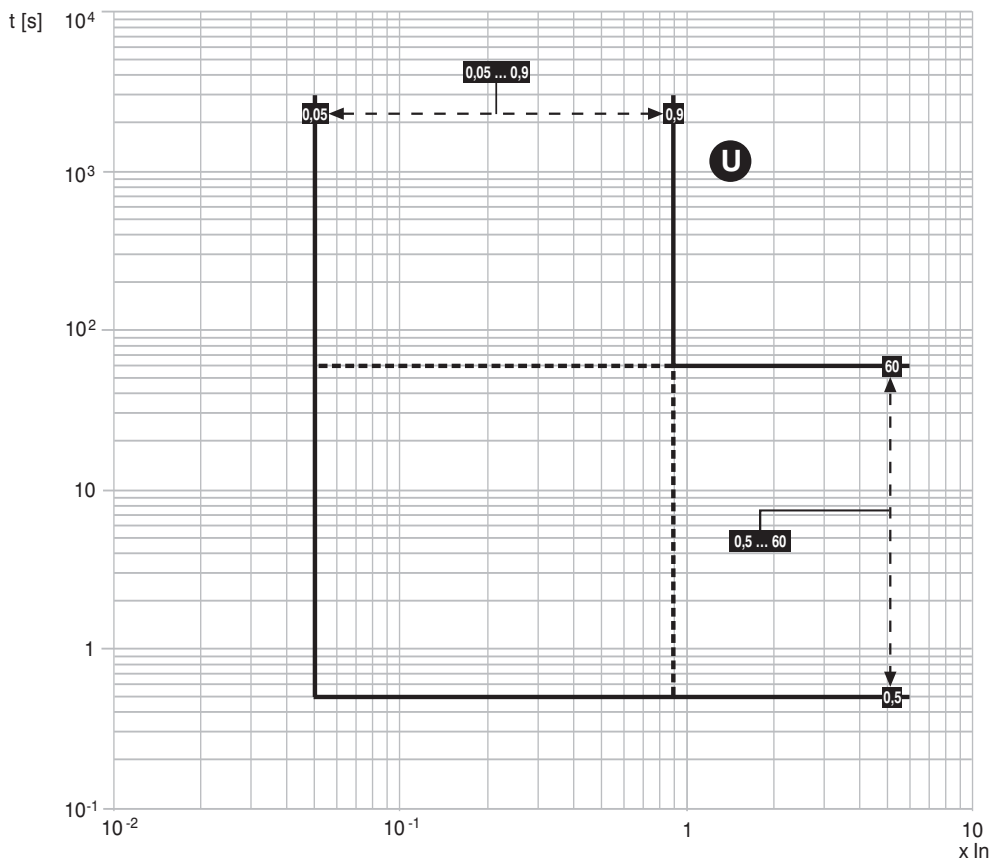

Model	L2234		Apparatus	Emax	Scale
			Doc.No.	1SDH000460R002	Page No. 53/155

13.2.10.9 Trip curves for function UV

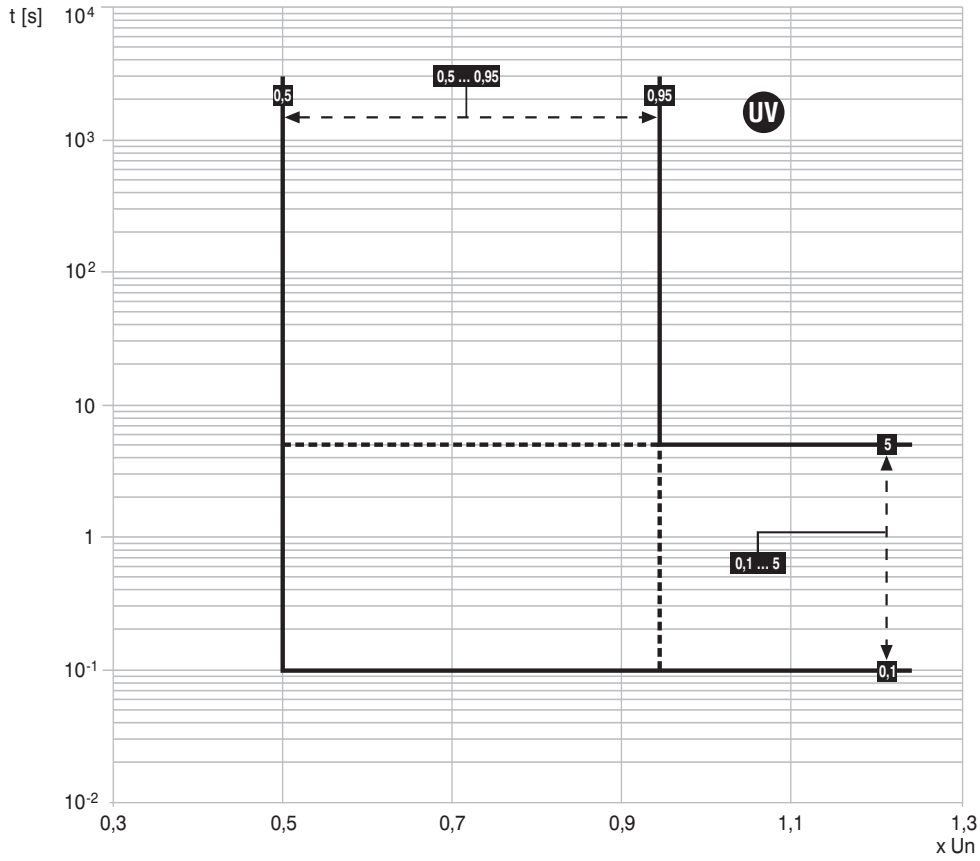

13.2.10.10 Trip curves for function OV

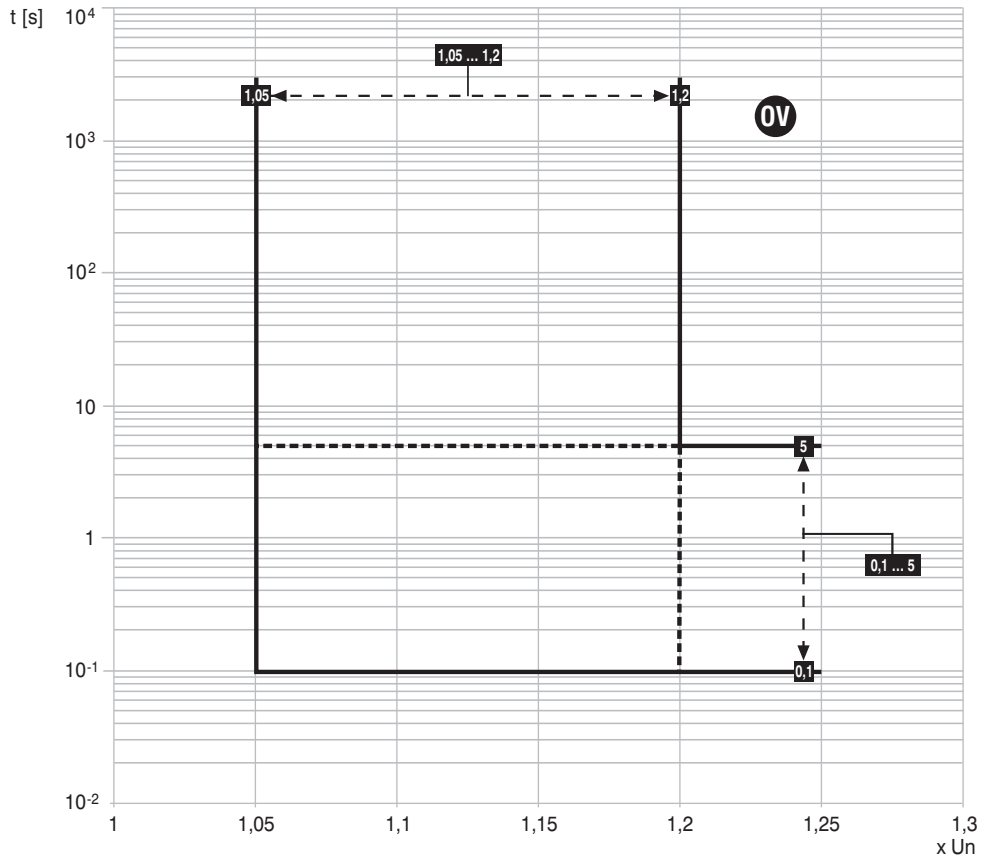

Model	L2234		Apparatus	Emax	Scale
			Doc.No.	1SDH000460R0002	Page No. 54/155

13.2.10.11 Trip curves for function RV

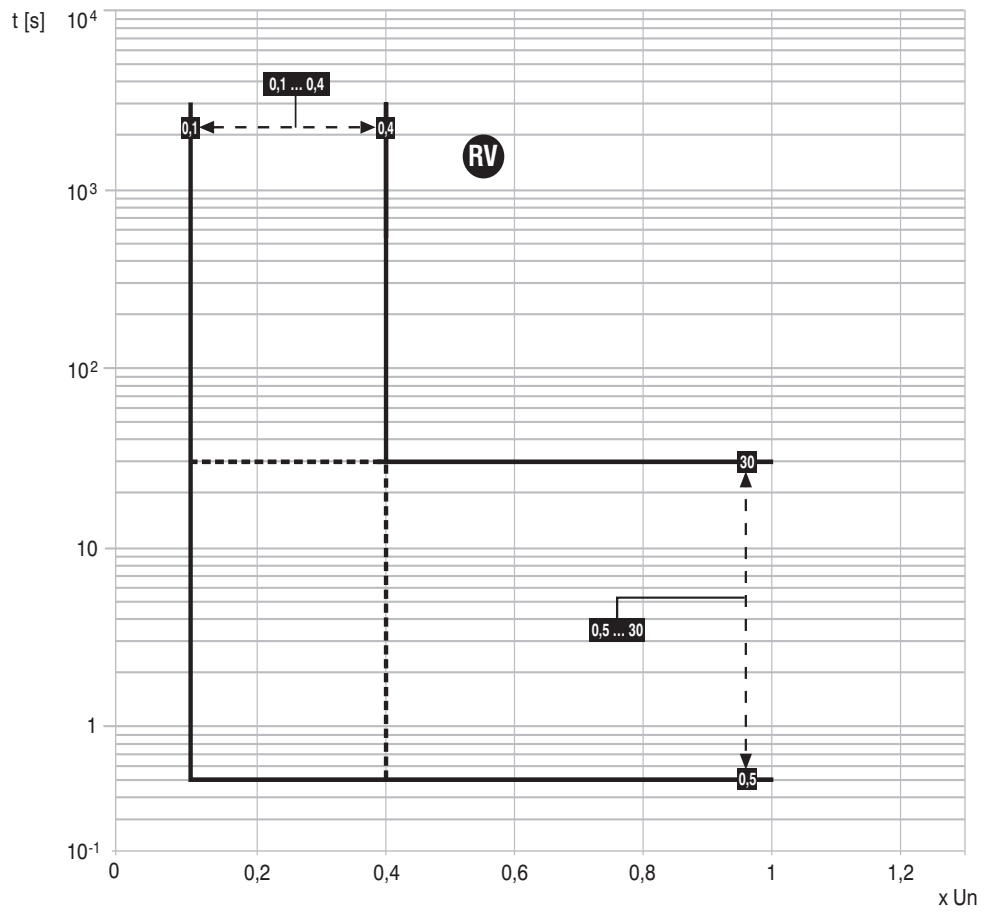

13.2.10.12 Trip curves for function RP

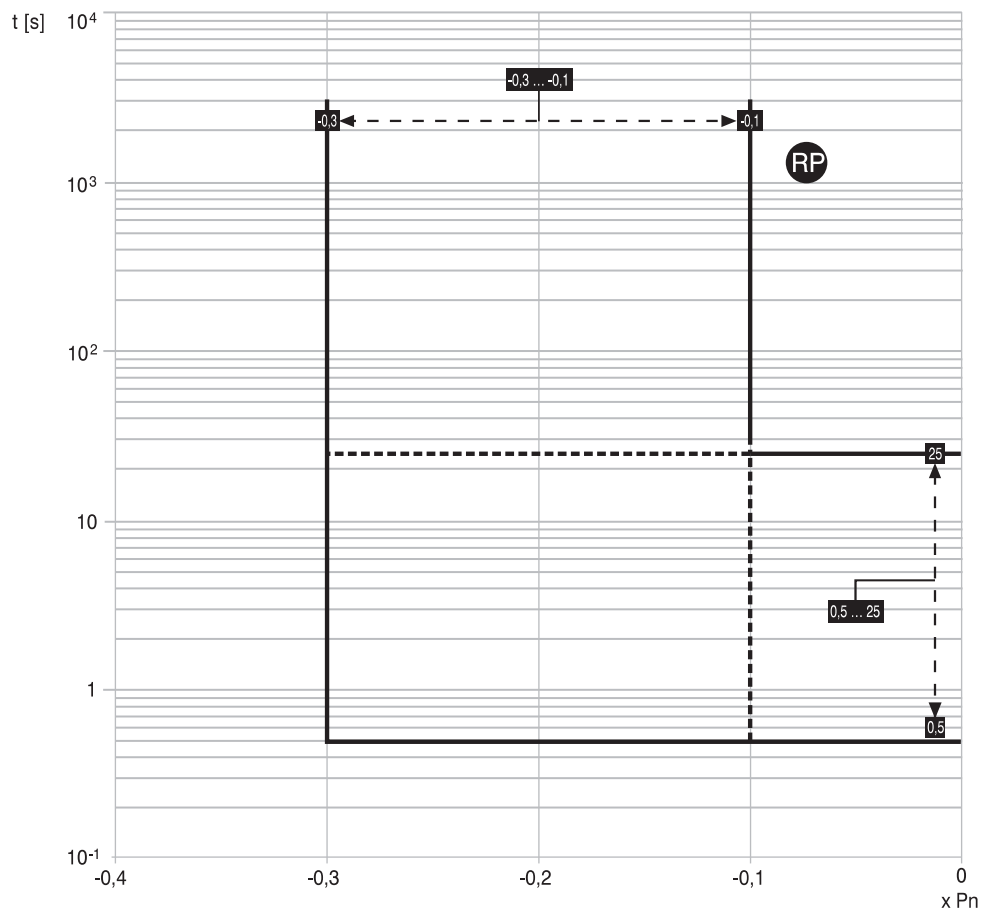

Model	L2234		Apparatus	Emax	Scale
			Doc.No.	1SDH000460R002	Page No. 55/155

13.3 Putting into service

13.3.1 Connections



For the connections provided by the user, it is recommended that you comply strictly with the recommendations contained in this document.

This will enable us to satisfy all the international reference standards and guarantee perfect operation of the relay even under severe environmental and electromagnetic conditions.

Pay particular attention to the types of cable, the connections to earth and the recommended maximum distances.



The maximum length of the VT - PR120/V wiring must not exceed 15 meters.

Use corded shielded two-wire cable (see note A to par. 11.2.2).

The shield must be connected to earth on both sides.



Use VTs with a shield, connected to earth (see standard VT par. 13.3.2).

The VTs should only be used for voltages > 690V; for lower voltages the presence of the PR120/V module connected to the lower or higher busbars will be sufficient.

13.3.1.1 Current sensor connection for external neutral



If you want to connect the current sensor for the external neutral conductor to a three-pole circuit breaker, remember to set INn accordingly. During this procedure, the circuit breaker must be open and preferably isolated.

13.3.2 VT connections



Dielectric strength tests are not allowed on the inputs and outputs of the releases or on the secondary lines of any connected VTs

The following is a summary table of standard VT connections according to the type of plant.

TV Standard (A): Single standard transformers, see par. 15.1.7.

The VTs must have a performance coming between the values of 10 and 20 VA inclusive, 4 kV insulation between the primary and secondary.

Installation system	"VT Standard" type transformer (Star/Star)	"VT Standard" type transformer (Delta/Delta)
TN-C	B	A
TN-S	B	A
IT with neutral	B	A
IT	n.c	A
TT with neutral	B	A
TT without neutral	n.c	A

- Note:**
- for TN-C systems the connection must be made to PEN
 - for TN-S systems the connection must be made to N for configurations with neutral or PE for configurations without neutral; if the PE is used, the current thereon could be around a dozen mA. If a customer considers this value too high or has a residual current protection which risks being tripped, then application diagram A must be used
 - for IT and TT systems with neutral, the connection must be made to N

Application diagram A

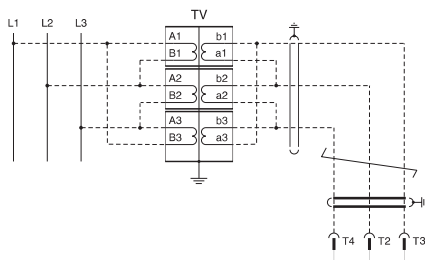

Application diagram B

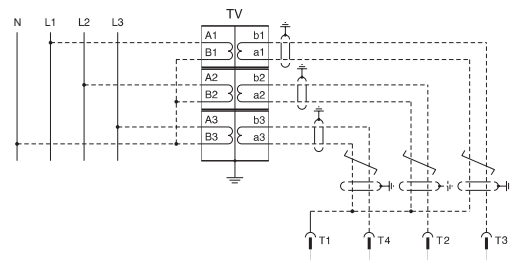

13.3.3 CS and TC connection test



If the PR122/P was installed by the user, it is important, before closing the CB, to check the last line on the display when the relay is turned on for the first time via a PR030/B battery unit. No CS and/or TC disconnected messages must appear; if they do, do not close the circuit-breaker and make the correct connections.

13.3.4 Test

Before putting into service, a test can be conducted by means of the specific "Auto test" function which can be activated on the PR122/P. A positive result is shown on the display.

Then a test can be conducted on the whole TC chain, again using the specific function (Trip test). A positive result is shown by the circuit-breaker opening.

Check the open or closed state of the circuit-breaker on the same "PR122/P Test" screen, by checking "CB status".

Test	1/6
CB status	
Auto Test	
Trip Test (disabled)	
	CB open

Model	L2234	Apparatus	Emax	Scale
		Doc.No.	1SDH000460R0002	Page No. 56/155

13.3.5 Initial settings

If the PR122/P is supplied ready installed in the circuit-breaker, it is up to ABB SACE to set all the variables referring to the circuit-breaker or the specific application correctly (e.g. type of circuit breaker, Rating Plug size, mains frequency ...).

Vice versa, if the PR122/P is supplied separately, it will be up to the user to set all the necessary parameters correctly.

Note that ABB SACE defines each possible setting according to the content of the paragraph on the default parameters (see par. 13.4.4).



Apart from this, it is absolutely indispensable for the user to modify the password and carefully define each modifiable parameter, before putting the PR122/P into service.

13.3.6 Password management

Specify a password? [0***]

To enter "EDIT" mode it is necessary to enter a four-figure numerical password. The values attributable to the password go from 0000 to 9999. For the default password see par.13.4.4.

Select the value of the first figure (between '0' and '9') by means of the ↑ and ↓ keys and press ↵ to confirm the figure and then move on to enter the next one.

After entering the fourth figure, check the password you have entered. If the password is correct, you go from the "READ" state to the "EDIT" state.

If the password is wrong, the message

Wrong password

appears and remains until the **ESC** key is pressed (or until an interval of 5 seconds has elapsed).

It is also possible to interrupt the password entry procedure by pressing the **ESC** key.

The password is valid for a maximum of two minutes from the last time a key was pressed. It is immediately reset in the case of a high priority alarm or when the unit is reset.

On entering a page with no modifiable parameters, the state of the protection is put on "READ". If the password is still valid, to enter "EDIT" mode (on a page with modifiable parameters) simply press the ↵ key.

Disabling the Password.



By setting the value of the password to [0000] (on the "Unit configuration" menu) the password prompt is disabled. It is therefore always possible to switch from "READ" to "EDIT".

To enter a new password, select the "New Password" item on the "Settings/System" menu.

13.3.7 Changing the electronic release

13.3.7.1 Installation

To complete the procedure for installing a PR122/P unit, follow the steps below:

1. With the circuit breaker open and preferably isolated, install the protection unit on the circuit breaker
2. Power the unit ONLY from the PR030/B
3. If there are no other errors, the display will show the message  Configuration (configuration error) accompanied by the yellow LED coming on permanently (warning)
4. Enter the unit's "Settings" menu
5. Select "Circuit breaker"
6. Select "Unit installation"
7. Input the password
8. Select "Install" and press "ENTER"
9. When the red led flashes on and off and the message  Installation (installation error) is displayed, remove the PR030/B
10. Power the relay from any other source

Check for the absence of configuration errors.

13.3.7.2 Uninstalling

To complete the procedure for uninstalling a PR122/P unit, follow the steps below:

1. With the circuit breaker open and/or isolated power the unit from the PR030/B
2. Enter the unit's "Settings" menu
3. Select "Circuit breaker"
4. Select "Unit installation"
5. Input the password
6. Select "Uninstall" and press "ENTER"
7. If there are no error messages, remove the PR030/B
8. Remove the PR122/P unit from the circuit breaker
9. The remove the TC connector, proceed as indicated in the figure alongside.

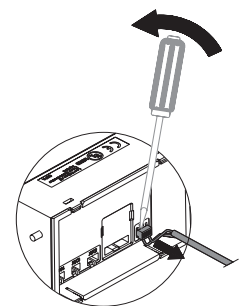

It is not strictly necessary to complete the uninstalling procedure, but this enables the parameters relating to the circuit breaker, such as contact wear and others, to be saved in the "KEY PLUG", otherwise these data would be lost. The data in question are then transmitted to the new PR122/P unit installed on the same circuit breaker.

Model	L2234		Apparatus	Emax	Scale
			Doc.No.	1SDH000460R002	Page No. 57/155

13.4 User interface

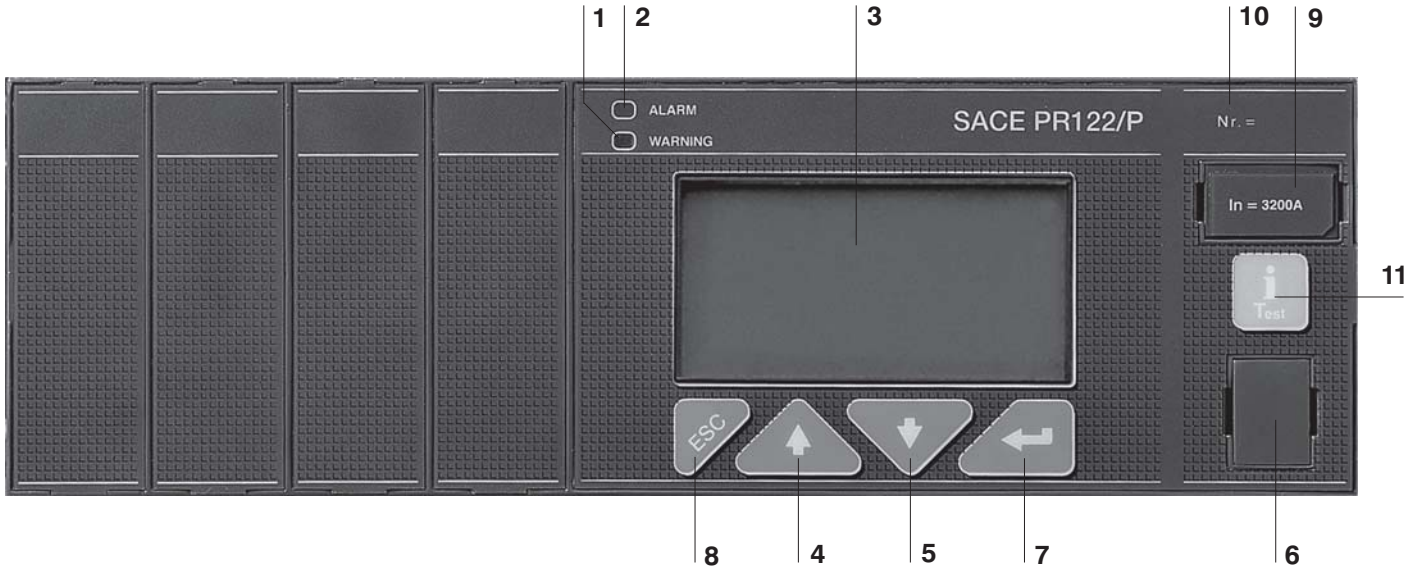

Ref.	Description
1	Pre-alarm indicator LED
2	Alarm indicator LED
3	Graphic display (the word ABB in the bottom left-hand corner indicates normal operation)
4	Serial number of the PR122/P
5	Rating plug
6	Pushbutton for exiting the sub-menus or for canceling (ESC)
7	Button for the cursor (UP)
8	Button for the cursor (DOWN)
9	ENTER key for confirming the data or changing the page
10	TEST connector for connecting or testing the release by means of an external device (PR030/B battery unit, BT030 wireless communication unit and PR010/T test unit)
11	"i Test" test and info button

The Graphic Display is of the LCD type with 128x64 pixels and it is backlit when there is an auxiliary voltage or a self-supply from a PR120/V module. The display is always lit when there is a Vaux or, in self-supply mode with a minimum busbar current or powered from the PR120/V module as defined in par 13.2.2.1.

You can adjust the contrast on the display by means of the specific function available on the user interface settings menu (par. 13.5.4.1).

13.4.1 Use of pushbuttons

The modifiable fields can be filled in using the ↑ or ↓ keys and confirming with the ↵ key. Once you have entered the page you need, you can move from one value to another by using the ↑ or ↓ keys. To change a value, position the cursor over the value (the modifiable field will appear in reverse, i.e. white on a black background), and use the ↵ key.

To confirm the programming of the previously configured parameters, press the **ESC** key once only. A check will be carried out on the parameters entered and then the programming confirmation page will be displayed. To return to the main menu, press the **ESC** key twice.

The "i Test" key must be used to perform the Trip test to view the information page and to see the last trip within 48 hours of the CB opening in self-supply mode.

13.4.2 Read and Edit modes

The menu map (see par. 13.5.1) shows all the pages which can be obtained and how to move between them from the keyboard, in the "READ" mode (just to read the data) or in the "EDIT" mode (to set the parameters).

Starting from any page displayed, two different functions can be obtained according to the state of the unit:

- "READ": the default page will be displayed automatically after about 120 seconds (see par. 13.5.1).
- "EDIT": the default page will be displayed automatically after about 120 seconds.

The allowable functions depending on the state are:

"READ":

- ✓ Consultation of the measurements and of the historical data
- ✓ Consultation of the unit configuration parameters
- ✓ Consultation of the protection parameters





Model	L2234		Apparatus	Emax	Scale
			Doc.No.	1SDH000460R0002	Page No. 58/155

“EDIT”:

- ✓ Everything allowed in READ mode
- ✓ Configuration of the unit
- ✓ Programming of the parameters relative to the protections
- ✓ TEST Functions of the unit

To access the "EDIT" mode, it is necessary to press the \downarrow key on a page with fields which can be edited. A password will then be required to enable you to switch to the editing mode.

The use of the keys is summarized in the following table:

Key	Function
	Move between pages Move within menu Change parameter values
	End setting phase and confirm result Choose menu item
	Access to surfing menus from the default page Return to previous level when surfing within the menus, until you return to the default pages Exit the parameter changing phase, aborting the change
	This key is used to re-enable the display after it has gone off within 48 hours of the opening of the circuit breaker in self-supply mode.

13.4.3 Changing parameters

Moving within the Main Menu you can reach all the pages relating to the configurations and parameter settings with the opportunity to change the values specified for the parameters.

After any programming, you need to Confirm/Cancel/Change any changes you have made. This procedure is not applicable to all the programming activities.

Two examples are provided below: one concerns the case in which no confirmation is needed for the changes you have made, while in the other a confirmation window appears.

Procedure not requiring the confirmation of any programming

For instance, to set the System Date, the correct sequence is as follows:

From the default page press ESC
to access the Main Menu



From the Main Menu, select SETTINGS

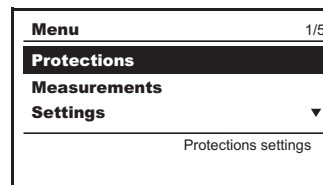

press the \downarrow key (enter)

Select SYSTEM

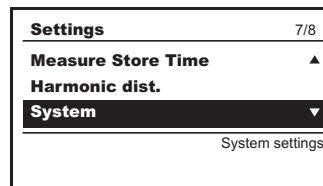

press the \downarrow key (enter)

Select the menu item DATE to change

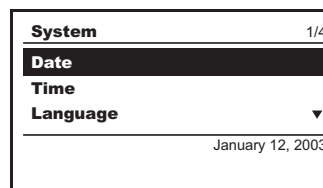

press the \downarrow key (enter)

Model	L2234			Apparatus	Emax	Scale
				Doc.No.	1SDH000460R002	Page No. 59/155

You will be prompted to input a Password
complete the password entry procedure (par.13.3.6)

press the ↵ key (enter)

A screenshot of a terminal window titled "Password". It shows a cursor at the beginning of a line with "0***" and the prompt "Enter password" at the bottom right.

Change the date using the keys ↓ (arrow down)

↑ (arrow up) and confirm by pressing the ↵ key (enter).

Press ESC twice to return to the Main Menu.

A screenshot of a terminal window titled "Date". It shows the date "January 12, 2004" centered on the screen.

Procedure requiring the confirmation of any programming

For instance, to change the Curve of the Protection L, the correct sequence is as follows:

From the default page press ESC
to access the Main Menu

A screenshot of the main menu showing a bar chart with four bars labeled V1, V2, V3, L1, L2, L3, LN. The time is 10:22:53 and the current setting is 400 A (I₁).

From the Main Menu select the item PROTECTIONS

press the ↵ key (enter)

A screenshot of the "Protections" menu. It shows a list with "Protections" selected, followed by "Measurements" and "Settings". The page number is 1/5 and "Protections settings" is at the bottom.

From the Protections Menu select the item PROTECTION L

press the ↵ key (enter)

A screenshot of the "L Protection" menu. It shows a list with "L Protection" selected, followed by "S Protection" and "I Protection". The page number is 1/13 and "Overload" is at the bottom.

From the Protection L Menu select the item CURVE

press the ↵ key (enter)

A screenshot of the "L Protection" menu showing the "Function" section. It lists "Threshold I1" and "Time T1". The page number is 1/4 and the formula $t=k/I^2$ is at the bottom.

You will be prompted to input a Password (par. 13.3.6)

complete the password entry procedure

press the ↵ key (enter)

A screenshot of a terminal window titled "Password". It shows a cursor at the beginning of a line with "0***" and the prompt "Enter password" at the bottom right.

Model	L2234			Apparatus	Emax	Scale
				Doc.No.	1SDH000460R0002	Page No. 60/155

Select the value you want from the list and confirm pressing the ↵ key (enter).

Press ESC twice

Before accessing the Main Menu, the following box will appear:

Accept the new configuration
 Reject the new configuration (the previous configuration is retained)
 Change the previously input values.

To select the required option use the ↓ (arrow down), ↑ (arrow up) keys, and press ↵ (enter) to confirm.

Function	1/4
t=k/i²	
t=0.14b/(t^{0.02}·1)	
T=13.5b/(i-1)	▼

Programming	1/3
Confirm	
Abort	
Modify	
	Confirm

13.4.3.1 Modification of basic configuration

No parameter settings can be made if the PR122/P unit is in alarm conditions.

The configuration of the unit must be done in EDIT mode.

Following the instructions given in par. 13.4.3, view the following on the display:

Change system date
 Change system time
 Select system language

System	2/4
Date	
Time	
Language	▼
	07:56:28

System	4/4
Time	▲
Language	
New Password	
	**** ⓘ

Password
0***
Enter password

To change the system password, select the relevant menu item and press ↵ (enter); then you will be prompted to enter the OLD password, and afterwards you can input the new one twice.
 Press ESC twice to return to the Main Menu

Before accessing the Main Menu, the following box will appear:

Accept the new configuration
 Reject the new configuration (the previous configuration is retained)
 Change the previously input values.

Programming	1/3
Confirm	
Abort	
Modify	
	Confirm

Model	L2234			Apparatus	Emax	Scale
				Doc.No.	1SDH000460R002	Page No. 61/155

13.4.4 Default settings

The PR122/P is supplied by ABB SACE with the following predefined parameters:

#	Protection	On/Off	Thresholds	Time	Curve	T.M.	ZS	Trip
1	L	-	1 In	144 s	I ² t	Off	-	-
2	S	Off	6 In	50 ms	K	-	Off: 0.04s	-
3	I	On	4 In	-	-	-	-	-
4	G	Off	0.2 In	0.4 s	K	-	Off: 0.04s	On
5	U	Off	50 %	5 s				Off
6	OT	-						Off
7	K LC1	Off	50 % I ₁					
8	K LC2	Off	75 % I ₁					
9	UV	Off	0.9 Un	5 s				Off
10	OV	Off	1.05 Un	5 s				Off
11	RV	Off	0.15 Un	15 s				Off
12	RP	Off	- 0.1 Pn	10 s				Off
13	UF	Off	0.9 Fn	3 s				Off
14	OF	Off	1.1 Fn	3 s				Off
15	Language	-	Engl					
16	Net Frequency	-	50 Hz					
17	PR021/K	Off						
18	Neutral sel.	-	50 %					
19	Toroid Selec.	-	None					
20	Ext. ground tor.	Off	100 A					
21	Vs Un	-	380 V					
22	S startup	Off	6 In	100 ms				
23	I startup	Off	4 In	100 ms				
24	G startup	Off	1 In	100 ms				
25	Password	-	0001					
26	Measuring interval	-	60 min					
27	Iw	Off	3 In					
28	Power direction	-	top → bottom					
29	Harmonic dist. warning	Off						

Model	L2234			Apparatus	Emax	Scale
				Doc.No.	1SDH000460R0002	Page No. 62/155

Each time the unit is turned on, or after more than 2 minutes of inactivity on the keyboard, the display indicates the following page (default):

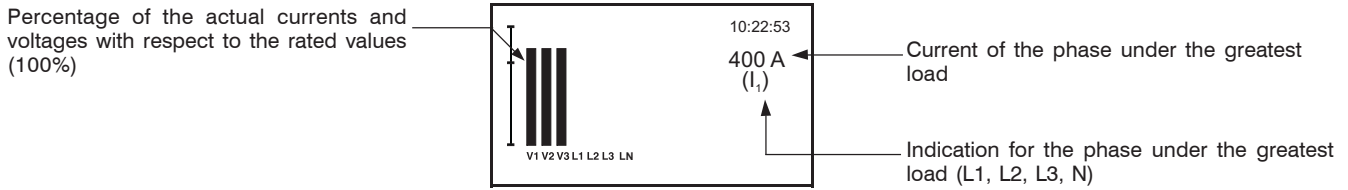

13.5.2 Protections menu

From the interface you can press ENTER to access the menu of the various protections available on the display

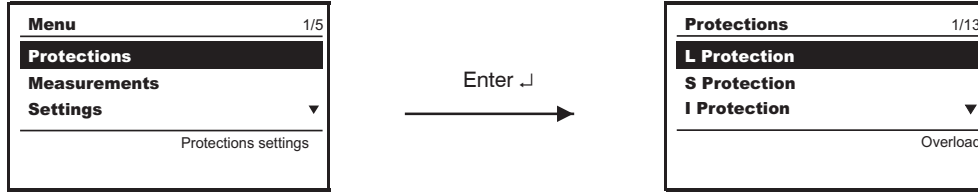

Using the "arrow UP" and "arrow DOWN" you can view the various protections.

On the whole, the data that you can display when the optional additional PR120/V module is installed concern the protections: L, S, I, G, U, UV, OV, RV, RP, UF, OF, OT, LOAD PROTECTION.

Example of surfing the Protections menu

From the Protection main page you can press ENTER to go to the Protection L Menu.

You can use "arrow UP" and "arrow DOWN" to select the items on the menu and confirm by pressing ENTER. Pressing this key triggers a Password prompt, then you can select the functions associated with the protection L (as in the example)

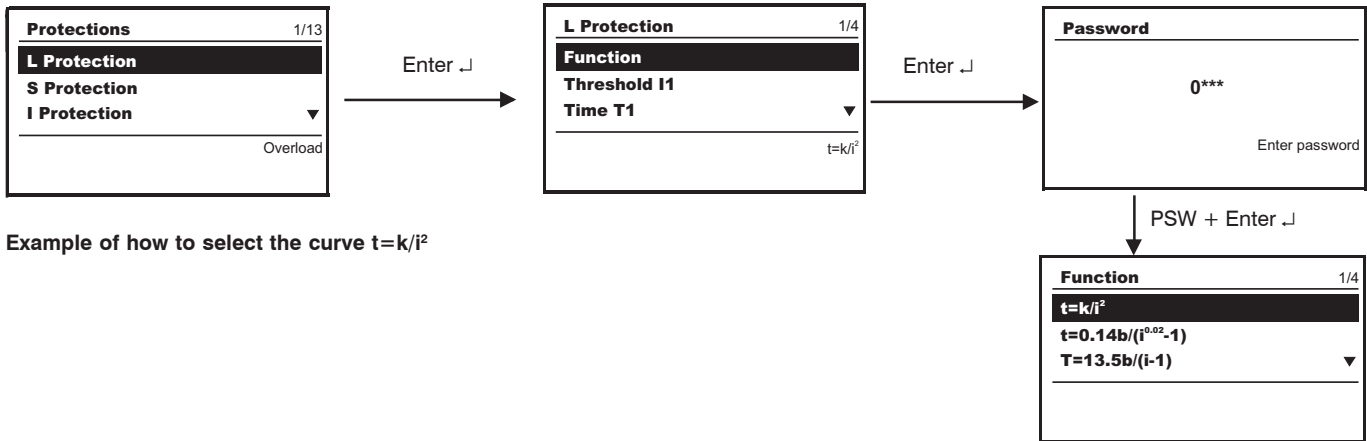

Example of how to select the curve $t=k/i^2$

Similarly, to access the menus for the other protections, see the Protections Menu table below.

13.5.2.1 Protections menu table

Protection	Parameter / Function	
L	Curve	
	Threshold I1	
	Time t1	
	Thermal memory	ON / OFF
S	Enable	ON / OFF
	Curve	
	Threshold I2	
	Time t2	
	Zone selectivity	ON / OFF
	Selectivity time	

Model	L2234		Apparatus	Emax	Scale
			Doc.No.	1SDH000460R0002	Page No. 64/155

Protection		Parameter / Function	
	Enable StartUp		ON / OFF
	StartUp threshold		
	StartUp time		
I	Enable		ON / OFF
	Threshold I3		
	Enable StartUp		ON / OFF
	StartUp threshold		
	StartUp time		
Gext	Enable		ON / OFF
	Curve		
	Threshold I4		
	Time t4		
	Enable Trip		ON / OFF
	Zone selectivity		ON / OFF
	Selectivity time		
	Enable StartUp		ON / OFF
	StartUp threshold		
	StartUp time		
U	Enable		ON / OFF
	Threshold I6		
	Time t6		
	Enable Trip		ON / OFF
UV	Enable		ON / OFF
	Threshold U8		
	Time t8		
	Enable Trip		ON / OFF
OV	Enable		ON / OFF
	Threshold U9		
	Time t9		
	Enable Trip		ON / OFF
RV	Enable		ON / OFF
	Threshold U10		
	Time t10		
	Enable Trip		ON / OFF
RP	Enable		ON / OFF
	Threshold P11		
	Time t11		
	Enable Trip		ON / OFF
UF	Enable		ON / OFF

Model	L2234		Apparatus	Emax	Scale
			Doc.No.	1SDH000460R0002	Page No. 65/155

	Threshold f12	
	Time t12	
	Enable Trip	ON / OFF
OF	Enable	ON / OFF
	Threshold f13	
	Time t13	
	Enable Trip	ON / OFF
OT	Enable Trip	ON / OFF
Load Control	Threshold 1 Enable Threshold	ON / OFF
	Threshold 2 Enable Threshold	ON / OFF
	Threshold lw Enable Threshold	ON / OFF

Note: for an explanation of the characteristics of the single protections and their settings and corresponding curves, see par. 13.2.9.

Model	L2234			Apparatus	Emax	Scale
				Doc.No.	1SDH000460R0002	Page No. 66/155

13.5.3 Measurements Menu

For a complete description of the functions of the PR120/V module, see par. 15.1.
The following is a summary of the parameters accessible from the menu in the PR122/P unit.

13.5.3.1 Measurements Menu table

Setting	Parameter / Function	Values	Notes
Historicals			
	Trips		Last trip
	Events		Events log
	Measurements		
	I Max		Current
	Reset measurements		
Peak factor			
Contact wear			
			Percentage of wear on CB contacts

13.5.4 Settings Menu

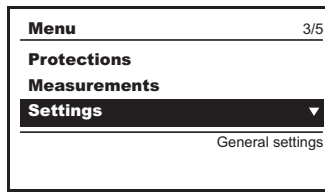

The configuration parameters in the Settings menu are password protected. Among the most significant values you can select, note the neutral threshold (values 50%, 100%, 150%, 200%), the external toroid size (values 100 A, 250 A, 400 A, 800 A), the mains frequency at the installation (values 50 Hz, 60 Hz). For a more detailed description of the settings for the modules, refer to the documentation on the modules (ch. 15).

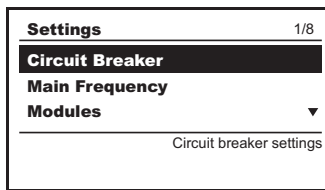

Enter ↵

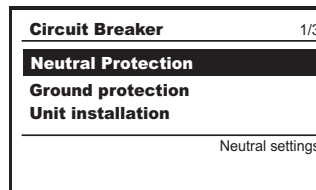

Enter ↵ + PWD

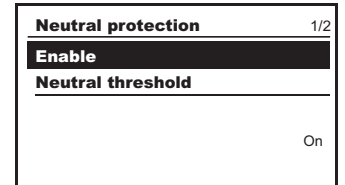

13.5.4.1 Settings Menu table

	Parameter / Function	Values	Notes
Circuitbreaker	Neutral protection		
	Enable	ON/OFF	
	Neutral threshold	50%-100%-150%-200%	
	Ground protection		Said protection is provided only in the event of an external toroid being used
	External toroidal transformer	Absent,SGR,Rc	
	Toroid size SGR		
	Toroid size Rc	Idn = 1A, 10A	
Mains frequency		50 Hz - 60Hz	
Modules	Module		
	PR120/V - Measuring	if any	see par. 13.5.4.4.1
	PR120/D-M - COM	if any	see par. 13.5.4.4.2
	PR120/K - Signalling	if any	see par. 13.5.4.4.3
	Local Bus unit	Absent - Present	
Data logger	Enable	ON/OFF	
		Sampling frequency	
		Stop event	
		Stopping delay	
		Restart	
		Stop	
Measurement interval		from 5 to 120 min, step 5 min	
Harmonic distortion		ON/OFF	The warning indicates that the distortion exceeds factor 2.1

Model	L2234		Apparatus	Emax	Scale
			Doc.No.	1SDH000460R002	Page No. 67/155

Parameter / Function	Values
System	Date Time Language New password
Display	Contrast

The summary table relates to the surfing of the pages dedicated to the PR120/V module (see par. 15.3) and to the PR021/K unit (see par. 16.1).

13.5.4.2 Neutral adjustment

The neutral protection is normally set to a current value 50% of the adjustment made on the phases.

In some installations, where particularly high harmonics occur, the current circulating on the neutral may be higher than that of the phases.

In the SACE PR122/P release, this protection can be set for the following values : $I_n = 50\% - 100\% - 150\% - 200\% \cdot I_n$.

The values that can be used to adjust the neutral are given in the table below for the various possible combinations between types of circuit-breaker and adjustment of the threshold I_n .

13.5.4.2.1 Neutral adjustments table

Adjustment for the threshold I_n (L Protection)			
Circuit breaker size	$I_n \leq 0.5$	$0.5 < I_n \leq 0.66$ ⁽¹⁾	$I_n > 0.66$
E1	50-100-150-200%	50-100-150%	50-100%
E2	50-100-150-200%	50-100-150%	50-100%
E3	50-100-150-200%	50-100-150%	50-100%
E4	50-100%	50%	50%
E4/f	50-100-150-200%	50-100-150%	50-100%
E6	50-100%	50%	50%
E6/f	50-100-150-200%	50-100-150%	50-100%

Nota 1: The adjustment $I_n = 1$ In is meant as the maximum adjustment of the overload protection. The actual maximum allowable adjustment must take into account any temperature derating, the terminals used and the altitude.

 **Failure to comply with the setting limits for “ I_n ” and “ $I_n N$ ” can cause circuit breaker damage with consequent risks even for the operator.**

In any case, the relay records any setting error between I_n and the Neutral setting and it signals this by means of the warning (see par. 13.6.3).

13.5.4.3 Mains frequency settings

In the mains frequency menu, you can choose between the frequency values: 50, 60 Hz.

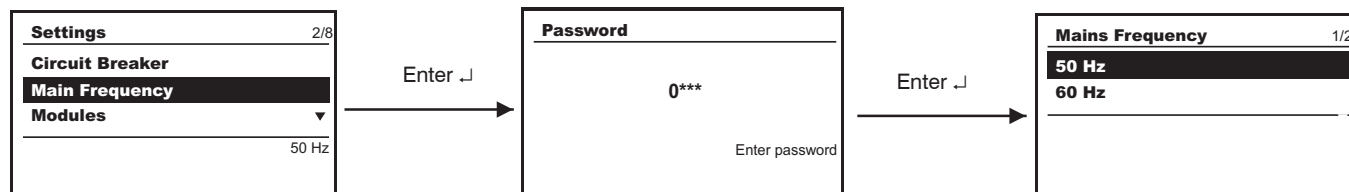

13.5.4.4 Modules

When you access the Settings menu, there is a set of menus available relating to the modules.

13.5.4.4.1 PR120/V - MEASURING module

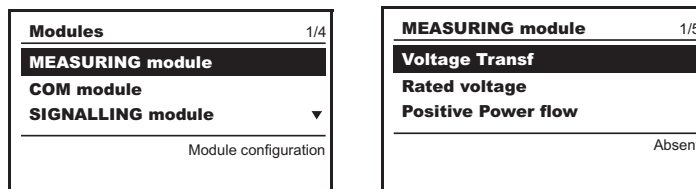

In the measuring module you must enter a password and can then opt for the absence or presence of the voltage transformer. Moreover, you can select the values of the primary voltage (100, 115, 120, ... 1000V) and secondary voltage (100, 110, ..., 230V). The power flow can be LOW -> HIGH or HIGH-> LOW. After entering a password you can choose whether the neutral connection is to be Absent or Present. The phase sequence and $\cos\phi$ signal can be enabled and disabled (ON /OFF) and the corresponding threshold values can be selected (see par. 15.1).

Model	L2234			Apparatus	Emax	Scale
				Doc.No.	1SDH000460R0002	Page No. 68/155

13.5.4.4.2 PR120/D-M - COM module

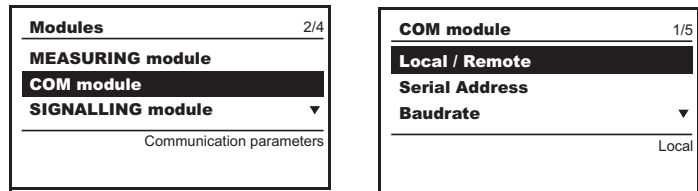

The local or remote modes can be selected after entering a password. The serial address can be displayed after entering a password. The Baud Rate can be set on the values 9600 and 19200 bit/s. The physical protocol provides for the options: (8,E,1), (8,0,1), (8,N,2), (8,N,1). The addressing can be selected as standard Modbus or ABB. For further information on the PR120/D-M communication module, see paragraph 15.2 in this manual.

13.5.4.4.3 PR120/K - SIGNALLING module

For a thorough examination of the signalling module, refer to the corresponding section of the module, paragraph 15.3.

13.5.4.4.4 PR120/D BT WL-COM module

This module is for wireless communication based on the Bluetooth standard between the PR122/P protection release and a hand-held PC (PDA) or a laptop with a Bluetooth port. For further information, see the description of the module in paragraph 15.4.

13.5.4.4.5 Settings for the Local Bus unit

If the PR021/K unit is connected, you need to enable the local bus by selecting present.

13.5.5 Test Menu

Access to the Test menu is password protected.

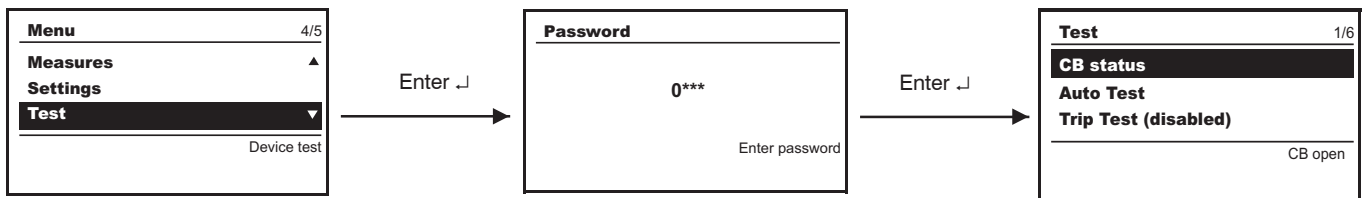

The menu shows the state of the CB, in the dialog module (COM module) the state of the springs and the position of the CB, and in this submenu you can make the CB open or close.

Using the "Trip Test" function lets you view the disabling/enabling of the Trip. If it is enabled, the circuit breaker is opened. The function is only available with a busbar current of nil (use Vaux, PR030/B or PR010/T).

On the page, only with Vaux, you can also see the state of the circuit breaker "STATUS", and thus make sure that the input is correctly wired.

The surfing path is summarized in the following table:

13.5.5.1 Test Menu table

Parameter / Function		Values	Notes
CB status		Open / Closed Indefinite	
Auto Test			
Trip Test		Enabled / Disabled	
PR120/D-M Module	State of springs Position of CB Open CB Closed CB	Loaded / Unloaded Isolated / Withdrawn	
PR120/K Module	Input Auto Test	ON ---	
Zone selectivity	Protection S (status) Input Force Output Release Output	ON/OFF	
	Protection G (status) Input Force Output Release Output	ON/OFF	

Model	L2234		Apparatus	Emax	Scale
			Doc.No.	1SDH000460R002	Page No. 69/155

13.5.6 Information Menu

The Information Menu enables you to view the data relating to the protection unit and the type of circuit breaker.

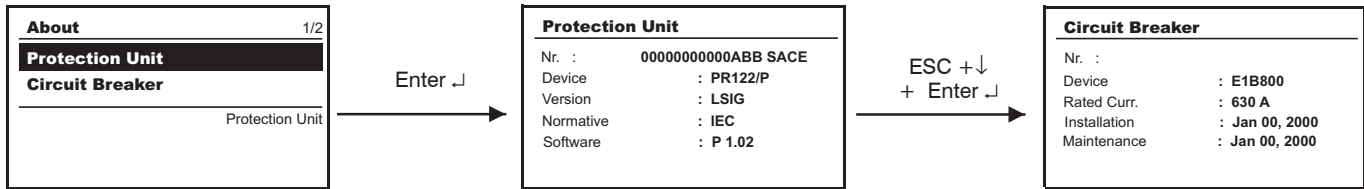

13.5.6.1 Information on the trip and opening data

The PR122/P unit saves all the information relating to the type of protection tripped, the opening data, the date and time. Using the "i Test" key makes the release show all these data directly on the display. There is no need for an auxiliary power supply for this function. With an auxiliary power supply, the information is shown immediately on the display without the need to press the "i Test" key and remains displayed indefinitely until you press the key.

The information remains available for 48 hours with the circuit breaker open or without any current flowing in the busbars. The data relating to the last 20 trips are stored in the unit's memory. By connecting a PR030/B battery unit or a BT030 wireless communication unit, you can retrieve the information relating to the last 20 trips recorded.

Access to view the opening data is via the Historicals submenu in the Measurements menu. The following is an example of the information provided:

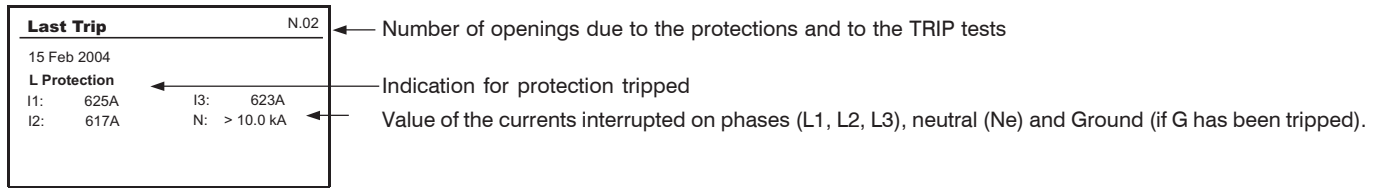

Again in the Measurements menu, you can view the percentage of contact wear, which is an indication of the electrical life of the electrical contacts in the circuit breaker.

In any case, functionality of the relay is in no way modified by the presence of the wear messages.

The prealarm message (wear > 80%, "warning" LED lighting up) indicates that the wear has reached a high value. The alarm message (100% wear, "alarm" LED lighting up) indicates that it is necessary to check the state of contact wear.

The percentage of wear depends on the number of openings carried out by the circuit-breaker and by the absolute current interrupted during each of them.

13.6 Definition of alarms and signals in the PR122/P unit

13.6.1 Optical signals

Signaling	Description
Warning (yellow) led	<ul style="list-style-type: none"> The prealarm threshold has been exceeded; one or more phases with current values in the range $0.9x_l < I < 1.05x_l$, (on the Ne it depends on the selection made; for instance, at 50% the values are halved) Presence, between two or three phases, of unbalance above the value programmed for the "U" protection, with protection trip disabled Presence of distorted wave form with form factor > 2.1; Contact wear greater than 80% (and less than 100%; with Vaux only); WARNING Threshold I_w exceeded; Circuit-breaker state error; Frequency out of range.
Alarm (red) led	<ul style="list-style-type: none"> Presence of overload on one or more phases with current values $I > 1.3 I_l$ (timing protection "L") (on the NE it depends on the selection made; for instance, at 200% the values are doubled)*; Timing in progress for protection function S; Timing in progress for protection function G; Timing in progress for the voltage (UV, OV, RV), frequency (OF, UF) protection functions; Timing in progress for the reverse active power protection function (RP); Timing in the case of unbalance between the phases (protection U) above the value set in the configuration with protection trip set to on; Contact wear = 100%; Rating Plug disconnected; Trip Coil (TC) disconnected. Key plug error Current sensors disconnected.

* The IEC 60947-2 Standard defines the timing threshold L for current: $1.05 < I < 1.3 I_l$

13.6.2 Electrical signals

K51/p1..p4 Programmable electrical signals, if the PR120/K module or the PR021/K unit are installed and there is an auxiliary power supply. Pressing the "i Test" key enables you to reset the activated contacts.

Model	L2234		Apparatus	Emax	Scale
			Doc.No.	1SDH000460R0002	Page No. 70/155











































13.6.3 Table of error and warning messages

All the messages which can be shown on the display relating to incorrect configurations, generic alarms or deriving from the protection functions and linked to useful information are described below.





The following symbols in the warning signals have the following meanings:

 = warning signal / Protection in alarm mode, with no trip (trip=off)

 = Protection in alarm mode, with trip at end of delay (trip=on)











Error message	Description	Notes
 Harmonic dist.	Harmonic distortion alarm	Busbar currents with form factor > 2.1
 Contact wear	Alarm for contact wear	Contact wear = 100%
 G	Alarm for protection G	
 Gext	Alarm for protection Gext	
 T Alarm	Alarm for protection T	Temperature outside range
 T	Alarm for protection T	
 U Alarm	Alarm for protection U	
 UV Alarm	Alarm for protection UV	
 OV Alarm	Alarm for protection OV	
 RV Alarm	Alarm for protection RV	
 RP Alarm	Alarm for protection RP	
 UF Alarm	Alarm for protection UF	
 OF Alarm	Alarm for protection OF	
 LC1 Load	Alarm for load control LC1	
 LC2 Load	Alarm for load control LC2	
 L1 Sensor	Alarm for L1 phase current sensor	Phase L1 sensor disconnected or faulty
 L2 Sensor	Alarm for L2 phase current sensor	Phase L2 sensor disconnected or faulty
 L3 Sensor	Alarm for L3 phase current sensor	Phase L3 sensor disconnected or faulty
 Ne Sensor	Alarm for Ne phase current sensor	Phase Ne sensor disconnected or faulty
 Gext Sensor	Alarm for Gext current sensor	Gext sensor disconnected or faulty
 Warning signal	Protection in alarm, with no trip (trip=off)	
 TC disconnected	Trip Coil disconnected or faulty	
 Rating Plug	Rating Plug Error absent or faulty	
 Power factor	Alarm for power factor	The power factor module is lower than the specified threshold
 Phase cycle	Phase cycle inverted	
 Invalid date	Clock information lost	
 CB status	CB state error	Probable error in Q26 and/or Q27
 Startup	Error during relay installation	
 CB not defined	State of circuit breaker inconsistent (Open/Closed)	Probable error in Q26 and/or Q27
 Local Bus	Local Bus error	See par. 13.7
 Contact wear	Contact wear prealarm	Contact wear ≥ 80%
 L prealarm	Protection L prealarm	
 T prealarm	Protection T prealarm	
 Frequency range	Error: frequency out of range	
 Warning lw	lw threshold exceeded	
 Timing L	Timing protection L	
 Timing S	Timing protection S	
 Timing G	Timing protection G	
 Timing Gext	Timing protection local Gext	
 Timing U	Timing protection U	
 Timing UV	Timing protection UV	
 Timing OV	Timing protection OV	

Model	L2234		Apparatus	Emax	Scale
			Doc.No.	1SDH000460R0002	Page No. 71/155

Error message	Description	Notes
 Timing RV	Timing protection RV	
 Timing RP	Timing protection RP	
 Timing UF	Timing protection UF	
 Timing OF	Timing protection OF	

13.6.4 Error messages displayed in pop-up windows

All the messages that appear on the display in a pop-up window are described below.

Error message	Description
 Password error	
 Session impossible	A programming session cannot be started due to a contingency (e.g. a timer-controlled delay still elapsing)
 Value outside range	Value beyond the established limits
 I2(S) <= I1(L)	Incongruence between thresholds of protections L and S
 NEC	NEC requirements not satisfied
 Unavailable	Function is not available
 Invalid date	Date has not been set
 Parameters revised	Programming session concluded correctly
 Cancelled	Programming session cancelled
 Failed	Programming session rejected



Model	L2234			Apparatus	Emax	Scale
				Doc.No.	1SDH000460R0002	Page No. 72/155

13.7 Troubleshooting PR122/P unit

The following table lists a series of typical service conditions, to help you understand and solve hypothetical faults or malfunctions.

Note:

1. Before consulting the following table, check for any error messages appearing for some seconds on the display.
2. FN indicates the normal operation of the PR122/P.
3. In the case where the suggestions proposed do not lead to a solution of the problem, please contact the ABB SACE assistance service.

N°	Situation	Possible causes	Suggestions
1	The trip test cannot be run	1. The busbar current is > 0. 2. The TC is not connected	1. FN 2. Check the messages on the display
2	Trip times lower than expected	1. Threshold too low 2. Curve too low 3. Thermal memory enabled 4. Incorrect Neutral Selection 5. The SdZ is inserted	1. Correct threshold 2. Correct curve 3. Exclude if not necessary 4. Correct neutral selection 5. Exclude if not necessary
3	Trip times higher than expected	1. Threshold too high 2. Curve too high 3. Curve I ² t inserted 4. Incorrect Neutral Selection	1. Correct threshold 2. Correct curve 3. Exclude if not necessary 4. Correct neutral selection
4	Rapid trip, with I3=Off	Inst tripped	FN with short-circuit with high I
5	High earth I, but no trip happens	1. Incorrect selection of the sensor 2. Function G prevented with I>4In	1. Set int. or ext. sensor 2. FN
6	Display off	1. Vaux missing and the current and/or voltages are below the minimum value. 2. Temperature out of range	1. FN, see 13.2.2.1 2. FN, see 13.2.9.8
7	The display is not back-lit	Current below the limit for lighting the display	FN
8	Reading of I incorrect	Current below the minimum threshold that can be displayed	FN
9	Reading of V, W and power factor incorrect	1) Connection error between VT and PR120/V 2) VT parameter settings error	1) Check connections between VT and PR120/V 2) Set the correct parameters
10	"  Local Bus" message on display	No communication between PR122/P and PR021/K	1. If not present, disable PR021/K, see 13.5.4.4.5 2. Check bus connection 3. Check PR021/K
11	Message "" instead of expected data	Function disabled or data out of range	FN
12	The expected trip does not occur	Trip function disabled	FN enable trip if necessary
13	No activation of the Unbalance U protection	Values of I out of range	FN, see 13.2.9.5
14	No display of the opening data	Vaux missing, the buffer capacitor is discharged	FN, see 13.5.6.1
15	The password is not requested	The password has been disabled	FN, re-enter the password with a value other than 0000.
16	Impossible to change any parameter	PR122/P in alarm situation	FN
17	"  Sensor time" or "  Start-up" message	Possible failure inside relay	Contact ABB Sace

13.7.1 In the case of a fault



If you suspect that the PR122/P is faulty, has a malfunction or has generated an unwanted trip, it is advisable to follow the recommendations below very carefully from the Measurements menu → Historicals → Trip:

1. Make a note of the type of protection that has tripped by accessing the LAST TRIP page if there is an external power supply (Vaux or battery) or by pressing "i Test" if in self-supply mode.
2. Note down the type of circuit-breaker, number of poles, any accessories connected, In, Serial Number (see par. 13.4) and the SW version.
3. Prepare a brief description of the opening (when did it happen?, how many times ?, was it always under the same conditions? what type of load? what voltage? what current? is the event reproducible?)
4. Send/communicate all the information collected, together with the circuit diagram for the circuit-breaker, to your nearest ABB Customer Support service.

The completeness and accuracy of the information given to the ABB Assistance service will facilitate technical analysis of the problem encountered, and will allow us to carry out all actions useful for the user rapidly.

Model	L2234		Apparatus	Emax	Scale
			Doc.No.	1SDH000460R0002	Page No. 73/155

13.8 Accessories

13.8.1 ABB SACE PR010/T test and configuration unit

The test with the SACE PR010/T unit enables you to check the proper operation of the inputs, outputs, thresholds and tripping times of the protection functions "L", "S", "I", "G", OV, UV, RV, U. The test unit is connected to the relay by means of the front Test connector (see par. 13.4).

13.8.2 ABB SACE PR030/B power supply unit

The PR030/B is a momentary power supply unit to be inserted in the front test connector of the PR122/P.

Using this standard accessory, you can run an autotest, the trip test, and power the PR122/P unit whatever the state of the circuit breaker (open/closed, in the test position or enabled and without an auxiliary power supply).

The battery inside the PR030/B guarantees a power supply to the unit for about 3h continuously (depending on the operations conducted on the PR122/P and on the PR120/D-BT module).

The life of the battery diminishes if the PR030/B accessory is also used to perform the trip test and the autotest. It is essential to use the PR030/B to read the trip data if the trip has occurred more than 48 hours earlier and the release was no longer powered.

13.8.3 BT030 wireless communication unit

The BT030 is a device for connecting to the Test connection on the PR122/P.

It enables Bluetooth communication between the protection release and a hand-held or laptop PC with a Bluetooth port.

This device is dedicated for use with the SD-Pocket application.

The BT030 has a rechargeable Li-ion battery that can provide the power needed for it to function and for the protection release.

Model	L2234			Apparatus	Emax	Scale
				Doc.No.	1SDH000460R0002	Page No. 74/155

14 SACE PR123/P Release - Identification

The PR123/P units available, in accordance with the IEC standards, together with the various protections and the various standard and optional modules, are illustrated in the following figure:

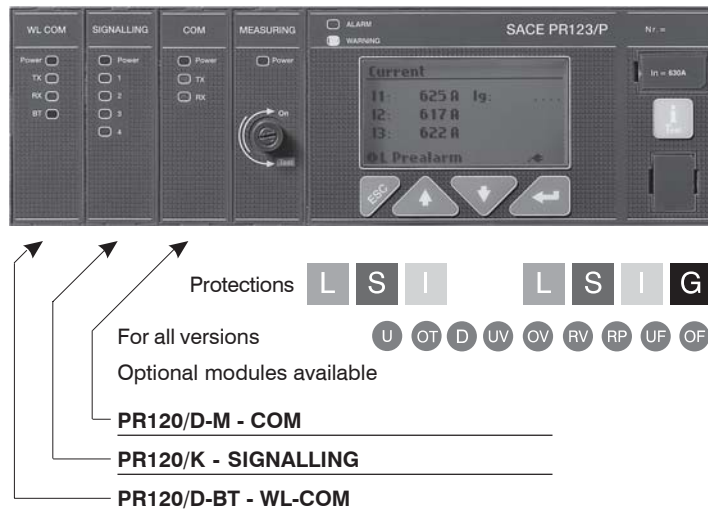

14.1 Standard

The PR123/P has been designed to work in accordance with the international standard: **IEC 60947-2 Low voltage apparatus. Circuit-breakers.**

14.2 Specifications

14.2.1 General

The PR123/P is a high-performance self-supplied protection unit with **Protection, Measurement, Data storage, Communication** (optional), **Self-test, Load control and Zone selectivity** functions for the ABB SACE 'Emax' range of 3- and 4-pole low-voltage air circuit breakers. The unit's user interface also enables parameter setup and completes the prealarm and alarm management for the protection and watchdog functions.

The protections available are:

Symbol	Protection against
L	overload with inverse long time delay
S, S2	short-circuit with adjustable delay
D	directional short-circuit with adjustable delay
I	instantaneous short-circuit
G	earth fault with adjustable delay
U	phase unbalance
OT	temperature out of range
UV	undervoltage
OV	overvoltage
RV	residual voltage
RP	reverse active power
UF	underfrequency
OF	overfrequency

The PR123/P can be installed on 3-pole CBs with and without an external neutral, or on 4-pole CBs.

It should be noted that the reference current for the PR123/P is the I_n (the rated current defined by the front Rating Plug) and not the I_u (the uninterrupted rated current of the CB itself).

Example: the CB E1B800 with a 400A Rating Plug has an I_u of 800A and an I_n of 400A

The unit opens the circuit breaker in which it is installed by means of the TC, which takes effect directly on the device's mechanical leverism.

The protection unit is self-supplied by current sensors and primary voltages via the PR120/V module.

The unit is made using digital microprocessor technology and interfaces with the user by means of a graphic display and keyboard.

Model	L2234		Apparatus	Emax	Scale
			Doc.No.	1SDH000460R002	Page No. 75/155

14.2.2 Electrical characteristics

Rated operating frequency	50/60 Hz ±10%
Pass band	3000 Hz max
Peak factor	6.3max @ 2 In
MTBF (MIL-HDBK-217E)	15 years @ 45°C

14.2.2.1 Self-supply

The self-supply enables the protection unit to be powered with the busbar current using current transformers. Using this supply mode, only the unit's protection functions are assured, however, not the accessory functions regarding the modules. The characteristics are given in the table below:

General characteristics	E1 - E2 - E3	E4 - E6
Minimum single-phase busbar current for enabling relay	70 A	140 A

14.2.2.2 Auxiliary power supply

The external auxiliary power supply is provided using a galvanically-separated power pack.



Since the auxiliary voltage needs to be isolated from the ground, "galvanically separated converters" in accordance with the IEC standard 60950 (UL 1950) or the equivalent IEC 60364-41 and CEI 64-8 have to be used to guarantee a current in common mode or leakage current (as defined in IEC 478/1 and CEI 22/3) no greater than 3.5mA

The presence of the auxiliary power supply enables the relay unit to be used even with the circuit breaker open, as well as powering all the modules, with the exception of the PR120/V - MEASURING module, which is powered by means of a connection to the busbars. The characteristics of the power pack are given in the table below:

Characteristics	Version PR123/P
Auxiliary voltage (galvanically separated)	24V DC ±20%
Maximum ripple	5%
Inrush current @ 24 V	~10A for 5ms
Rated power @ 24 V	~3W

14.2.2.3 Powered by the PR120/V module

For a full explanation of the features of the PR120/V, see par. 15.1.

14.2.3 Environmental characteristics

Operating temperature	-25°C ... +70°C
Storage temperature	-40°C ... +90°C
Relative humidity	0% ... 98% with condensation
Degree of protection (with PR123/P installed in the CB)	IP 30

14.2.4 Description of inputs/outputs

14.2.4.1 Binary opto-insulated inputs

- **K51/SZin (K51/DFin):** Zone selectivity: input for protection S or "direct" input for protection D (only with Vaux)
- **K51/Gzin (K51/DBin):** Zone selectivity: input for protection G or "reverse" direction input for protection D (only with Vaux)

14.2.4.2 Binary opto-insulated outputs

- **K51/SZout (K51/DFout):** Zone selectivity: output for protection S or "direct" output for protection D (only with Vaux)
- **K51/GZout (K51/DBout):** Zone selectivity: output for protection G or "reverse" output for protection D (only with Vaux)

14.2.5 Communication bus

Local internal bus on rear connector; RS485 physical interface, ABB SACE protocol
External system bus, RS485 physical interface, Modbus RTU protocol, baud rate 9600-19200 bps.

14.2.6 Protection functions

The PR123/P protection unit carries out 14 independent protection functions. In particular:

1. Protection against overload with inverse time "L";
2. Protection against short-circuit with adjustable delay "S" and "S2";
3. Protection against directional short-circuit with adjustable delay "D";
4. Protection against instantaneous short-circuit "I";
5. Protection against earth fault with adjustable delay "G";
6. Protection against instantaneous short circuit at high currents "I inst";
7. Protection against phase unbalance "U";
8. Protection against overtemperature "OT";
9. Protection against undervoltage "UV";

Model	L2234			Apparatus	Emax	Scale
				Doc.No.	1SDH000460R0002	Page No. 76/155

10. Protection against overvoltage "OV";
11. Protection against residual voltage "RV";
12. Protection against reverse active power "RP";
13. Underfrequency "UF";
14. Overfrequency "OF";

The PR123/P unit allows current signal processing of the neutral pole with different relationships relative to the value of the phases.
N.B.: Beyond 15.5xIn of current on the Ne, the protection is considered as being set to 100%.

A timing indication (message + "alarm" LED) is provided on the unit's display, which is activated during a protection alarm. It is disabled when the alarm condition ceases or when the protection has been tripped. When the circuit breaker opens, the page with the "Trip" data is displayed (when "i Test" is pressed, or automatically in the presence of Vaux).

14.2.6.1 Rms and peak calculation

All the protection functions do their respective processing on the basis of the real rms value of the currents and voltages (the protection G is disabled for current values greater than $8 I_n$ [where $0.5I_n \leq I_4 < 0.8I_n$], greater than $6I_n$ [where $I_4 < 0.5I_n$] and greater than $4I_n$ [where $I_4 < 0.5I_n$]). If the waveform has a deformation beyond the declared limit ($6.3@2 I_n$), the tolerance for the calculation of the true rms value will increase. The UV, OV, RV voltage protections always work on the basis of the true rms value of the voltages.

14.2.6.2 Mains frequency

The PR123/P unit constantly measures the frequency of the mains voltages it is connected to.

If the frequency goes out of the permitted range by $\pm 10\%$ in relation to the rated frequency selected (50 or 60Hz), the "warning" LED comes on and the warning message is displayed (see par. 14.6.3).

The signal can be combined with a relay of the optional PR120/K module or with those of the PR021/K unit.

14.2.6.3 Harmonic distortion

The PR123/P unit signals that a peak factor of 2.1 has been exceeded with a warning message and the "warning" LED lighting up (remember that the IEC 60947-2 standard annex "F" establishes that the protection unit must function regularly with a peak factor ≤ 2.1 , up to $2xI_n$).

The signal can be combined with a relay of the PR120/K module or with those of the PR021/K unit.

14.2.6.4 Circuit-breaker state

If an auxiliary supply is used, or it is powered from the optional PR120/V, the PR123/P unit records the state of the circuit breaker by means of specific wiring on the circuit breaker. In the case where the presence of current is determined with the circuit-breaker in the "OPEN" state, a state error is signaled by a warning message being displayed (see par. 14.6) and the "warning" LED lighting up.

The signal can be combined with a relay of the PR120/K module or with those of the PR021/K unit.

14.2.7 Measurement functions

The current measuring (ammeter) function is available on all versions of the SACE PR123/P unit.

The display shows histograms with the currents of the three phases and of the neutral on the main page. In addition, the current of the phase under the greatest load is given in numerical form. Where applicable, the earth fault current is displayed on a separate page.

The ammeter functions both in self-supply mode and with an auxiliary supply. In the latter case, the display is backlit and the ammeter is always active. The tolerance for the ammeter measuring chain (current sensor plus ammeter) is described in paragraph 14.2.9.16.

The PR123/P release provides a complete set of measurements:

- Currents: three phases (L1, L2, L3), neutral (Ne), earth fault
- Voltage: phase-phase, phase-neutral, residual voltage
- Instantaneous voltage values over a given time interval (data logger);
- Power: active, reactive, apparent
- Power factor
- Frequency and peak factor
- Energy: active, reactive, apparent, meter
- Harmonics calculation: up to the fortieth harmonic (waveform and module of the harmonics displayed); up to the thirty-fifth for frequency $f=60\text{Hz}$
- Maintenance: number of operations, percentage of contact wear, opening data storage.
- Data Logger: see par.16.4

The PR123/P can provide the trend of the measurements of certain quantities over an interval P, established by the user; these include: mean active power, maximum active power, maximum current, maximum voltage and minimum voltage. The last 24 P intervals (adjustable from 5 to 120 min) are stored in a non-volatile memory and displayed in a bar graph.

To examine the Measurement functions, see the relevant paragraphs (par. 15.1 and par. 14.5.3) for the PR120/V - MEASURING module.

14.2.8 Watchdog

The PR123/P unit provides some watchdog functions able to guarantee the proper management of relay malfunctions. These functions are as follows:

- Watchdog for presence of Auxiliary power supply with "plug" icon displayed.
- Rating PLUG validity.
- Watchdog for proper connection of the current sensors (CS). Any anomalies are indicated by a special alarm message and the "alarm" LED coming on, and the circuit breaker opens after 1s.

Model	L2234			Apparatus	Emax	Scale
				Doc.No.	1SDH000460R002	Page No. 77/155

- q Watchdog for proper connection of the trip coil (TC). Any anomalies are indicated by a special alarm message and the "alarm" LED coming on. If the PR120/D-M module is installed, this activates the coil opening command (YO), thus opening the CB.
- q Watchdog for protection of Hw Trip. In the event of the sensors being disconnected or a Rating Plug error, a CB opening command is given by the TC being enabled.

14.2.9 Description of the protection functions

14.2.9.1 Protection "L"

The "L" is the only protection that cannot be disabled because it is for self-protection against overloading of the relay itself. The types of trip curves settable are divided into two groups according to the standard they refer to.

Standard trip curve according to IEC 60947-2

Only one type of curve is settable ($t=k/I^2$) as defined by the IEC standard 60947-2
The protection trip time - inverse time - is given by the expression

$$\frac{9 \cdot t_f}{(I_f/I_1)^2} \quad \text{where } I_f \leq 12I_n \text{ and } 1 \text{ s where } I_f > 12I_n \quad \text{where } I_f \text{ is the fault current and } I_1 \text{ the protection threshold.}$$

NB: Time expressed in seconds.

Standard trip curve according to IEC 60255-3

There are 3 types of curves settable, defined by the IEC standard 60255-3 as A, B and C.
The protection trip time - inverse time - is given by the expression

$$t = \frac{k}{(I)^a - 1} \cdot b \quad \text{where } I = \frac{I_f}{I_1} \quad I_f \text{ is the fault current and } I_1 \text{ the protection threshold specified by the user.}$$

NB: Time expressed in seconds.

a and k are two parameters, suggested by the standard, which vary the type of slope selected (e.g. for type B slope a = 1 and k = 13.5);
b is a parameter introduced by SACE to increase the number of curves with the same slope.

4.2.9.1.1 Thermal memory "L"

The thermal memory function can be enabled for cable protection. It is based on the "tL" parameter defined as the trip time of the curve (t1) selected at 1.25xI1. The release trip time is certainly 100% of the one selected, after an interval tL has passed since the last overload or since the last trip. Otherwise, the trip time will be reduced, depending on the overload which has occurred and on the time that has elapsed.

The PR123/P is fitted with two instruments to make up this thermal memory. The first is only effective when the release is powered (it also records overloads that have not lasted long enough to trip the release), while the second works even when the release is not powered, reducing any trip times in the case of an immediate reclosing and is enabled as soon as the CB is tripped.

It is the PR123/P release that automatically decides which of the two to use, according to the various situations.

N.B.: The thermal memory function can only be set if the type of curve selected is the standard one ($t=k/I^2$) (see par. 14.2.9.1).

14.2.9.2 Protection "S"

This protection can be disabled; it can be of the fixed time ($t=k$) or inverse time ($t=k/I^2$) type. In the latter case, the trip time is given by the expression

$$\max \left[\frac{100 \cdot t_2}{(I_f)^2}, t_2 \right] \quad \text{for } I_f > I_2 \quad \text{where } I_f \text{ is the fault current and } I_2 \text{ the protection threshold.}$$

14.2.9.2.1 Thermal memory "S"

The thermal memory function can be enabled for cable protection in the case where the curve with inverse time is selected. This is based on the "tS" parameter defined as the trip time of the curve (t2) selected at 1.5xI2. The other characteristics are the same as those for thermal memory "L" (see par. 14.2.9.1.1).

14.2.9.2.2 Start-up threshold "S"

The start-up function can be selected in the case where the curve with fixed time is selected.

The function can be disabled and it is a setting characteristic of the single protection units.

The start-up function enables the protection threshold (S, D, I and G) to be changed during a time interval lasting "ts", starting from "start-up". The latter must be intended as follows:

- Turning on of the relay, under self-supply;
- Passage of the peak value of the maximum current over 0.1xIn. A new start-up is possible after the current has dropped below 0.1xIn.

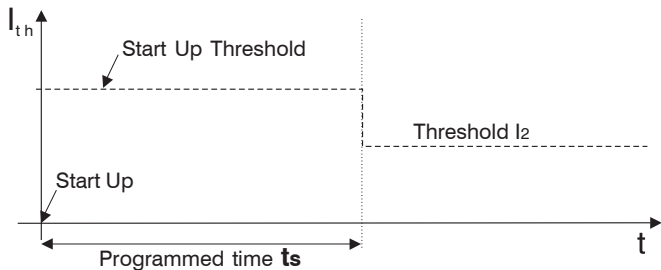

• Start-up time

The start-up time is common to all the protections involved.

Range: 0.1 s ... 1.5 s, with steps of 0.01 s.

Model	L2234			Apparatus	Emax	Scale
				Doc.No.	1SDH000460R0002	Page No. 78/155

14.2.9.2.3 Zone selectivity "S"

The zone selectivity function, guaranteed only if an auxiliary voltage is provided, enables the area of the fault to be isolated, only isolating the part of plant nearest to the fault, while keeping the rest of the plant operational.

This is done by connecting all the zone selectivity outputs of the releases belonging to the same zone to one another (ZSO=K51/SZout) and taking this signal to the zone selectivity input (ZSI=K51/SZin) of the next release on the supply side. If the wiring has been done correctly, all the zone selectivity inputs of the last circuit-breakers in the chain and all the outputs of the circuit-breakers at the head of each chain must be empty.

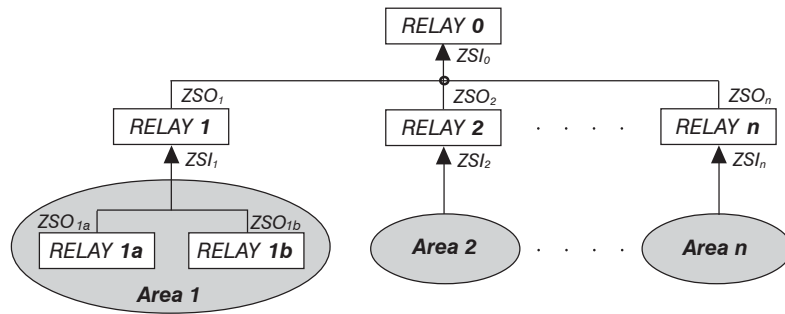

As a practical example, the figure above shows a fault on the load side of the "Relay 1a" isolated by the latter without the "Relay 1" or the "Relay 0" being affected; a fault immediately downstream from the "Relay 1" will be isolated by the latter without the "Relay 0" being affected, thus ensuring that the Areas 2...n remain operational.

The ZSO output can be connected to a maximum of 20 ZSI relays on the supply side in the selectivity chain.



The maximum length of cable for zone selectivity, between two units, is 300 meters. Use corded shielded two-wire cable (see note A to par. 11.2.2). The shield must only be earthed on the circuit-breaker of the supply-side relay (ZSI side).

Wiring and enabling zone selectivity "S" is an alternative to using protection "D" and operation is only guaranteed when there is an auxiliary voltage. The following logical table is implemented to manage the Zone Selectivity Input (ZSI) and Zone Selectivity Output (ZSO) signals:

Zone selectivity	$I_{max} > I_2$	ZSI signal	ZSO signal	Trip T
Excluded	NO	0	0	No trip
Excluded	NO	1	0	No trip
Excluded	YES	0	0	t_2 programmed
Excluded	YES	1	0	t_2 programmed
Inserted	NO	0	0	No trip
Inserted	NO	1	1	No trip
Inserted	YES	0	1	$t_{selectivity}$
Inserted	YES	1	1	t_2 programmed

The time t_2 must be set at a value corresponding to at least $t_{selectivity} + 50$ ms.

14.2.9.3 Double S

Thanks to the new PR123/P release that enables two independent and simultaneously active protection S thresholds to be specified, selectivity can assured even in critical conditions.

This function enables a better selectivity level to be obtained than using a release without a "double S".

14.2.9.4 Directional Protection "D"

The PR123/P unit carries out excludable directional protection against short-circuit with adjustable fixed time ($t = k$) active both with self-supply and with auxiliary supply.

The protection functionality is very similar to protection "S" with fixed time, with the capacity to recognize the current direction during the fault period as well. However, it is a phase and not a neutral protection.

The direction of the current enables the determination of whether the fault is on the supply side or the load side of the circuit-breaker. Especially in ring distribution systems, this enables the distribution stretch where the fault occurred to be identified and isolated without interfering with the rest of the installation (using zone selectivity).

To determine the direction of the current, the value of the phase reactive powers has to be higher than 2% of the nominal phase power

$$(P_Q \geq 2\% \cdot P_{nphase}).$$

Protection D always considers I neutral = 100%.

The PR123 enables you to define the power flow in the circuit breaker from the menu from high to low (High → Low), from low to high (Low → High), selectable in the menu Modules Measuring Module (PR120/V).

Model	L2234			Apparatus	Emax	Scale
				Doc.No.	1SDH000460R002	Page No. 79/155

As a result, the currents in the circuit breaker will be defined as "forward" or "backward" if their are in phase or out of phase with the previously-defined power flow (for the default setting, see par.14.4.4).

In short:

Ifault (I_f)		Power flow setting High -> Low	Power flow setting Low -> High
Value	Direction	T trip	T trip
$I_f < I_r$	either	No trip	No trip
$I_f > I_r$	High → Low	t_{7FW}	t_{7BW}
$I_f > I_r$	Low → High	t_{7BW}	t_{7FW}

Example:

Once the power flow has been set as "High → Low", the direction of the figure alongside is:

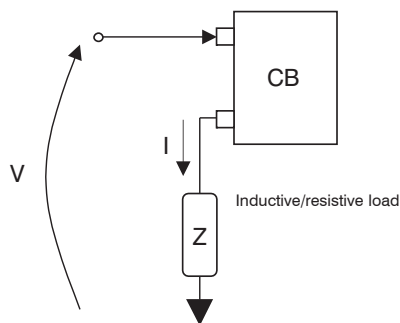

positive reactive power in → "forward" direction;

negative reactive power in → "backward" direction;

If the preset trip times were $t_{7FW} = 200\text{ms}$ and $t_{7BW} = 400\text{ms}$, in this case the relay would have opened the circuit breaker after $t_{7FW} = 200\text{ms}$.

In short:

If $I_f > I_r$ and the direction of the current detected is in phase, at the power flow set by the user the relay counts down the delay and opens the circuit breaker in a time corresponding to t_{7FW} .

If $I_f > I_r$ and the direction of the current detected is out of phase, at the power flow set by the user the relay counts down the delay and opens the circuit breaker in a time corresponding to t_{7BW} .

Note:

- With the directional protection D activated, if the direction of the power cannot be determined the relay takes effect considering shorter of the programmed times between t_{7fw} and t_{7bw} .
- This protection works on the basis of the phase currents, not the neutral current.

14.2.9.4.1 Start-up threshold "D"

The function can be enabled from the menu (see description of the protection menu 14.5.2)

The function behaves in exactly the same way as the protection "S" (see par. 14.2.9.2.2).

14.2.9.4.2 "D" (directional) zone selectivity

The Directional Zone Selectivity (SdZ D) function is particularly useful in ring and grid type systems where, in addition to the zone, it is essential to define the direction of the power flow that powers the fault.

The SdZ D can be set as an alternative to Zone Selectivity S and G and requires an auxiliary power supply.

To define the zone and power flow, each relay has two inputs (DFin and DBin) and two outputs (Dfout and DBout), which must be suitably connected to the other relays (see example below).

As in the SdZ S and G, the relays interact with each other, sending cutout signals via the outputs and reading them via the inputs.

The general behavior is summarized in the table below.

(Example with power flow setting "High → Low").

Ifault (I_f)		Outputs status		Inputs status		T trip
Value	Direction	DFout	DBout	DFin	DBin	
$I_f < I_r$	either	0	0	either	either	No trip
$I_f > I_r$	High -> Low	1	0	0	either	t_s
$I_f > I_r$	High -> Low	1	0	1	either	t_{7FW}
$I_f > I_r$	Low-> High	0	1	either	1	t_{7BW}
$I_f > I_r$	Low-> High	0	1	either	0	t_s

Model	L2234			Apparatus	Emax	Scale
				Doc.No.	1SDH000460R0002	Page No. 80/155

If the power flow is in phase with the direction set on the relay, the output DFout is enabled (1).
 Vice versa, if the power flow is out of phase, the output DBout is enabled (1).

The typical configuration of the system of circuit breakers for which the SdZ D is likely to be used is the sort of ring illustrated in the following figure

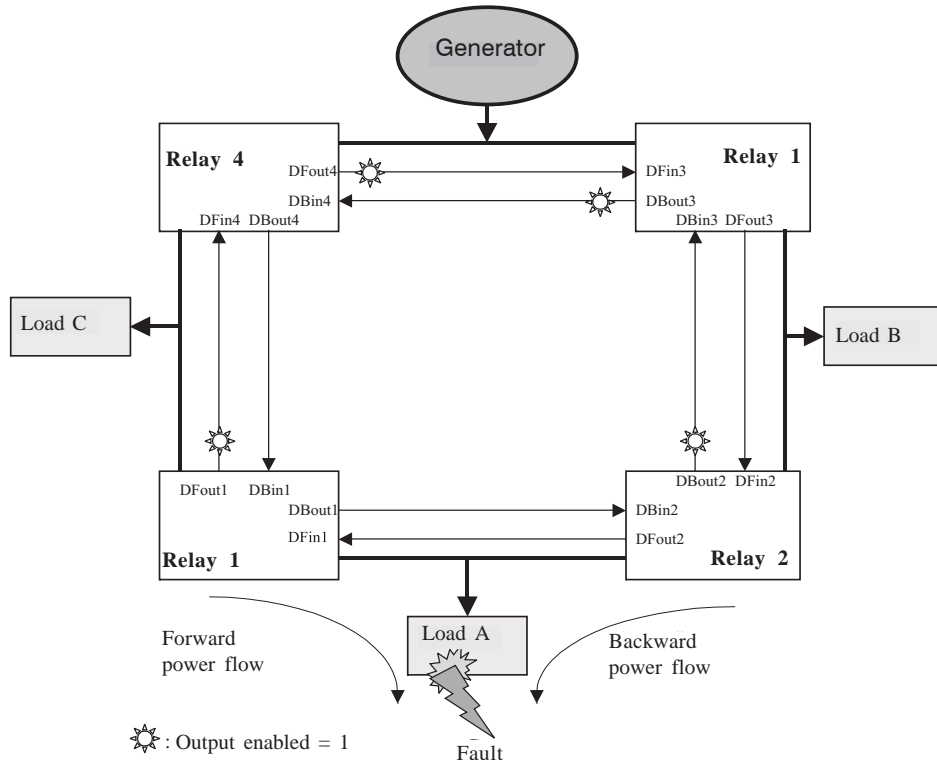

If a fault is detected (I fault I_f beyond the threshold I_T) one of the sections in the system (Load A), the final circuit breakers for the section in question (Relay1 and Relay2) communicate the presence of the fault to the connected circuit breakers (Relay4 and Relay3) by setting the output signals DFout or DBout depending on the direction of the current (DFout1=On, DBout=On). To be more precise, the circuit breakers that limit the section affected by the fault see the direction of the fault current in different ways (Relay1=forward and Relay2=backward).

The circuit breakers (Relay1 and Relay2) delimiting the section affected by the fault are tripped with the selectivity time t_s, while the circuit breakers further away from the fault count down the time t_{7FW} (Relay4) and t_{7BW} (Relay3) without opening; in this way, the system is isolated, in the time t_s, to exclude the part affected by the fault.

The load A, where the fault has occurred, will be disconnected, but loads B and C will continue to be powered normally.

It should be noted that activation of the DBout3 output by the relay3 will have no effect on the relay4, because the latter is recording not an out-of-phase (backward) fault current, but an in-phase (forward) current with the power flow defined previously by the user (High -> Low).

Note:

- With zone selectivity enabled, if the direction of the power flow cannot be ascertained, the relay is tripped considering the lesser of the programmed times between t_{7fw} and t_{7bw}, without enabling any outputs (DFout or DBout).
- If, for some reason, one of the circuit breakers required to open does not do so, a specific function will activate the opening of the first circuit breaker immediately upstream from it, after a further 100 ms approx. In the above example, if the circuit breaker does not open with the relay1, only the circuit breaker with relay4 will open after a time t_s+100 ms.
- The SdZ D operates on the basis of the phase currents, not of the neutral.

14.2.9.5 Protection "I"

The protection is enabled/disabled from the menu.

In the case where zone selectivity "S" (or "D") is active, during the trip of the relay for "I", the ZSO (or DFW and BFW) output signal is activated in any case to guarantee correct operation of the relay on the supply side (and on the load side).

14.2.9.5.1 Start-up threshold "I"

The start-up function can be selected.

The function can be enabled from the menu on the protection "I" page.

The function behaves in exactly the same way as the protection "S" (see par. 14.2.9.2.2).

14.2.9.6 Protection "G"

This protection can be disabled; it can be of the fixed time (t=k) or inverse time (t=k/i²) type. In the latter case, the trip time is given by the expression

$$\max \left(\frac{2}{I^2}, t_4 \right) \text{ where } I = I_f / I_4, I_f \text{ is the fault current and } I_4 \text{ is the protection threshold.}$$

NB: Time expressed in seconds.



It is possible to disable the trip control of the protection ("EnableTrip: Off").

For the whole duration of the earth fault, circuit-breaker opening does not take place, but only the alarm condition is signaled ("Alarm" LED lit and alarm message).

Model	L2234		Apparatus	Emax	Scale
			Doc.No.	1SDH000460R002	Page No. 81/155

The PR123/P unit can provide two different types of earth fault protection:

Internal protection G

This is provided inside the release by vectorially summing the phase and neutral currents. The fault current is defined by the following formula:

$$\vec{I}_G = \vec{I}_1 + \vec{I}_2 + \vec{I}_3 + \vec{I}_N$$

In the case when the circuit does not show any fault, the module of the sum of these currents is always nil; vice versa the value of the fault current will take on an increasingly large value depending on the size of the fault. This operating mode is enabled by default.

N.B.: it can be used also with CS for an external neutral.

Protection G with external toroid "Source Ground Return"

Also called "Source Ground return", this can be carried out when there is the need to check operation of a machine (transformer, generator or motor etc.) which has star-configured windings.

The protection is assured by physically positioning an external toroid on the cable connected from the star center of the machine to the earthing connection point.

The induced current on the winding of the toroid is proportional to the fault current which, in this case, only transits in the above-mentioned toroid. To work in this mode, "Ground protection" must be selected on the Circuit breaker Settings menu.



The external toroid must be connected to the PR123/P by means of a corded shielded two-wire cable (see note A in par. 11.2.2) with a length not exceeding 15m. The shield must be earthed both on the circuit-breaker side and on the toroid side.

It is indispensable for the star center to be connected openly to earth and for it not to be used as a neutral conductor too (as in the TNC system), making a protection according to the TT system.

The protections G and Gext can be enabled simultaneously.

14.2.9.6.1 Start-up threshold "G"

The start-up function can be selected in the case where the curve with fixed time is selected.

The function can be enabled and disabled on the protection "G" page.

The function behaves in exactly the same way as the protection "S" (see par. 14.2.9.2.2).

14.2.9.6.2 Zone selectivity "G"

The zone selectivity function can be enabled providing the fixed time curve, the wiring and the zone selectivity "G" enabling alternative to the one for "D" have been selected and the function is assured only if auxiliary voltage is provided.

Zone selectivity "G" can be active at the same time as zone selectivity "S".

The behavior and wiring of the function are identical to those indicated for zone selectivity "S" (see par. 14.2.9.2.3).

14.2.9.7 Protection against phase unbalance "U"

The protection with fixed time, which can be excluded, trips in the case when, for a time greater than or the same as the time **t6** set, an unbalance is determined between two or more phases higher than the set threshold **I6**.

The percentage of unbalance is therefore calculated $\%_{unb} = \frac{I_{max} - I_{min}}{I_{max}} \cdot 100$ where I_{max} is the maximum and I_{min} is the minimum phase current.



It is possible to disable the trip control of the protection ("EnableTrip: Off"). In that case, for the whole duration of the unbalance the CB will not be opened, but only the condition will be signaled by means of the "warning" LED lit up and a warning message. When the value of the phase current is above a $6xI_n$, the function "U" excludes itself because, in this case, the other protections intervene because the fault is considered as a phase fault. The protection is not enabled for maximum phase current values lower than $0.3xI_n$.

14.2.9.8 Protection against overtemperature inside the relay, "OT"

There is a sensor inside the PR123/P unit that monitors the temperature of the unit.

This enables the signalling of any abnormal temperature conditions, which could cause temporary or continuous malfunctions of the unit's electronic components.

This protection has two states of operation:

State of "WARNING TEMPERATURE" with the "WARNING" LED flashes

-25°C < temp. < -20°C

or

70°C < temp. < 85°C

: the display is turned off and

State of "ALARM TEMPERATURE" with

temp. < -25°C

or

temp. > 85°C

: the display is turned off,

the "WARNING" led remains on and the Trip is activated (if enabled by means of the "Over Temper. Trip = On" parameter).

N.B.:

- In the event of Warning and Alarm, the display is momentarily turned off, to preserve its functionality.
- The monitored temperature is not visible on the display.

The protection is always active, both with auxiliary supply and in self-supply.



Disabling the Trip control of the protection means that the PR123/P unit could work, with the circuit-breaker closed, in a range of temperatures where correct operation of the electronics is not guaranteed.

Model	L2234			Apparatus	Emax	Scale
				Doc.No.	1SDH000460R0002	Page No. 82/155

14.2.9.9 Load control function

Single loads can be enabled/disabled on the load side before the overload protection L intervenes and trips the circuit breaker on the supply side. This is done by contactors or switch-disconnectors (wired outside the release), controlled by the PR123/P by means of contacts on the PR120/K module or on the PR021/K external unit.

The current thresholds are lower than those available with the protection L, so that the load control can be used to prevent tripping due to overloads. The function is active when an auxiliary power supply or power by PR120/V module is present (see par.15.1.4). The operating logic involves the activation of three contacts when the preset thresholds LC1, LC2 and I_w are exceeded. Thresholds LC1 and LC2 are expressed as a percentage of I_l (current threshold specified for protection L) while the "warning current" I_w is expressed as an absolute value. The allowable values are given in the following table:

Warning current I_w	0.30 ÷ 3.00 step 0.05x I_n
Threshold LC1	50% ÷ 100% step 1% x I_l
Threshold LC2	50% ÷ 100% step 1% x I_l

From the PR123/P you can associate each of the PR120/K or PR121/K contacts with a configuration (NO or NC), a delay and any latch.

14.2.9.10 Voltage protections "UV", "OV", "RV"

The PR123/P unit provides 3 voltage protections, which can be disabled, with fixed adjustable time ($t = k$), active both with self-supply and with auxiliary supply:

- Undervoltage "UV"
- Overvoltage "OV"
- Residual voltage "RV"

The protections work on the voltages. The threshold voltages indicated refer to the line voltage.

Apart from the normal timing and "TRIP" operation, the voltage protections can be in a state defined as "alarm" (with the "emergency" led on and an alarm message displayed) providing there is an auxiliary or PR120/V module power supply. In fact, in the case where the circuit-breaker is open and no current is detected, the timing leads to the "alarm" state and not to "TRIP". This is because the fault linked to the voltages can persist even with the circuit-breaker open and the unit would therefore always be under "timing". When the circuit-breaker is closed or the passage of a current is detected, you pass immediately from the state of "alarm" to "TRIP" without timing (for warning see par. 14.3.2).

14.2.9.10.1 Protection "UV"

When the minimum phase voltage drops below the set threshold U_g the protection counts down the preset time interval t_g and then opens.

14.2.9.10.2 Protection "OV"

When the maximum phase voltage exceeds the set threshold U_g the protection counts down the preset time interval t_g and then opens.

14.2.9.10.3 Protection "RV"

When the residual voltage exceeds the set threshold U_0 the protection counts down the preset time interval t_0 and then opens. The residual voltage U_0 is calculated by vectorially summing the phase voltages. It is therefore defined by the following formula

$$\vec{U}_0 = \vec{U}_1 + \vec{U}_2 + \vec{U}_3$$

14.2.9.11 Protection against Reverse active power "RP"

The PR123/P unit provides protection (which can be disabled) with an adjustable fixed time ($t = k$), against reverse active power, active both with self-supply and auxiliary supply.

When the total reverse active power (sum of the power of the 3 phases) exceeds the set reverse active power threshold P_{11} , the protection counts down the preset time interval t_{11} and then opens.

The minus sign ("-") in front of the threshold and power indicates reverse power. The threshold is indicated as a percentage of "Pn", where "Pn" is the nominal power of the circuit-breaker ($3 \sqrt{3} V_n I_n$).

14.2.9.12 Frequency protections "UF", "OF"

The frequency protections record the mains frequency variations above an adjustable threshold (f_{12}, t_{12}) or below (f_{13}, t_{13}), generating an alarm or the opening of the circuit breaker.

14.2.9.13 Double protections setting

Using the double protections setting, the PR123/P can save a set of alternative parameters for all the protections. The second set of parameters (set B) can replace the default set (set A) by means of an external command. The passage from set A to set B can be made when there is a change in the mains configuration or when there is an emergency capable of changing the load capacity and the short circuit levels.

The second set of parameters (set B) can be enabled by:

- digital input provided with the PR120/K module. For instance, it can be connected to an auxiliary contact of a bus-tie;
- communication network, by means of the PR120/D-M (e.g. when the switch is scheduled);
- directly from the user interface on the PR123/P (see settings menu par. 14.5.4).
- with a time that can be specified by set A or set B after the circuit breaker has closed.

In operation, the state (set A and set B) is indicated on the display.

The double setting is disabled by default. To enable it, see par. 14.5.1.4.

Model	L2234		Apparatus	Emax	Scale
			Doc.No.	1SDH000460R0002	Page No. 83/155

14.2.9.14 Summary table of the protection function settings for the PR123/P

Protection	Disabling	Disabling of TRIP only	Zone selectivity	Start-up threshold	Thermal memory	Threshold Range	Time Range	Tolerance threshold ⁽²⁾	Time Tolerance ⁽²⁾
L ($t=k/l^2$) curve IEC60255-3	<input type="checkbox"/>	<input type="checkbox"/>	<input type="checkbox"/>	<input type="checkbox"/>	<input checked="" type="checkbox"/>	$0.4xI_n \leq I_1 \leq 1xI_n$ step $0.01xI_n$	$3s \leq t_1 \leq 144s^{(1)}$, step $3s$ at $I=3xI_1$	Release between 1.05 and $1.2xI_1$	$\pm 10\%$, $I_1 \leq 6 In$ $\pm 20\%$, $I_1 > 6 In$
S₁ ($t=k$)	<input checked="" type="checkbox"/>	<input type="checkbox"/>	<input checked="" type="checkbox"/>	<input checked="" type="checkbox"/>	<input type="checkbox"/>	$0.6xI_n \leq I_2 \leq 10xI_n$ step $0.1xI_n$ $0.6xI_n \leq I_{2\text{ start-up}} \leq 10xI_n$ step $0.1xI_n$	Min, $0.05s \leq t_2 \leq 0.8s$, step $0.01s$ $0.10s \leq t_{2\text{ start-up}} \leq 1.5s$, step $0.01s$ $0.04s \leq t_{2\text{ sel}} \leq 0.20s$, step $0.01s$	$\pm 7\%$, $I_1 \leq 6 In$ $\pm 10\%$, $I_1 > 6 In$	The best of the two data $\pm 10\%$ or $40 ms$
S₁ ($t=k/l^2$)	<input checked="" type="checkbox"/>	<input type="checkbox"/>	<input type="checkbox"/>	<input type="checkbox"/>	<input checked="" type="checkbox"/>	$0.6xI_n \leq I_2 \leq 10xI_n$ step $0.1xI_n$	$0.05s \leq t_2 \leq 0.8s$, step 0.01 at $10xI_n$	$\pm 7\%$, $I_1 \leq 6 In$ $\pm 10\%$, $I_1 > 6 In$	$\pm 15\%$, $I_1 \leq 6 In$ $\pm 20\%$, $I_1 > 6 In$
S₂ ($t=k$)	<input checked="" type="checkbox"/>	<input type="checkbox"/>	<input checked="" type="checkbox"/>	<input checked="" type="checkbox"/>	<input type="checkbox"/>	$0.6xI_n \leq I_2 \leq 10xI_n$ step $0.1xI_n$	Min, $0.05s \leq t_2 \leq 0.8s$, step $0.01s$ $0.10s \leq t_{2\text{ start-up}} \leq 1.5s$, step $0.01s$ $0.04s \leq t_{2\text{ sel}} \leq 0.40s$, step $0.005s$	$\pm 7\%$, $I_1 \leq 6 In$ $\pm 10\%$, $I_1 > 6 In$	The best of the two data $\pm 10\%$ or $40 ms$
D ($t=k$)	<input checked="" type="checkbox"/>	<input type="checkbox"/>	<input checked="" type="checkbox"/>	<input checked="" type="checkbox"/>	<input type="checkbox"/>	$0.6xI_n \leq I_7 \leq 10xI_n$ step $0.1xI_n$	$0.20s \leq t_7 \leq 0.8s$, step $0.01s$ $0.10s \leq t_{7\text{ start-up}} \leq 1.5s$, step $0.01s$ $0.13s \leq t_{7\text{ sel}} \leq 0.50s$, step $0.01s$	$\pm 10\%$	The best of the two data $\pm 10\%$ or $40 ms$
I ($t=k$)	<input checked="" type="checkbox"/>	<input type="checkbox"/>	<input type="checkbox"/>	<input checked="" type="checkbox"/>	<input type="checkbox"/>	$1.5xI_n \leq I_3 \leq 15xI_n$ step $0.1xI_n$	$\leq 30 ms$	$\pm 10\%$	
G⁽⁴⁾ ($t=k$)	<input checked="" type="checkbox"/>	<input checked="" type="checkbox"/>	<input checked="" type="checkbox"/>	<input checked="" type="checkbox"/>	<input type="checkbox"/>	$0.20xI_n \leq I_4 \leq 1xI_n$ step $0.02xI_n$	$0.1s \leq t_4 \leq 1s$, step $0.05s$ $0.2s \leq t_{4\text{ start-up}} \leq 1s$, step $0.02s$ $0.04s \leq t_{4\text{ sel}} \leq 0.2s$, step $0.01s$	$\pm 7\%$	The best of the two data $\pm 10\%$ or $40 ms$
G⁽⁴⁾ ($t=k/l^2$)	<input checked="" type="checkbox"/>	<input checked="" type="checkbox"/>	<input type="checkbox"/>	<input type="checkbox"/>	<input type="checkbox"/>	$0.2xI_n \leq I_4 \leq 1xI_n$ step $0.02xI_n$	$0.1s \leq t_4 \leq 1s$, step $0.05s$	$\pm 7\%$	$\pm 15\%$
Gext ($t=k$)	<input checked="" type="checkbox"/>	<input checked="" type="checkbox"/>	<input checked="" type="checkbox"/>	<input checked="" type="checkbox"/>	<input type="checkbox"/>	$0.2xI_n \leq I_4 \leq 1xI_n$ step $0.02xI_n$	$0.1s \leq t_4 \leq 1s$, step $0.05s$ $0.2s \leq t_{4\text{ start-up}} \leq 1s$, step $0.02s$ $0.04s \leq t_{4\text{ sel}} \leq 0.2s$, step $0.01s$	$\pm 7\%$	The best of the two data $\pm 10\%$ or $40 ms$
Gext ($t=k/l^2$)	<input checked="" type="checkbox"/>	<input checked="" type="checkbox"/>	<input type="checkbox"/>	<input type="checkbox"/>	<input type="checkbox"/>	$0.2xI_n \leq I_4 \leq 1xI_n$ step $0.02xI_n$	$0.1s \leq t_4 \leq 1s$, step $0.05s$	$\pm 7\%$	$\pm 15\%$
Gext (I_{dn})	<input checked="" type="checkbox"/>	<input checked="" type="checkbox"/>	<input type="checkbox"/>	<input type="checkbox"/>	<input type="checkbox"/>	$I_{dn} = 0.3-0.5-0.7-1.0$ $2.0-3.0-5.0-7.0-10-20$ $30A$	$0.06-0.10-0.20-0.30-0.40-0.50$ $0.80-1.00-3.00-4.8s^{(3)}$	$\pm 10\%$	
U ($t=k$)	<input checked="" type="checkbox"/>	<input checked="" type="checkbox"/>	<input type="checkbox"/>	<input type="checkbox"/>	<input type="checkbox"/>	$5\% \leq I_5 \leq 90\%$ step 5%	$0.5s \leq t_5 \leq 60s$, step $0.5s$	$\pm 10\%$	The best of the two data $\pm 10\%$ or $40 ms$
OT ($temp=k$)	<input type="checkbox"/>	<input checked="" type="checkbox"/>	<input type="checkbox"/>	<input type="checkbox"/>	<input type="checkbox"/>	fixed, defined by SACE	Instantaneous	$\pm 1^\circ C$	-----
Iinst	<input type="checkbox"/>	<input type="checkbox"/>	<input type="checkbox"/>	<input type="checkbox"/>	<input type="checkbox"/>	Automatic, defined by SACE	Instantaneous	$\pm 5\%$	+1mS
UV ($t=k$)	<input checked="" type="checkbox"/>	<input checked="" type="checkbox"/>	<input type="checkbox"/>	<input type="checkbox"/>	<input type="checkbox"/>	$0.5xU_n \leq U \leq 0.95xU_n$ step $0.01xU_n$	$0.1s \leq t_8 \leq 5s$, step $0.1s$	$\pm 5\%$	$\pm 20\%$
OV ($t=k$)	<input checked="" type="checkbox"/>	<input checked="" type="checkbox"/>	<input type="checkbox"/>	<input type="checkbox"/>	<input type="checkbox"/>	$1.05xU_n \leq I_9 \leq 1.2xU_n$ step $0.01xU_n$	$0.1s \leq t_9 \leq 5s$, step $0.1s$	$\pm 5\%$	The best of the two data $\pm 10\%$ or $40 ms$
RV ($t=k$)	<input checked="" type="checkbox"/>	<input checked="" type="checkbox"/>	<input type="checkbox"/>	<input type="checkbox"/>	<input type="checkbox"/>	$0.1xU_n \leq I_{10} \leq 0.4xU_n$ step $0.05 U_n$	$0.5s \leq t_{10} \leq 30s$, step $0.5s$	$\pm 5\%$	The best of the two data $\pm 10\%$ or $40 ms$
RP ($t=k$)	<input checked="" type="checkbox"/>	<input checked="" type="checkbox"/>	<input type="checkbox"/>	<input type="checkbox"/>	<input type="checkbox"/>	$-0.3xP_n \leq P_{11} \leq -0.1xP_n$ step $0.02 P_n$	$0.5s \leq t_{11} \leq 25s$, step $0.1s$	$\pm 10\%$	The best of the two data $\pm 10\%$ or $40 ms$
UF	<input checked="" type="checkbox"/>	<input checked="" type="checkbox"/>	<input type="checkbox"/>	<input type="checkbox"/>	<input type="checkbox"/>	$0.9fn \leq f \leq 0.99fn$ step $0.01 fn$	$0.5s \leq t_{12} \leq 3s$, step $0.1s$	$\pm 5\%$	The best of the two data $\pm 10\%$ or $40 ms$
OF	<input checked="" type="checkbox"/>	<input checked="" type="checkbox"/>	<input type="checkbox"/>	<input type="checkbox"/>	<input type="checkbox"/>	$1.01fn \leq f \leq 1.1fn$ step $0.01 fn$	$0.5s \leq t_{13} \leq 3s$, step $0.1s$	$\pm 5\%$	The best of the two data

Model	L2234			Apparatus	Emax	Scale
				Doc.No.	1SDH000460R0002	Page No. 84/155

Protection	Disabling	Disabling of TRIP only	Zone selectivity	Start-up threshold	Thermal memory	Threshold Range	Time Range	Tolerance threshold ⁽²⁾	Time Tolerance ⁽²⁾
LC1/LC2 loads control	<input checked="" type="checkbox"/>	<input type="checkbox"/>	<input type="checkbox"/>	<input type="checkbox"/>	<input type="checkbox"/>	50%÷100% step 0.05x _l			
Warning Iw	<input checked="" type="checkbox"/>	<input type="checkbox"/>	<input type="checkbox"/>	<input type="checkbox"/>	<input type="checkbox"/>	0.30÷3.00% step 0.05x _l			± 10% or 40 ms

⁽¹⁾ The minimum value of this trip is 1s regardless of the type of curve set (self-protection).

⁽²⁾ These tolerances are based on the following assumptions:
- self-supplied relay at full power (without start-up)
- presence of auxiliary power supply
- two-phase or three-phase power supply
- preset trip time ≥ 100ms

⁽³⁾ no-trip time

⁽⁴⁾ the protection G is disabled for current values greater than 4I_n, where I₄ < 0.5 I_n, greater than 6 I_n, where 0.5 I_n ≤ I₄ < 0.8 I_n and greater than 8 I_n where I₄ ≥ 0.8 I_n.

For all cases not covered by the above hypotheses, the following tolerance values apply:

Protections	Trip threshold	Trip time
L	Release between 1.05 and 1.25 x I _l	± 20%
S	± 10%	± 20%
I	± 15%	≤ 60ms
G	± 10%	± 20%
Others		± 20%

14.2.9.15 Table of measurements

Type of measurement	Range	Tolerance	%
Phase and neutral currents	0.3 ... 6 I _n		1.5
Internal ground fault current (internal source ground return)	0.3 ... 4 I _n		1.5
External ground fault current (external source ground return)	0.3 ... 4 I _n		1.5
Phase-to-phase and phase voltages (measured at the module's input and thus independent of the precision relating to the use of any VT)	50 V _{phase-to-phase} ... 1.1x690 V _{phase-to-phase}		1
Residual voltage (for systems with neutral only)	50 V _{phase-to-phase} ... 1.1x690 V _{phase-to-phase}		1
Peak factor	0.3 ... 6 I _n		1.5
Total power factor	0.5 ... 1		2.5
Mains frequency	35 ... 80 Hz		± 0.2
Instantaneous active power on the single phase and total system	0.3 ... 6 P _n		2.5
Instantaneous reactive power on the single phase and total system	0.3 ... 6 P _n		2.5
Instantaneous apparent power on the single phase and total system	0.3 ... 6 P _n		2.5
Active energy	0.3 ... 6 P _n		2.5
Reactive energy	0.3 ... 6 P _n		2.5
Apparent energy	0.3 ... 6 P _n		2.5

Model	L2234		Apparatus	Emax	Scale
			Doc.No.	1SDH000460R0002	Page No. 85/155

14.2.10 Trip curves

The trip curves given are for guidance and only show a sub-group of the possible selections (see par. 14.5.2).

14.2.10.1 Trip curves for functions L-S($t=k/I^2$)-I

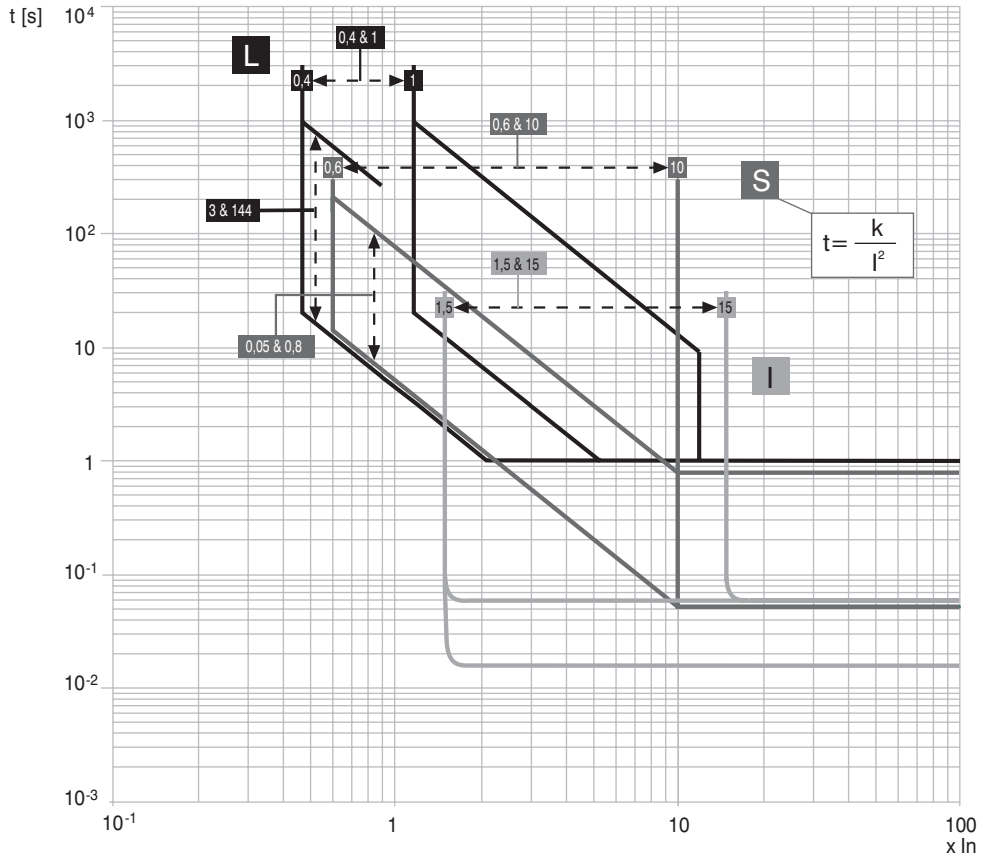

14.2.10.2 Trip curves for functions L-S($t=k$)-I

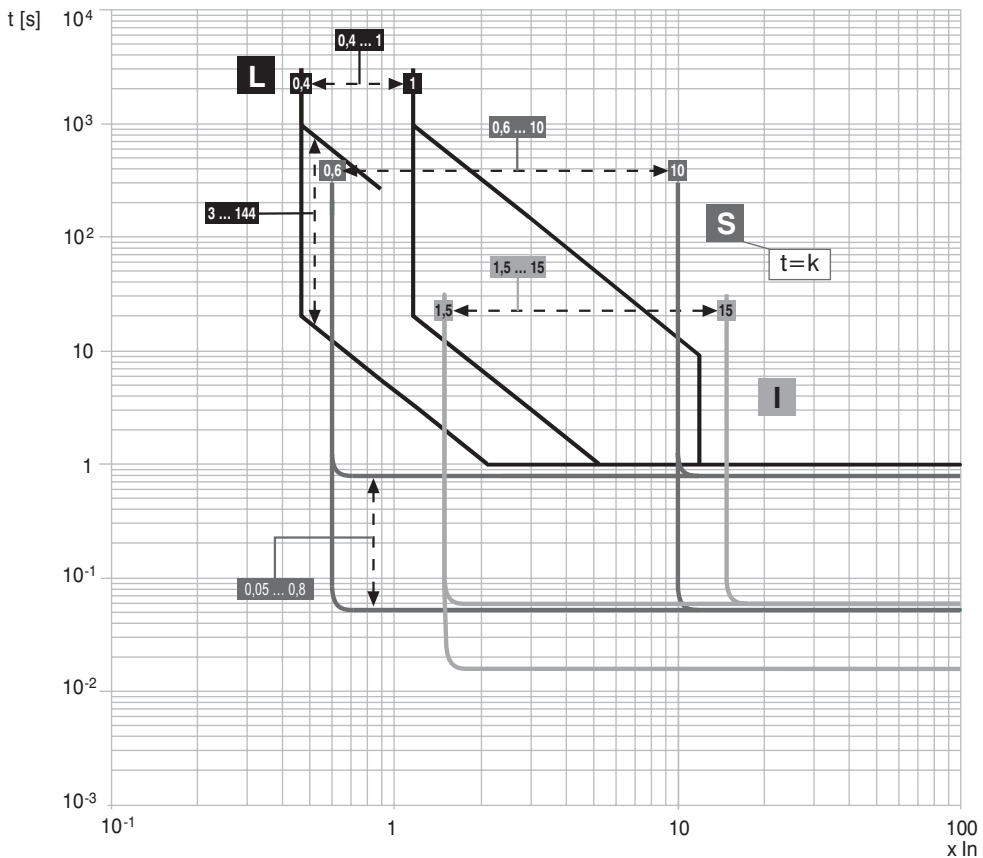

Model	L2234		Apparatus	Emax	Scale
			Doc.No.	1SDH000460R0002	Page No. 86/155

14.2.10.3 Trip curves for function G

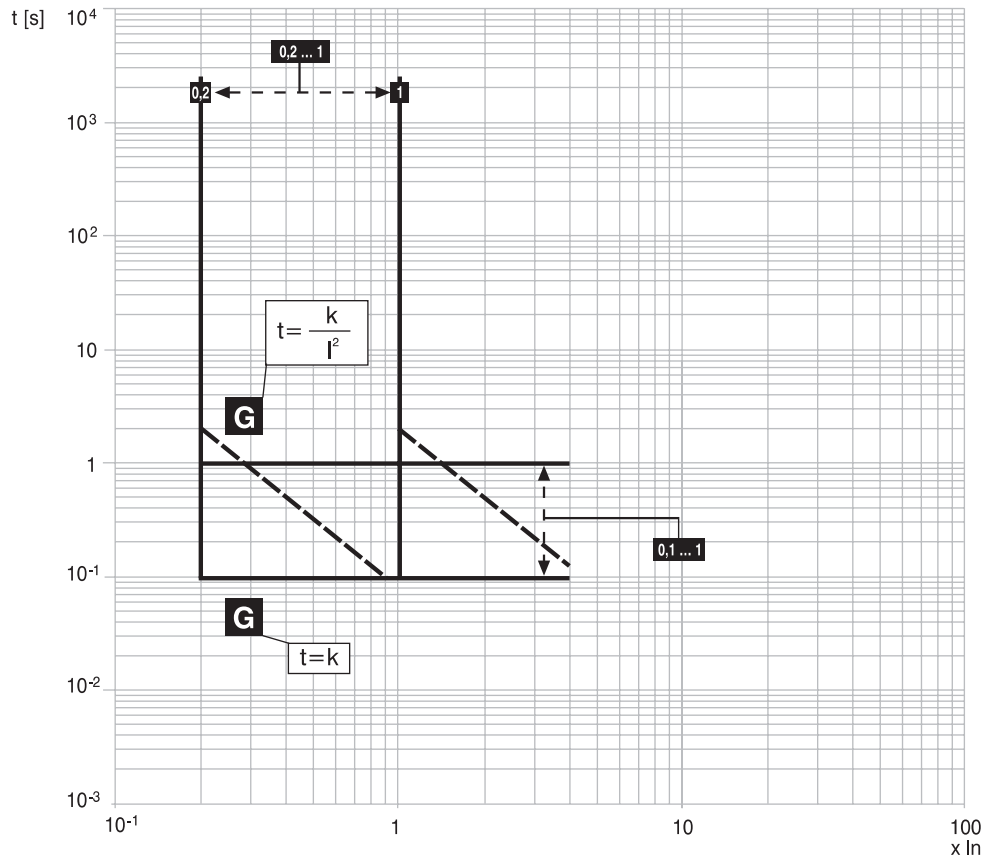

14.2.10.4 Trip curves for function L in accordance with IEC 60255-3 (type A)

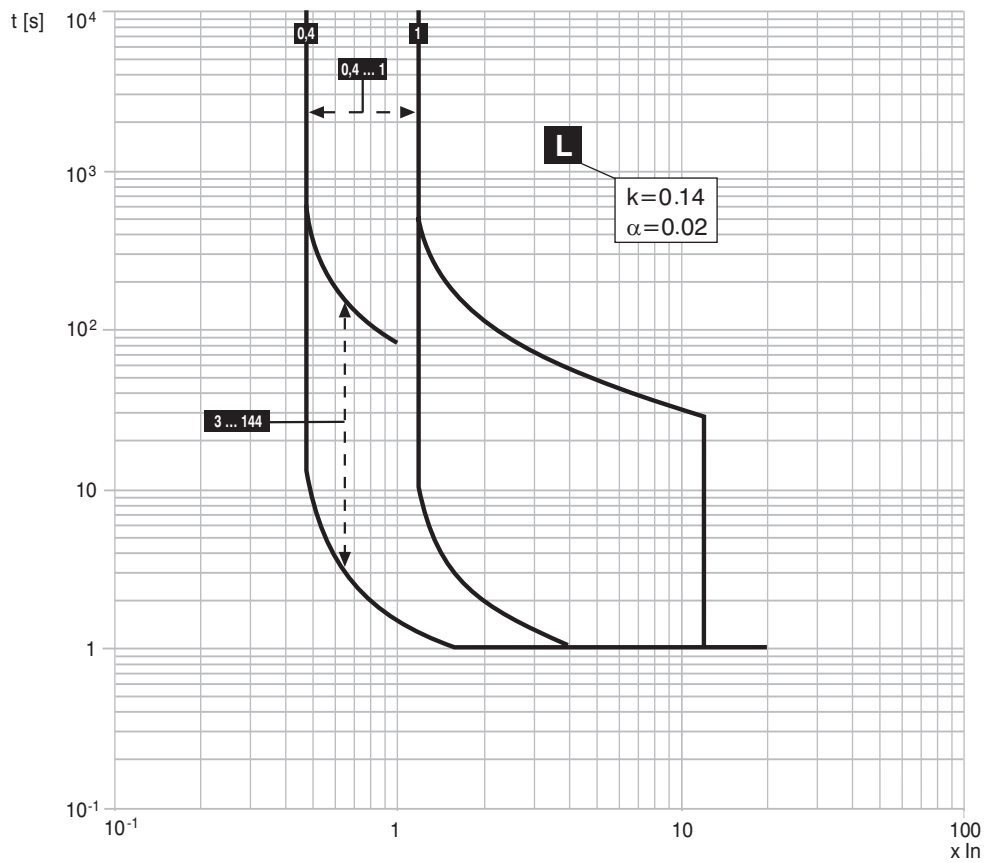

Model	L2234		Apparatus	Emax	Scale
			Doc.No.	1SDH000460R002	Page No. 87/155

14.2.10.5 Trip curves for function L in accordance with IEC 60255-3 (type B)

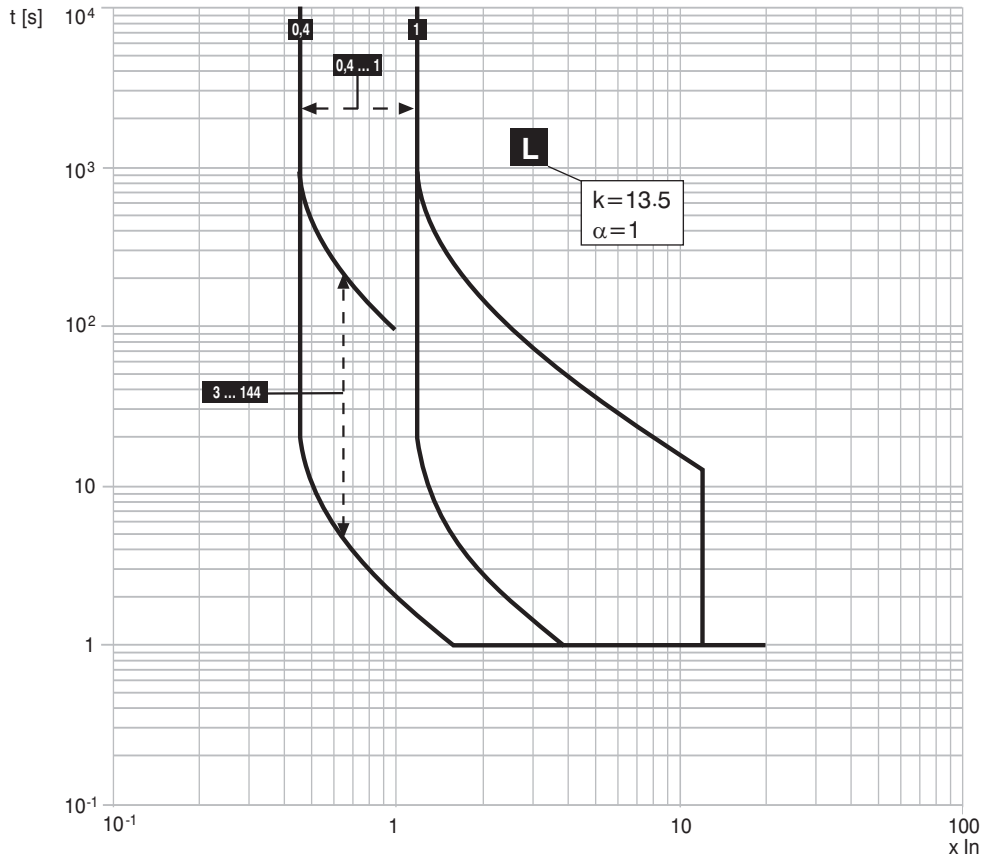

14.2.10.6 Trip curves for function L in accordance with IEC 60255-3 (type C)

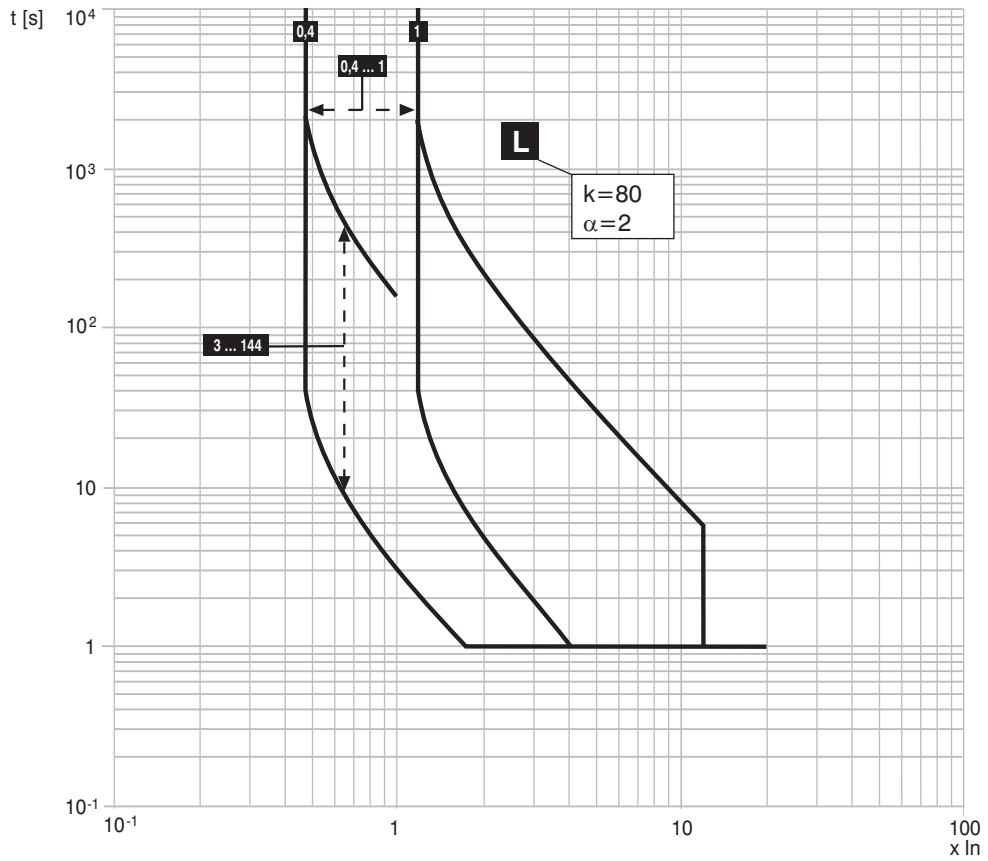

Model	L2234			Apparatus	Emax	Scale
				Doc.No.	1SDH000460R0002	Page No. 88/155

14.2.10.7 Trip curves for function D

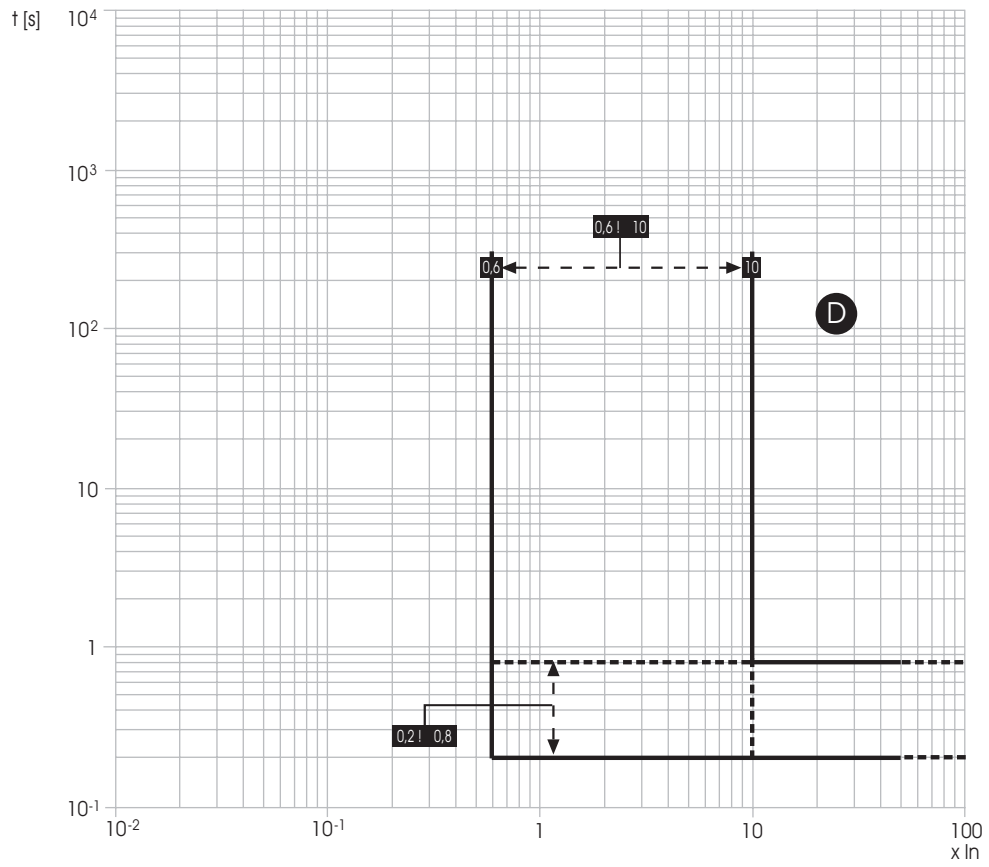

14.2.10.8 Trip curves for function U

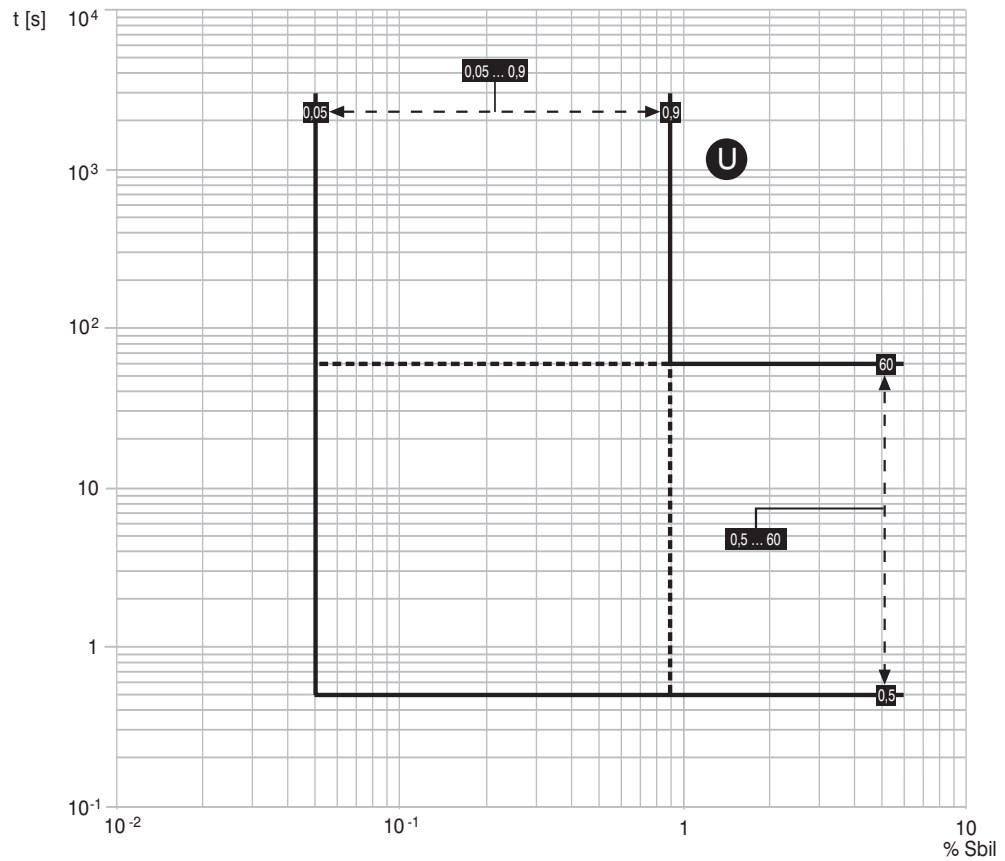

Model	L2234		Apparatus	Emax	Scale
			Doc.No.	1SDH000460R0002	Page No. 89/155

14.2.10.11 Trip curves for function RV

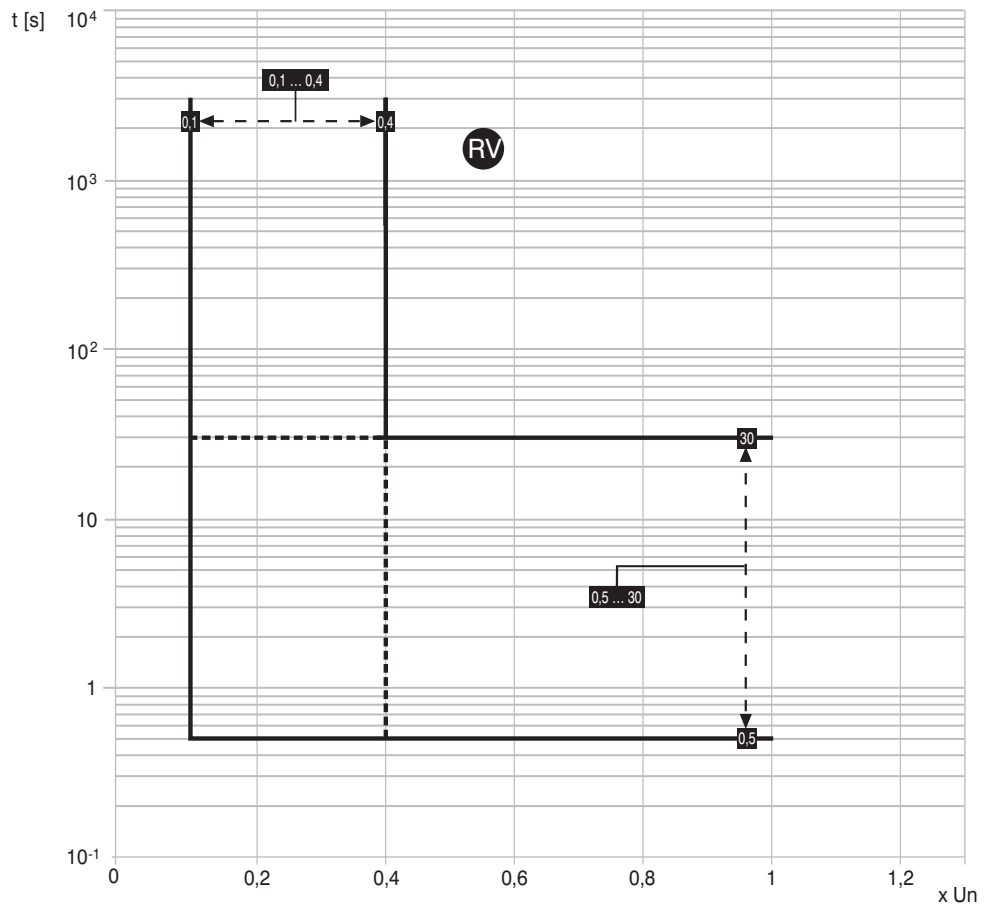

14.2.10.12 Trip curves for function RP

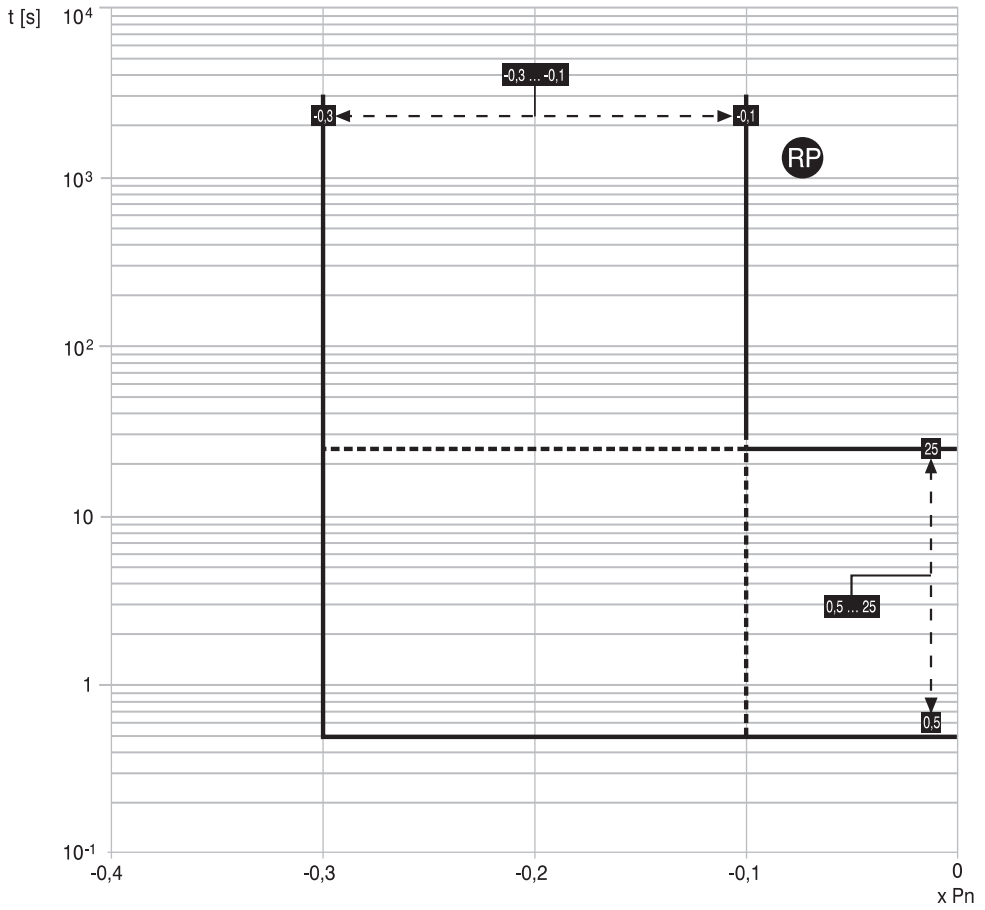

Model	L2234		Apparatus	Emax	Scale
			Doc.No.	1SDH000460R002	Page No. 91/155

14.3 Putting into service

14.3.1 Connections



For the connections provided by the user, it is recommended that you comply strictly with the recommendations contained in this document. This will enable us to satisfy all the international reference standards and guarantee perfect operation of the relay even under severe environmental and electromagnetic conditions.

Pay particular attention to the types of cable, the connections to earth and the recommended maximum distances.



The maximum length of the VT - PR120/V wiring must not exceed 15 meters.

Use corded shielded two-wire cable (see note A to par. 11.2.2).

The shield must be connected to earth on both sides.



Use VTs with a shield, connected to earth (see standard VT par. 14.3.2).

The VTs should only be used for voltages > 690V; for lower voltages the presence of the PR120/V module connected to the lower or higher busbars will be sufficient.

13.3.1.1 Current sensor connection for external neutral



If you want to connect the current sensor for the external neutral conductor to a three-pole circuit breaker, remember to set InN accordingly. During this procedure, the circuit breaker must be open and preferably isolated.

14.3.2 VT connections



Dielectric strength tests are not allowed on the inputs and outputs of the releases or on the secondary lines of any connected VTs

The following is a summary table of standard VT connections according to the type of plant.

VT Standard:

Single standard transformers, see par. 15.1.7.

The VTs must have a performance coming between the values of 10 and 20 VA inclusive, 4 kV insulation between the primary and secondary.

Installation system	"VT Standard" type transformer (Star/Star)	"VT Standard" type transformer (Delta/Delta)
	Application diagram	Application diagram
TN-C	B	A
TN-S	B	A
IT with neutral	B	A
IT	n.c	A
TT with neutral	B	A
TT without neutral	n.c	A

- Note:**
- for TN-C systems the connection must be made to PEN
 - for TN-S systems the connection must be made to N for configurations with neutral or PE for configurations without neutral; if the PE is used, the current thereon could be around a dozen mA. If a customer considers this value too high or has a residual current protection which risks being tripped, then application diagram A must be used.
 - for IT and TT systems with neutral, the connection must be made to N

Application diagram A

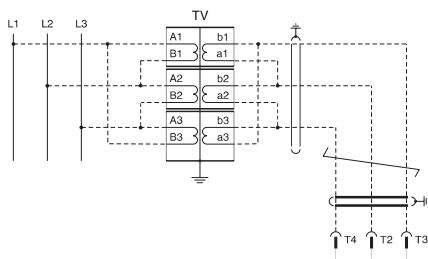

Application diagram B

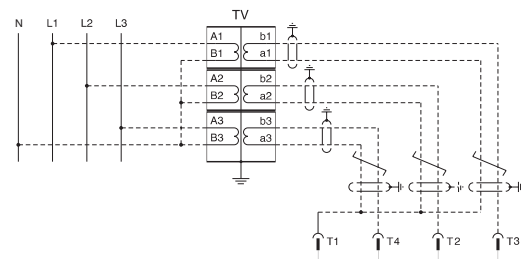

14.3.3 CS and TC connection test



If the PR123/P was installed by the user, it is important, before closing the CB, to check the last line on the display when the relay is turned on for the first time via a PR030/B battery unit. No CS and/or TC disconnected messages must appear; if they do, do not close the circuit-breaker immediately and make the correct connections.

14.3.4 Test

Before putting into service, a test can be conducted by means of the specific "Auto test" function which can be activated on the PR123/P. A positive result is shown on the display.

Then a test can be conducted on the whole TC chain, again using the specific function (Trip test). A positive result is shown by the circuit-breaker opening.

Check the open or closed state of the circuit-breaker on the same "PR123/P Test" screen, by checking "CB Status".

Test	1/6
CB status	
Auto Test	
Trip Test (disabled)	
	CB open

Model	L2234	Apparatus	Emax	Scale
		Doc.No.	1SDH000460R0002	Page No. 92/155

14.3.5 Initial settings

If the PR123/P is supplied ready installed in the circuit-breaker, it is up to ABB SACE to set all the variables referring to the circuit-breaker or the specific application correctly (e.g. type of circuit breaker, Rating Plug size, mains frequency ...).

Vice versa, if the PR123/P is supplied separately, it will be up to the user to set all the necessary parameters correctly.

Note that ABB SACE defines each possible setting according to the content of the paragraph on the default parameters (see par. 14.4.4).



Apart from this, it is absolutely indispensable for the user to modify the password and carefully define each modifiable parameter, before putting the PR123/P into service.

14.3.6 Password management

Specify a password? [0***]

To enter "EDIT" mode it is necessary to enter a four-figure numerical password. The values attributable to the password go from 0000 to 9999. For the default password see par. 14.4.4.

Select the value of the first figure (between '0' and '9') by means of the ↑ and ↓ keys and press ↵ to confirm the figure and then move on to enter the next one.

After entering the fourth figure, check the password you have entered. If the password is correct, you go from the "READ" state to the "EDIT" state.

If the password is wrong, the message

Wrong password

appears and remains until the **ESC** key is pressed (or until an interval of 5 seconds has elapsed).

It is also possible to interrupt the password entry procedure by pressing the **ESC** key.

The password is valid for a maximum of two minutes from the last time a key was pressed. It is immediately reset in the case of a high priority alarm or when the unit is reset.

On entering a page with no modifiable parameters, the state of the protection is put on "READ". If the password is still valid, to enter "EDIT" mode (on a page with modifiable parameters) simply press the ↵ key.

Disabling the Password.

By setting the value of the password to [0000] (on the "Unit configuration" menu) the password prompt is disabled. It is therefore always possible to switch from "READ" to "EDIT".

To enter a new password, select the "New Password" item on the "Settings/System" menu.

14.3.7 Changing the electronic release

14.3.7.1 Installation

To complete the procedure for installing a PR123/P unit, follow the steps below:

1. With the circuit breaker open and preferably isolated, install the protection unit on the circuit breaker
2. Power the unit **ONLY** from the PR030/B
3. If there are no other errors, the display will show the message Configuration (configuration error) accompanied by the yellow LED coming on permanently (warning)
4. Enter the unit's "Settings" menu
5. Select "Circuit breaker"
6. Select "Unit installation"
7. Input the password
8. Select "Install" and press "ENTER"
9. When the red led flashes on and off and the message Installation (installation error) is displayed, remove the PR030/B
10. Power the relay from any other source

Check for the absence of configuration errors.

14.3.7.2 Uninstalling

To complete the procedure for uninstalling a PR123/P unit, follow the steps below:

1. With the circuit breaker open and/or isolated power the unit from the PR030/B
2. Enter the unit's "Settings" menu
3. Select "Circuit breaker"
4. Select "Unit installation"
5. Input the password
6. Select "Uninstall" and press "ENTER"
7. If there are no error messages, remove the PR030/B
8. Remove the PR123/P unit from the circuit breaker
9. The remove the TC connector, proceed as indicated in the figure alongside.

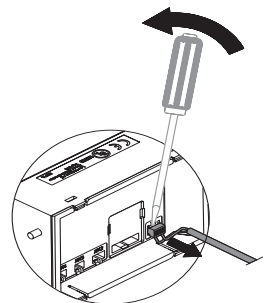

It is not strictly necessary to complete the uninstalling procedure, but this enables the parameters relating to the circuit breaker, such as contact wear and others, to be saved in the "KEY PLUG", otherwise these data would be lost. The data in question are then transmitted to the new PR123/P unit installed on the same circuit breaker.

Model	L2234		Apparatus	Emax	Scale
			Doc.No.	1SDH000460R002	Page No. 93/155

14.4 User interface

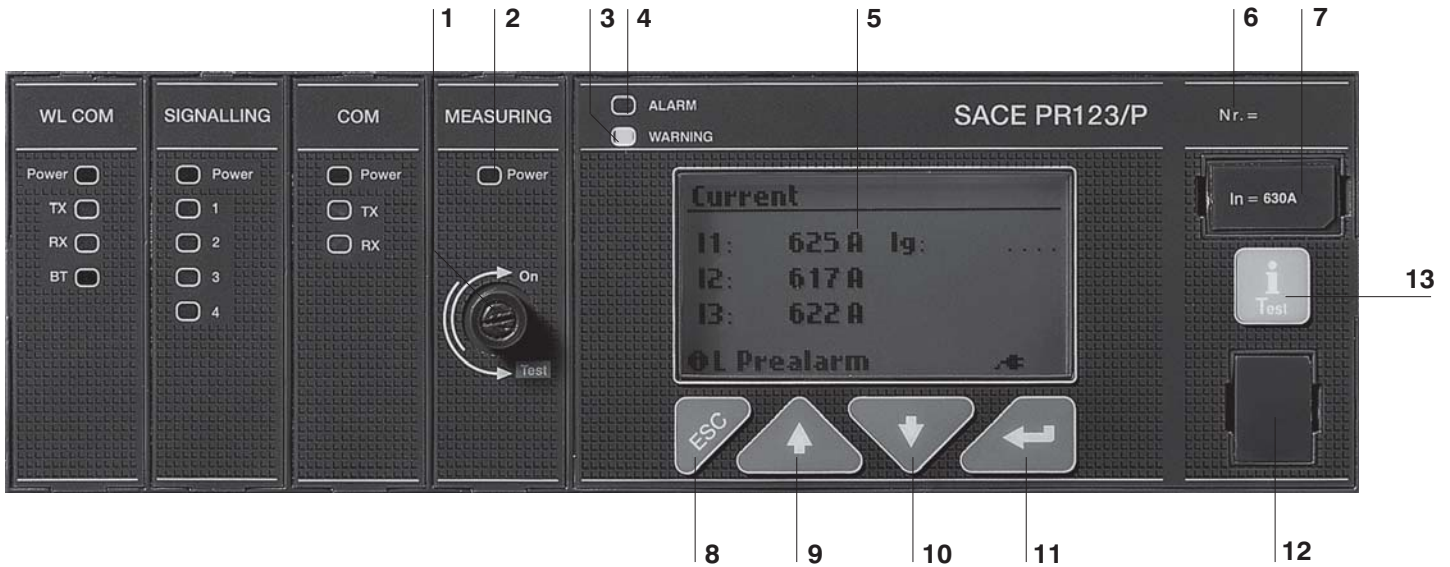

Ref.	Description
1	Voltage takeoff isolator
2	Busbar voltage LED
3	Pre-alarm indicator LED
4	Alarm indicator LED
5	Graphic display (the word ABB in the bottom left-hand corner indicates normal operation)
6	Serial number of the PR123/P
7	Rating plug
8	Pushbutton for exiting the sub-menus or for canceling (ESC)
9	Button for the cursor (UP)
10	Button for the cursor (DOWN)
11	ENTER key for confirming the data or changing the page
12	TEST connector for connecting or testing the release by means of an external device (PR030/B battery unit, BT030 wireless communication unit and PR010/ T test unit)
13	"i Test" test and info button

The Graphic Display is of the LCD type with 128x64 pixels and it is backlit when there is an auxiliary voltage or a self-supply from a PR120/V module. The display is always lit when there is a Vaux or, in self-supply mode with a minimum busbar current or powered from the PR120/V module as defined in par. 14.2.2.1

You can adjust the contrast on the display by means of the specific function available on the user interface settings menu (par. 14.5.4.1).

14.4.1 Use of pushbuttons

The modifiable fields can be filled in using the \uparrow or \downarrow keys and confirming with the \downarrow key. Once you have entered the page you need, you can move from one value to another by using the \uparrow or \downarrow keys. To change a value, position the cursor over the value (the modifiable field will appear in reverse, i.e. white on a black background), and use the \downarrow key.

To confirm the programming of the previously configured parameters, press the **ESC** key once only. A check will be carried out on the parameters entered and then the programming confirmation page will be displayed. To return to the main menu, press the **ESC** key twice.

The **"i Test"** key must be used to perform the Trip test to view the information page and to see the last trip within 48 hours of the CB opening in self-supply mode.

14.4.2 Read and Edit modes

The menu map (see par. 14.5.1) shows all the pages which can be obtained and how to move between them from the keyboard, in the "READ" mode (just to read the data) or in the "EDIT" mode (to set the parameters).

Starting from any page displayed, two different functions can be obtained according to the state of the unit:

1. "READ": the default page will be displayed automatically after about 120 seconds (see par. 14.5.1).
2. "EDIT": the default page will be displayed automatically after about 120 seconds.

The allowable functions depending on the state are:

"READ":

- ✓ Consultation of the measurements and of the historical data
- ✓ Consultation of the unit configuration parameters
- ✓ Consultation of the protection parameters





Model	L2234		Apparatus	Emax	Scale
			Doc.No.	1SDH000460R0002	Page No. 94/155

“EDIT”:

- ✓ Everything allowed in READ mode
- ✓ Configuration of the unit
- ✓ Programming of the parameters relative to the protections
- ✓ TEST Functions of the unit

To access the "EDIT" mode, it is necessary to press the \downarrow key on a page with fields which can be edited. A password will then be required to enable you to switch to the editing mode.

The use of the keys is summarized in the following table:

Key	Function
	Move between pages Move within menu Change parameter values
	End setting phase and confirm result Choose menu item
	Access to surfing menus from the default pages Return to previous level when surfing within the menus, until you return to the default pages Exit the parameter changing phase, aborting the change
	This key is used to re-enable the display after it has gone off within 48 hours of the opening of the circuit breaker in self-supply mode.

14.4.3 Changing parameters

Moving within the Main Menu you can reach all the pages relating to the configurations and parameter settings with the opportunity to change the values specified for the parameters.

After any programming, you need to Confirm/Cancel/Change any changes you have made. This procedure is not applicable to all the programming activities.

Two examples are provided below: one concerns the case in which no confirmation is needed for the changes you have made, while in the other a confirmation window appears.

Procedure not requiring the confirmation of any programming

For instance, to set the System Date, the correct sequence is as follows:

Press ESC to access the Main Menu.



From the Main Menu, select SETTINGS

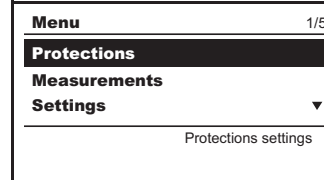

press the \downarrow key (enter)

Select SYSTEM

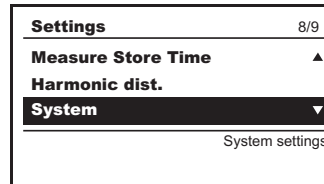

press the \downarrow key (enter)

Select the menu item DATE to change

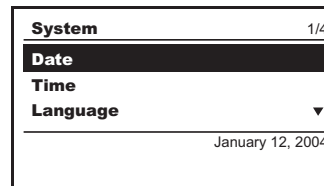

press the \downarrow key (enter)

Model	L2234			Apparatus	Emax	Scale
				Doc.No.	1SDH000460R002	Page No. 95/155

You will be prompted to input a Password
complete the password entry procedure (par. 14.3.6)

press the ↵ key (enter)

A rectangular screen with a title bar 'Password'. The main area shows '0***' in the center and 'Enter password' at the bottom right.

Change the date using the keys ↓ (arrow down)

↑ (arrow up) and confirm by pressing the ↵ key (enter).

Press ESC twice to return to the Main Menu.

A rectangular screen with a title bar 'Date'. The main area shows 'January 12, 2004' in the center.

Procedure requiring the confirmation of any programming

For instance, to change the Curve of the Protection L, the correct sequence is as follows:

Press ESC to access the Main Menu.



From the Main Menu select the item PROTECTIONS

press the ↵ key (enter)

A rectangular screen with a title bar 'Menu' and '1/5' on the right. The main area has a list: 'Protections' (highlighted), 'Measurements', and 'Settings' with a downward arrow. Below the list, it says 'Protections settings'.

From the Protections Menu select the item PROTECTION L

press the ↵ key (enter)

A rectangular screen with a title bar 'Protections' and '1/15' on the right. The main area has a list: 'L Protection' (highlighted), 'S Protection', and 'S2 Protection' with a downward arrow. Below the list, it says 'Overload'.

From the Protection L Menu select the item CURVE

press the ↵ key (enter)

A rectangular screen with a title bar 'L Protection' and '1/4' on the right. The main area has a list: 'Function' (highlighted), 'Threshold I1', and 'Time T1' with a downward arrow. Below the list, it says 't=k/i²'.

You will be prompted to input a Password

complete the password entry procedure (par. 14.3.6)

press the ↵ key (enter)

A rectangular screen with a title bar 'Password'. The main area shows '0***' in the center and 'Enter password' at the bottom right.

Model	L2234			Apparatus	Emax	Scale
				Doc.No.	1SDH000460R0002	Page No. 96/155

Select the value you want from the list and confirm pressing the ↵ key (enter).

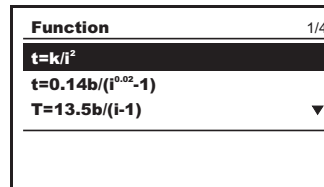

Press ESC twice

Before accessing the Main Menu, the following box will appear:

Accept the new configuration
 Reject the new configuration (the previous configuration is retained)
 Change the previously input values.

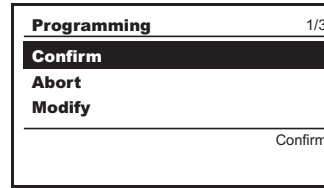

To select the required option use the ↓ (arrow down), ↑ (arrow up) keys, and press ↵ (enter) to confirm.

14.4.3.1 Modification of basic configuration

No parameter settings can be made if the PR123/P unit is in alarm conditions.

The configuration of the unit must be done in EDIT mode.

Following the instructions given in par. 14.4.3, view the following on the display:

Change system date
 Change system time
 Select system language

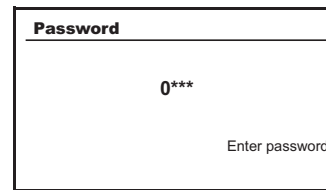
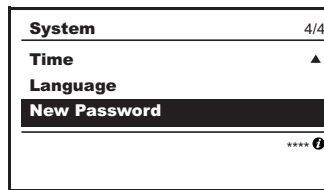
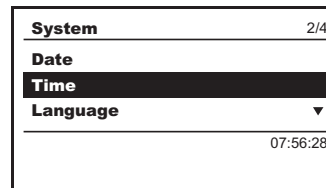

To change the system password, select the relevant menu item and press ↵ (enter); then you will be prompted to enter the OLD password, and afterwards you can input the new one twice.
 Press ESC twice to return to the Main Menu

Before accessing the Main Menu, the following box will appear:

Accept the new configuration
 Reject the new configuration (the previous configuration is retained)
 Change the previously input values.

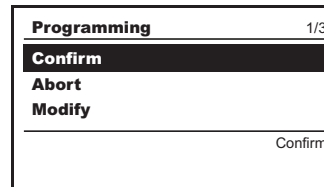

Model	L2234			Apparatus	Emax	Scale
				Doc.No.	1SDH000460R0002	Page No. 97/155

14.4.4 Default settings

The PR123/P is supplied by ABB SACE with the following predefined parameters (Set A and Set B):

#	Protection	On/Off	Thresholds	Time	Curve	T.M.	ZS	Trip
1	L	-	1 In	144 s	I ² t	Off	-	-
2	S	Off	6 In	50 ms	K	-	Off: 0.04s	-
3	D	Off	6 In	0.2s-0.2s			Off: 0.13s	
4	I	On	4 In	-	-	-	-	-
5	G	Off	0.2 In	0.4 s	K	-	Off: 0.04s	On
6	U	Off	50 %	5 s				Off
7	OT	-						Off
8	K LC1	Off	50 % I _n					
9	K LC2	Off	75 % I _n					
10	UV	Off	0.9 Un	5 s				Off
11	OV	Off	1.05 Un	5 s				Off
12	RV	Off	0.15 Un	15 s				Off
13	RP	Off	- 0.1 Pn	10 s				Off
14	UF	Off	0.9 Fn	3 s				Off
15	OF	Off	1.1 Fn	3 s				Off
16	Language	-	Engl					
17	Net Frequency	-	50 Hz					
18	PR021/K	Off						
19	Neutral sel.	-	50 %					
20	Toroid Selec.	-	None					
21	Ext. ground tor.	Off	100 A					
22	Vs Un	-	380V					
23	S startup	Off	6 In	100 ms				
24	I startup	Off	4 In	100 ms				
25	G startup	Off	1 In	100 ms				
26	Password	-	0001					
27	Measuring interval	-	60 min					
28	Iw	Off	3 In					
29	Harmonic dist. warning	Off						
30	Power direction	-	top → bottom					

Model	L2234			Apparatus	Emax	Scale
				Doc.No.	1SDH000460R0002	Page No. 98/155

14.5 Operating instructions / Operation in service

14.5.1 Menu

As seen previously, the PR123/P uses the display to show messages, diagrams and menus. These are organized in a logical and intuitive way. The following is a general layout showing how to access the main menu pages.

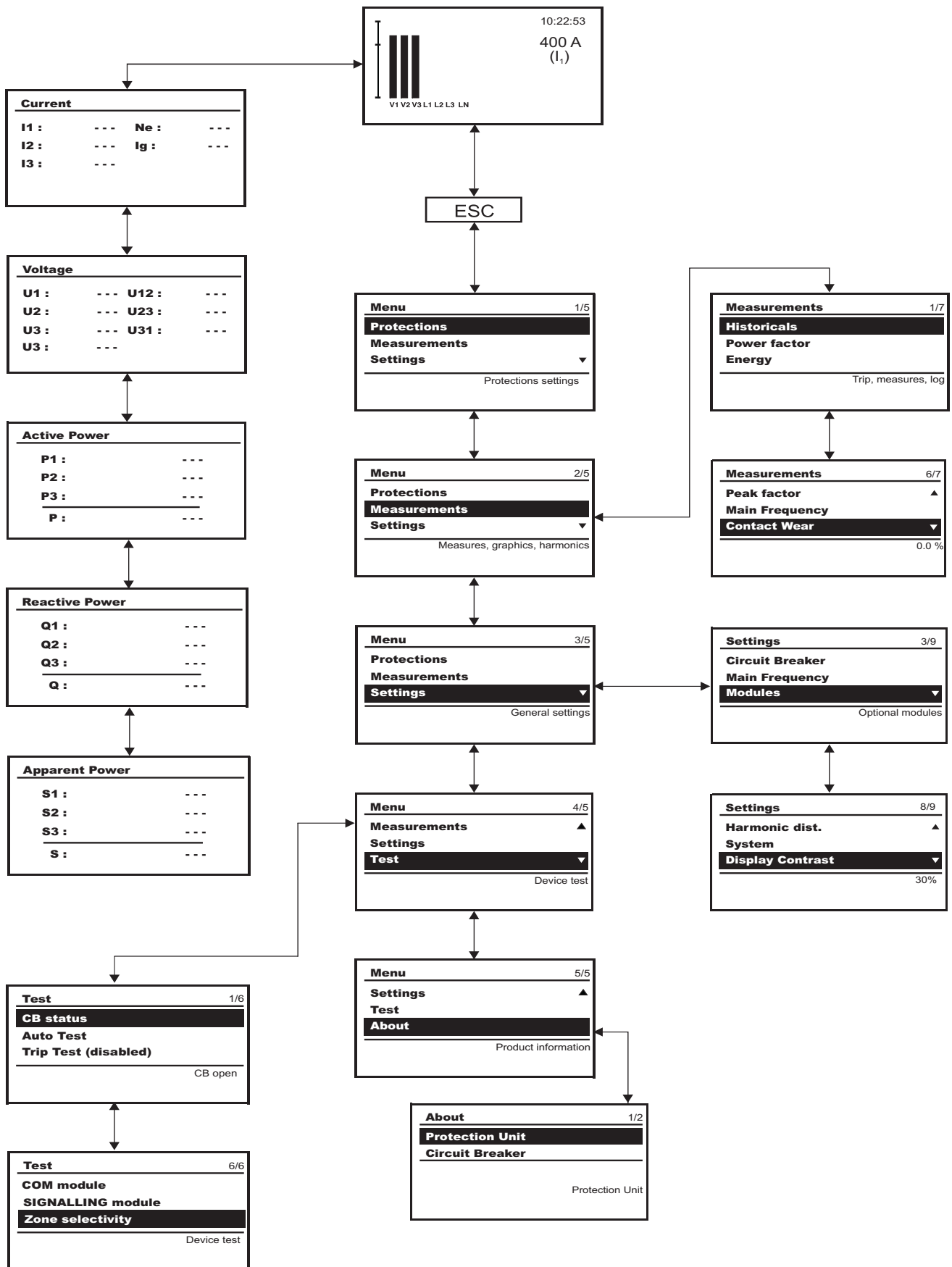

Model	L2234		Apparatus	Emax	Scale
			Doc.No.	1SDH000460R0002	Page No. 99/155

Each time the unit is turned on, or after more than 2 minutes of inactivity on the keyboard, the display indicates the following page (default):

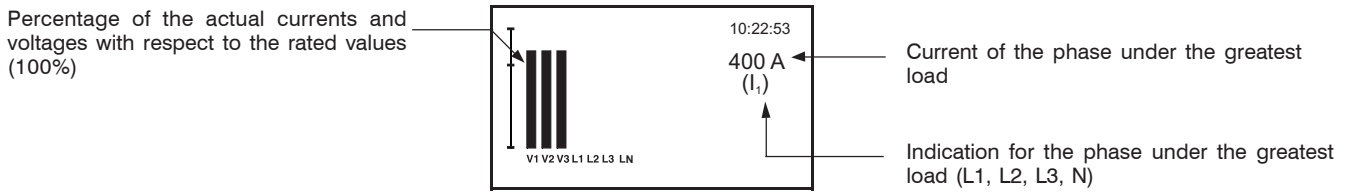

14.5.2 Protections menu

From the interface you can press ENTER to access the menu of the various protections available on the display

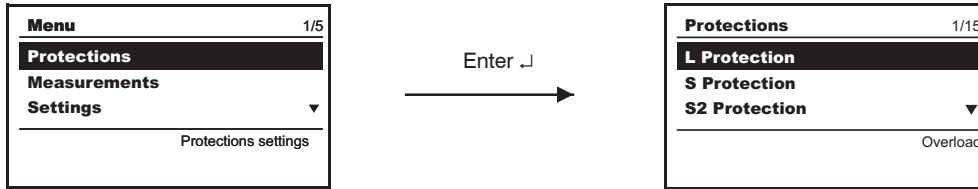

Using the "arrow UP" and "arrow DOWN" you can view the various protections. On the whole, the data that you can display concern the protections: L, S, S2, D, I, G, U, UV, OV, RV, RP, UF, OF, OT, LOAD PROTECTION.

Example of surfing the Protections menu

From the Protection main page you can press ENTER to go to the Protection L Menu. You can use "arrow UP" and "arrow DOWN" to select the items on the menu and confirm by pressing ENTER. Pressing this key triggers a Password prompt, then you can select the functions associated with the protection L (as in the example)

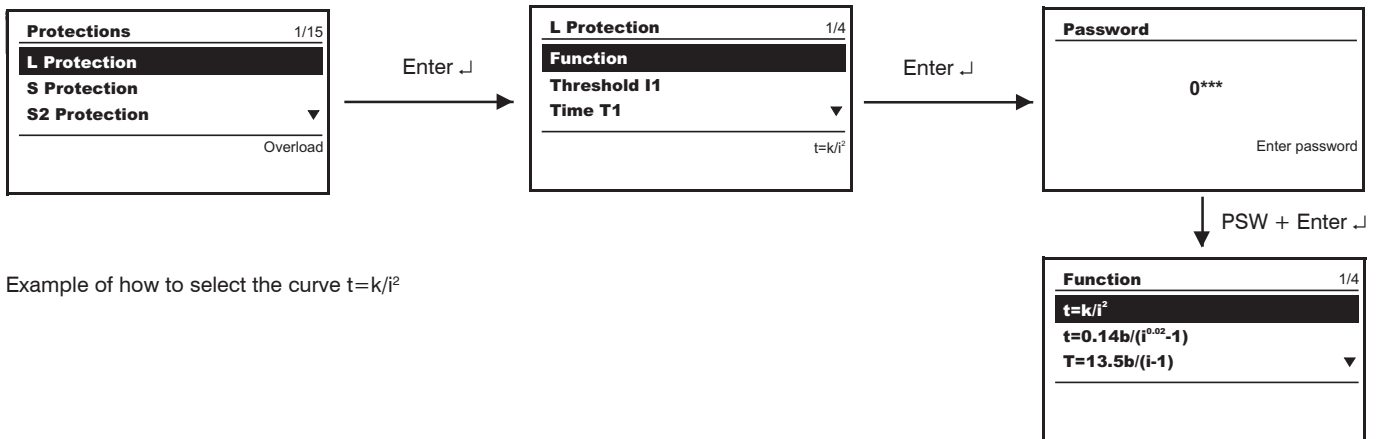

Example of how to select the curve $t=k/i^2$

Similarly, to access the menus for the other protections, see the Protections Menu table below.

14.5.2.1 Protections menu table

Protection	Parameter / Function	
L	Curve	
	Threshold I1	
	Time t1	
	Thermal memory	ON / OFF
S	Enable	ON / OFF
	Curve	
	Threshold I2	
	Time t2	
	Zone selectivity	ON / OFF
	Selectivity time	

Model	L2234		Apparatus	Emax	Scale
			Doc.No.	1SDH000460R0002	Page No. 100/155

Protection	Parameter / Function	
	Enable StartUp	ON / OFF
	StartUp threshold	
	StartUp time	
S2	Enable	ON / OFF
	Threshold I2	
	Time t2	
	Zone selectivity	ON / OFF
	Selectivity time	
	Enable StartUp	ON / OFF
	StartUp threshold	
	StartUp time	
D	Enable	ON / OFF
	Threshold I7	
	Time t7 Fw	
	Time t7 Bw	
	Zone selectivity	ON / OFF
	Selectivity time	
	Enable StartUp	ON / OFF
	StartUp threshold	
	StartUp time	
I	Enable	ON / OFF
	Threshold I3	
	Enable StartUp	ON / OFF
	StartUp threshold	
	StartUp time	
G	Enable	ON / OFF
	Curve	
	Threshold I4	
	Time t4	
	Enable Trip	ON / OFF
	Zone selectivity	ON / OFF
	Selectivity time	
	Enable StartUp	ON / OFF
	StartUp threshold	
	StartUp time	
Gext	Enable	ON / OFF
	Curve	
	Threshold I4	
	Time t4	
	Enable Trip	ON / OFF
	Zone selectivity	ON / OFF
	Selectivity time	

Model	L2234		Apparatus	Emax	Scale
			Doc.No.	1SDH000460R0002	Page No. 101/155

Protection	Parameter / Function	
	Enable StartUp	ON / OFF
	StartUp threshold	
	StartUp time	
U	Enable	ON / OFF
	Threshold I6	
	Time t6	
	Enable Trip	ON / OFF
UV	Enable	ON / OFF
	Threshold U8	
	Time t8	
	Enable Trip	ON / OFF
OV	Enable	ON / OFF
	Threshold U9	
	Time t9	
	Enable Trip	ON / OFF
RV	Enable	ON / OFF
	Threshold U10	
	Time t10	
	Enable Trip	ON / OFF
RP	Enable	ON / OFF
	Threshold P11	
	Time t11	
	Enable Trip	ON / OFF
UF	Enable	ON / OFF
	Threshold f1	
	Time t12	
	Enable Trip	ON / OFF
OF	Enable	ON / OFF
	Threshold f2	
	Time t13	
	Enable Trip	ON / OFF
OT	Enable Trip	ON / OFF
Load Control	Threshold 1 Enable Threshold	ON / OFF
	Threshold 2 Enable Threshold	ON / OFF
	Threshold Iw Enable Threshold	ON / OFF

Note: for an explanation of the characteristics of the single protections and their settings and corresponding curves, see par. 14.2.9.

Model	L2234			Apparatus	Emax	Scale
				Doc.No.	1SDH000460R0002	Page No. 102/155

14.5.3 Measurements Menu

For a complete description of the functions of the PR120/V module, see par. 15.1.
The following is a summary of the parameters accessible from the menu in the PR123/P unit.

14.5.3.1 Measurements Menu table

Setting	Parameter / Function	Values	Notes
Historicals			
	Trips		Last trip
	Events		Events log
	Measurements		
	I Max		Maximum active current
	P Max		Maximum active power
	P Mean		Mean active power
	U Max		Maximum voltage
	U Min		Minimum voltage
	Reset measurements		
Power factor			Cos φ measured
Energy	Energy meters		
	Reset meters		
Peak factor			
Mains frequency		50 Hz 60 Hz	Measured value
Contact wear			Percentage of wear on CB contacts
Waveforms	I1, I2, I3		Graph, harmonics
	N		Graph, harmonics
	Voltage 12, 23, 31		Graph, harmonics

14.5.4 Settings Menu

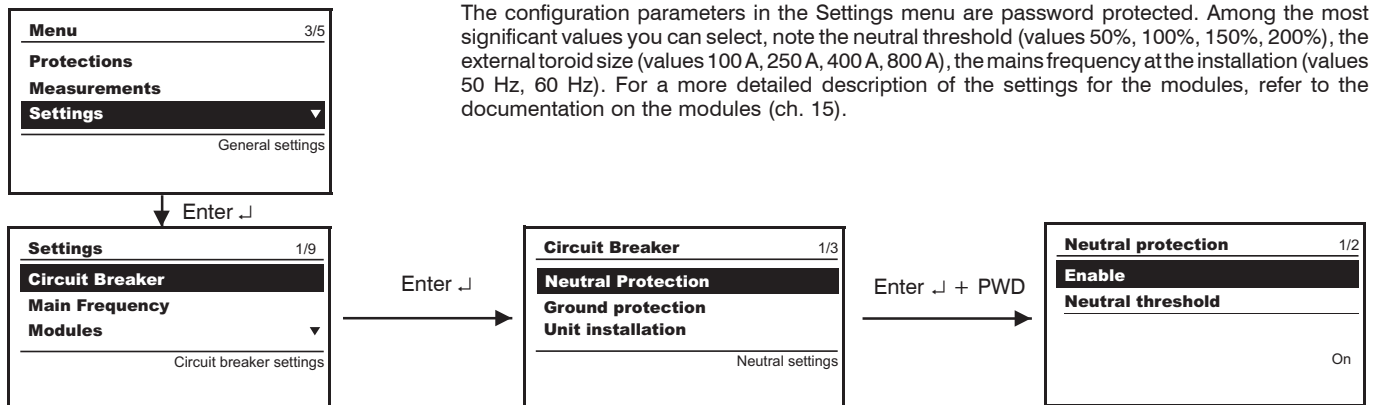

14.5.4.1 Settings Menu table

	Parameter / Function	Values	Notes
Circuit breaker	Neutral protection		
	Enable	ON/OFF	
	Neutral threshold	50%-100%-150%-200%	
	Ground protection		Said protection is provided only in the event of an external toroid being used
	External toroidal transformer	Absent, SGR, Rc	
	Toroid size SGR		
	Toroid size Rc	I _{dn} = 1A, 10A	
Mains frequency		50 Hz - 60Hz	
Modules	Module		
	PR120/V - Measuring	if any	see par. 14.5.4.4.1
	PR120/D-M - COM	if any	see par. 14.5.4.4.2
	PR120/K - Signalling	if any	see par. 14.5.4.4.3
	Local Bus unit	Absent - Present	

Model	L2234		Apparatus	Emax	Scale
			Doc.No.	1SDH000460R002	Page No. 103/155

Parameter / Function	Values	Notes
Data logger Enable	ON/OFF Sampling frequency Stop event Stopping delay Restart Stop	See Annex par. 16.4
Dual setting Enable Default setting Dual Set CB closure Dual Set with Vaux	ON/OFF SET A / SET B	
Measurement interval	from 5 to 120 min, step 5 min	
Harmonic distortion	ON/OFF	The warning indicates that the distortion exceeds factor 2.1
System Date Time Language New password	English/Italiano/Francais/Deutsch/Español	
Display Contrast		

The summary table relates to the surfing of the pages dedicated to the PR120/V module (see par. 15.3) and to the PR021/K unit (see par. 16.1).

14.5.4.2 Neutral adjustment

The neutral protection is normally set to a current value 50% of the adjustment made on the phases.

In some installations, where particularly high harmonics occur, the current circulating on the neutral may be higher than that of the phases.

In the SACE PR123/P release, this protection can be set for the following values: $I_n N = 50\% - 100\% - 150\% - 200\% * I_n$.

The values that can be used to adjust the neutral are given in the table below for the various possible combinations between types of circuit-breaker and adjustment of the threshold I_n .

14.5.4.2.1 Neutral adjustments table

Adjustment for the threshold I_1 (L Protection)			
Circuit breaker size	$I_1 \leq 0.5$	$0.5 < I_1 \leq 0.66^{(1)}$	$I_1 > 0.66$
E1	50-100-150-200%	50-100-150%	50-100%
E2	50-100-150-200%	50-100-150%	50-100%
E3	50-100-150-200%	50-100-150%	50-100%
E4	50-100%	50%	50%
E4/f	50-100-150-200%	50-100-150%	50-100%
E6	50-100%	50%	50%
E6/f	50-100-150-200%	50-100-150%	50-100%

Note 1: The adjustment $I_n = 1 I_n$ is meant as the maximum adjustment of the overload protection. The actual maximum allowable adjustment must take into account any temperature derating, the terminals used and the altitude.



Failure to comply with the setting limits for “ I_n ” and “ $I_n N$ ” can cause circuit breaker damage with consequent risks even for the operator.

In any case, the relay records any setting error between I_1 and the Neutral setting and it signals this by means of the warning (see par. 14.6.3).

14.5.4.3 Mains frequency settings

In the Mains frequency menu, you can choose between the frequency values: 50, 60 Hz.

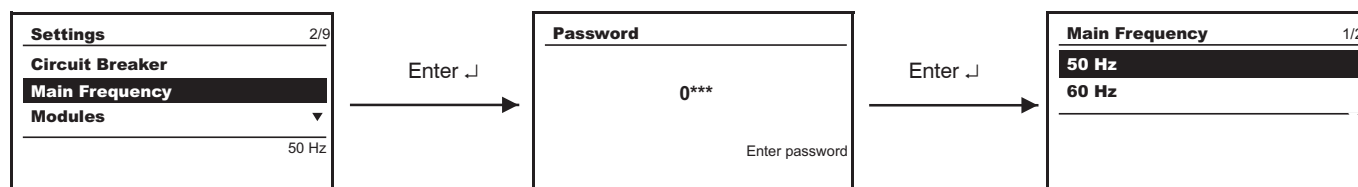

Model	L2234		Apparatus	Emax	Scale
			Doc.No.	1SDH000460R0002	Page No. 104/155

14.5.4.4 Modules

When you access the Settings menu, there is a set of menus available relating to the modules.

14.5.4.4.1 PR120/V - MEASURING module

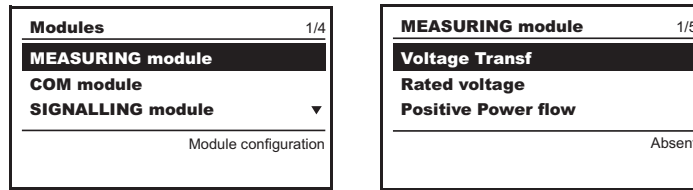

In the measuring module you must enter a password and can then opt for the absence or presence of the voltage transformer. Moreover, you can select the values of the primary voltage (100, 115, 120, ... 1000V) and secondary voltage (100, 110,...,230V). The power flow can be LOW -> HIGH or HIGH-> LOW. After entering a password you can choose whether the neutral connection is to be Absent or Present. The phase sequence and $\cos\phi$ signal can be enabled and disabled (ON /OFF) and the corresponding threshold values can be selected (see par. 15.1).

14.5.4.4.2 PR120/D-M - COM module

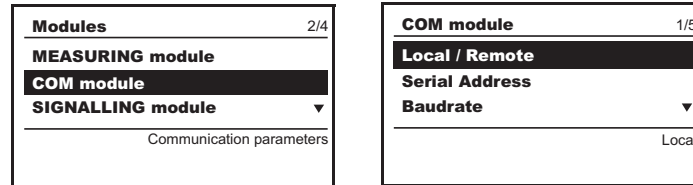

The local or remote modes can be selected after entering a password. The serial address can be displayed after entering a password. The Baud Rate can be set on the values 9600 and 19200 bit/s. The physical protocol provides for the options: (8,E,1), (8,0,1), (8,N,2), (8,N,1). The addressing can be selected as standard Modbus or ABB. For further information on the PR120/D-M communication MODULE, see paragraph 15.2 in this manual .

14.5.4.4.3 PR120/K - SIGNALLING module

For a thorough examination of the signalling module, refer to the corresponding section of the module, paragraph 15.3.

14.5.4.4.4 PR120/D WL-COM module

This module is for wireless communication based on the Bluetooth standard between the PR123/P protection release and a hand-held PC (PDA) or a laptop with a Bluetooth port. For further information, see the description of the module in paragraph 15.4.

14.5.4.4.5 Settings for the Local Bus unit

If the PR021/K unit is connected, you need to enable the local bus by selecting present.

14.5.5 Test Menu

Access to the Test menu is password protected.

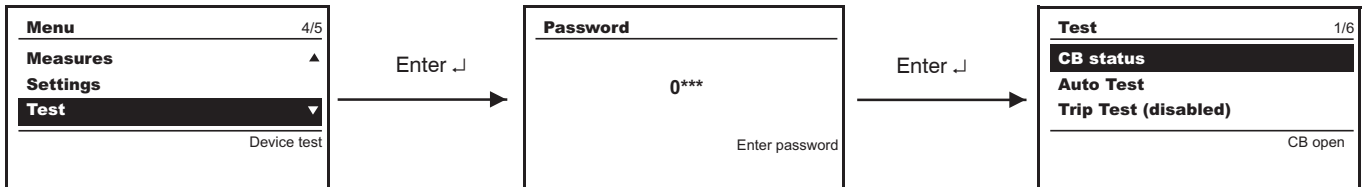

The menu shows the state of the CB, in the dialog module (COM module) the state of the springs and the position of the CB, and in this submenu you can make the CB open or close.

Using the "Trip Test" function lets you view the disabling/enabling of the Trip. If it is enabled, the circuit breaker is opened. The function is only available with a busbar current of nil (use Vaux, PR030/B or PR010/T).

On the page only with Vaux, you can also see the state of the circuit breaker "STATUS", and thus make sure that the input is correctly wired.

Model	L2234		Apparatus	Emax	Scale
			Doc.No.	1SDH000460R002	Page No. 105/155

The surfing path is summarized in the following table:

14.5.5.1 Test Menu table

Parameter / Function		Values	Notes
CB status		Open/Closed Indefinite	INPUT PWD
Auto Test		Display test	
Trip Test		Enabled / Disabled	
PR120/D-M Module	State of springs Position of CB Open CB Close CB	Loaded / Unloaded Isolated / Withdrawn	
PR120/K Module	Input Auto Test	ON ---	
Zone selectivity	Protection S (status) Input Force Output Release Output	ON/OFF	
	Protection G (status) Input Force Output Release Output	ON/OFF	

14.5.6 Information Menu

The Information Menu enables you to view the data relating to the protection unit and the type of circuit breaker.

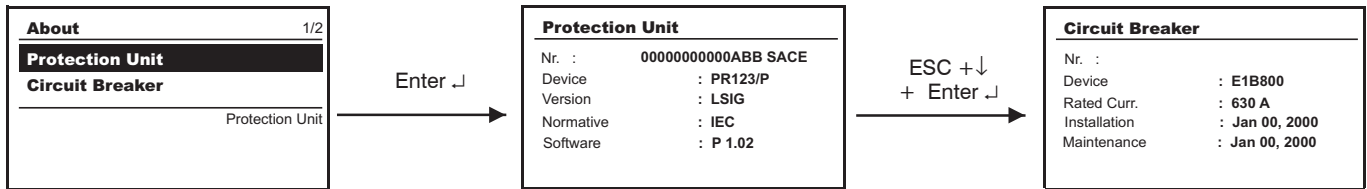

14.5.6.1 Information on the trip and opening data

The PR123/P unit saves all the information relating to the type of protection tripped, the opening data, the date and time. Using the "i Test" key makes the release show all these data directly on the display. There is no need for an auxiliary power supply for this function. With an auxiliary power supply, the information is shown immediately on the display without the need to press the "i Test" key and remains displayed indefinitely until you press the key.

The information remains available for 48 hours with the circuit breaker open or without any current flowing in the busbars. The data relating to the last 20 trips are stored in the unit's memory. By connecting a PR030/B battery unit or a BT030 wireless communication unit, you can retrieve the information relating to the last 20 trips recorded.

Access to view the opening data is via the Historicals submenu in the Measurements menu. The following is an example of the information provided:

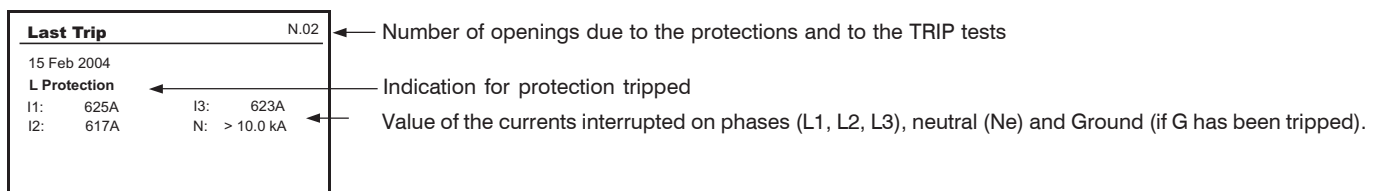

Again in the Measurements menu, you can view the percentage of contact wear, which is an indication of the electrical life of the electrical contacts in the circuit breaker.

In any case, functionality of the relay is in no way modified by the presence of the wear messages.

The prealarm message (wear > 80%, "warning" LED lighting up) indicates that the wear has reached a high value. The alarm message (100% wear, "alarm" LED lighting up) indicates that it is necessary to check the state of contact wear.

The percentage of wear depends on the number of openings carried out by the circuit-breaker and by the absolute current interrupted during each of them.

Model	L2234		Apparatus	Emax	Scale
			Doc.No.	1SDH000460R0002	Page No. 106/155

14.6 Definition of alarms and signals in the PR123/P unit

14.6.1 Optical signals

Signalling	Description
Warning (yellow) led	<ul style="list-style-type: none"> The prealarm threshold has been exceeded; one or more phases with current values in the range $0.9xI_1 < I < 1.05xI_1$. (on the Ne it depends on the selection made; for instance, at 50% the values are halved); Presence, between two or three phases, of unbalance above the value programmed for the "U" protection, with protection trip disabled; Presence of distorted wave form with factor > 2.1; Contact wear greater than 80% (and less than 100% with Vaux only); WARNING Threshold I_w exceeded; Circuit-breaker state error; Frequency out of range.
Alarm (red) led	<ul style="list-style-type: none"> Presence of overload on one or more phases with current values $I > 1.3 I_1$ (timing protection "L") (on the Ne it depends on the selection made; for instance, at 200% the values are doubled)*; Timing in progress for protection function S; Timing in progress for protection function I; Timing in progress for protection function G; Timing in progress for protection function D; Timing in progress for the voltage (UV, OV, RV), frequency (OF, UF) protection functions; Timing in progress for the reverse active power protection function (RP); Timing in the case of unbalance between the phases (protection U) above the value set in the configuration with protection trip set to on; Contact wear = 100%; Rating Plug disconnected; Trip Coil (TC) disconnected; Key plug error; Current sensors disconnected.

* The IEC 60947-2 Standard defines the timing threshold L for current: $1.05 < I < 1.3 I_1$

14.6.2 Electrical signals

K51/p1..p4 Programmable electrical signals, if the PR120/K module or the PR021/K unit are installed and there is an auxiliary power supply. Pressing the "i Test" key enables you to reset the activated contacts.

















14.6.3 Table of error and warning messages

All the messages which can be shown on the display relating to incorrect configurations, generic alarms or deriving from the protection functions and linked to useful information are described below.































The following symbols in the warning signals have the following meanings:

 = warning signal / Protection in alarm mode, with no trip (trip=off)

 = Protection in alarm mode, with trip at end of delay (trip=on)















Error message	Description	Notes
 Harmonic dist.	Harmonic distortion alarm	Busbar currents with form factor > 2.1
 Contact wear	Alarm for contact wear	Contact wear = 100%
 G	Alarm for protection G	
 Gext	Alarm for protection Gext	
 T Alarm	Alarm for protection T	Temperature outside range
 T	Alarm for protection T	
 U Alarm	Alarm for protection U	Protection U delay counting down
 UV Alarm	Alarm for protection UV	
 OV Alarm	Alarm for protection OV	
 RV Alarm	Alarm for protection RV	
 RP Alarm	Alarm for protection RP	
 UF Alarm	Alarm for protection UF	
 OF Alarm	Alarm for protection OF	
 LC1 Load	Alarm for load control LC1	
 LC1 Load	Alarm for load control LC2	
 L1 Sensor	Alarm for L1 phase current sensor	Phase L1 sensor disconnected or faulty

Model	L2234		Apparatus	Emax	Scale
			Doc.No.	1SDH000460R002	Page No. 107/155

Error message	Description	Notes
 L2 Sensor	Alarm for L2 phase current sensor	Phase L2 sensor disconnected or faulty
 L3 Sensor	Alarm for L3 phase current sensor	Phase L3 sensor disconnected or faulty
 Ne Sensor	Alarm for Ne phase current sensor	Phase Ne sensor disconnected or faulty
 Gext Sensor	Alarm for Gext current sensor	Gext sensor disconnected or faulty
 TC disconnected	Trip Coil disconnected or faulty	
 Rating Plug	Rating Plug Error absent or faulty	
 Power factor	Power factor error	The power factor module is lower than the specified threshold
 Phase cycle	Phase cycle inverted	
 Invalid date	Clock information lost	
 CB status	CB status error	Probable error in Q26 and/or Q27
 Startup	Error during relay installation	
 CB not defined	State of circuit breaker inconsistent (Open/Closed)	Probable error in Q26 and/or Q27
 Local Bus	Local Bus error	See par. 14.7
 Contact wear	Contact wear prealarm	Contact wear $\geq 80\%$
 L prealarm	Protection L prealarm	
 T prealarm	Protection T prealarm	
 Frequency range	Error: frequency out of range	
 Warning lw	lw threshold exceeded	
 Timing L	Timing protection L	
 Timing S	Timing protection S	
 Timing S2	Timing protection S2	
 Timing G	Timing protection G	
 Timing Gext	Timing protection Gext	
 Timing D	Timing protection D	
 Timing U	Timing protection U	
 Timing UV	Timing protection UV	
 Timing OV	Timing protection OV	
 Timing RV	Timing protection RV	
 Timing RP	Timing protection RP	
 Timing UF	Timing protection UF	
 Timing OF	Timing protection OF	

14.6.4 Error messages displayed in pop-up windows

All the messages that appear on the display in a pop-up window are described below.

Error message	Description
 Password error	
 Session impossible	A programming session cannot be started due to a contingency (e.g. a timer-controlled delay still elapsing)
 Value outside range	Value beyond the established limits
 $I2(S) \leq I1(L)$	Incongruence between thresholds of protections L and S or S2
 $I3(I) \leq I2(S)$	Incongruence between thresholds of protections I and S or S2
 $I3(I) \leq I7(D)$	Incongruence between thresholds of protections I and D
 $I7(D) \leq I1(L)$	Incongruence between thresholds of protections L and D
 Sel. D/S	Zone selectivity enabled in both protection D and S or S2
 Sel. D/G	Zone selectivity enabled in both protection D and G or Gext
 NEC	NEC requirements not satisfied
 Unavailable	Function is not available
 Invalid date	Date has not been set
 Parameters revised	Programming session concluded correctly
 Cancelled	Programming session cancelled
 Failed	Programming session rejected



Model	L2234			Apparatus	Emax	Scale
				Doc.No.	1SDH000460R0002	Page No. 108/155

14.7 Troubleshooting PR123/P unit

The following table lists a series of typical service conditions, to help you understand and solve hypothetical faults or malfunctions.

Note:

1. Before consulting the following table, check for any error messages appearing for some seconds on the display.
2. FN indicates the normal operation of the PR123/P.
3. In the case where the suggestions proposed do not lead to a solution of the problem, please contact the ABB SACE assistance service.

N°	Situation	Possible causes	Suggestions
1	The trip test cannot be run	1. The busbar current is > 0 2. The TC is not connected	1. FN 2. Check the messages on the display
2	Trip times lower than expected	1. Threshold too low 2. Curve too low 3. Thermal memory enabled 4. Incorrect Neutral Selection 5. The SdZ is inserted	1. Correct threshold 2. Correct curve 3. Exclude if not necessary 4. Correct Neutral Selection 5. Exclude if not necessary
3	Trip times higher than expected	1. Threshold too high 2. Curve too high 3. Curve I ² t inserted 4. Incorrect Neutral Selection	1. Correct threshold 2. Correct curve 3. Exclude if not necessary 4. Correct Neutral Selection
4	Rapid trip, with I3=Off	Inst tripped	FN with short-circuit with high I
5	High earth I, but no trip happens	1. Incorrect selection of the sensor 2. Function G prevented with I>4 In	1. Set int. or ext. sensor 2. FN
6	Display off	1. Vaux missing and the current and/or voltage are below the minimum value 2. Temperature out of range	1. FN, see 14.2.2.1 2. FN, see 14.2.9.8
7	The display is not back-lit	Current and/or voltages below the limit for lighting the display	FN
8	Reading of I incorrect	Current below the minimum threshold that can be displayed	FN
9	Reading of V, W and power factor incorrect	1) Connection error between VT and PR120/V 2) VT parameter settings error	1) Check connections between VT and PR120 2) Set the correct parameters
10	"  Local Bus" message on display	No communication between PR123/P and PR021/K	1. If not present, disable PR021/K, see 14.5.4.4.5 2. Check bus connection 3. Check PR021/K
11	Message "" instead of expected data	Function disabled or data out of range	FN
12	The expected trip does not occur	Trip function disabled	FN enable trip if necessary
13	No activation of the Unbalance U protection	Values of I out of range	FN, see 14.2.9.7
14	No display of the opening data	Vaux missing, the buffer capacitor is discharged	FN, see 14.5.6.1
15	The password is not requested	The password has been disabled	FN, re-enter the password with a value other than 0000
16	Impossible to change any parameter	PR123/P in alarm situation	FN
17	"  Sensor time" or "  Start-up" message	Possible failure inside relay	Contact ABB Sace

14.7.1 In the case of a fault



If you suspect that the PR123/P is faulty, has a malfunction or has generated an unwanted trip, it is advisable to follow the recommendations below very carefully from the Measurements menu, —> Historicals —> Trip:

1. Make a note of the type of protection that has tripped by accessing the LAST TRIP page if there is an external power supply (Vaux or battery) or by pressing "i Test" if in self-supply mode.
2. Note down the type of circuit-breaker, number of poles, any accessories connected, I_n, Serial Number (see par. 14.4) and the SW version.
3. Prepare a brief description of the opening (when did it happen?, how many times?, was it always under the same conditions? what type of load? what voltage? what current? is the event reproducible?)
4. Send/communicate all the information collected, together with the circuit diagram for the circuit-breaker, to your nearest ABB Customer Support service.

The completeness and accuracy of the information given to the ABB Assistance service will facilitate technical analysis of the problem encountered, and will allow us to carry out all actions useful for the user rapidly.

Model	L2234		Apparatus	Emax	Scale
			Doc.No.	1SDH000460R002	Page No. 109/155

14.8 Accessories

14.8.1 ABB SACE PR010/T test and configuration unit

The test with the SACE PR010/T unit enables you to check the proper operation of the inputs, outputs, thresholds and tripping times of the protection functions "L", "S", "I", "G", OV, UV, RV, U. The test unit is connected to the relay by means of the front Test connector (see par. 14.4).

14.8.2 ABB SACE PR030/B power supply unit

The PR030/B is a momentary power supply unit to be inserted in the front test connector of the PR123/P.

Using this standard accessory, you can run an autotest, the trip test, and power the PR123/P unit whatever the state of the circuit breaker (open/closed, in the test position or enabled and without an auxiliary power supply).

The battery inside the PR030/B guarantees a power supply to the unit for about 3h continuously (depending on the operations conducted on the PR123/P and on the PR120/D-BT module).

The life of the battery diminishes if the PR030/B accessory is also used to perform the trip test and the autotest. It is essential to use the PR030/B to read the trip data if the trip has occurred more than 48 hours earlier and the release was no longer powered.

14.8.3 BT030 wireless communication unit

The BT030 is a device for connecting to the Test connection on the PR123/P.

It enables Bluetooth communication between the protection release and a hand-held or laptop PC with a Bluetooth port.

This device is dedicated for use with the SD-Pocket application.

The BT030 has a rechargeable Li-ion battery that can provide the power needed for it to function and for the protection release.

Model	L2234			Apparatus	Emax	Scale
				Doc.No.	1SDH000460R0002	Page No. 110/155

15 Modules

15.1 PR120/V - MEASURING Module

15.1.1 General characteristics

The MEASURING module records and processes the phase voltages. The measurements are sent by the module to the protection release, enabling the implementation of a set of protection and measurement functions. The module comes with a "Power" LED and a sealable isolator for dielectric stiffness tests. The module also enables the relay to be powered.

15.1.2 Front view

- "Power" LED
- Isolator

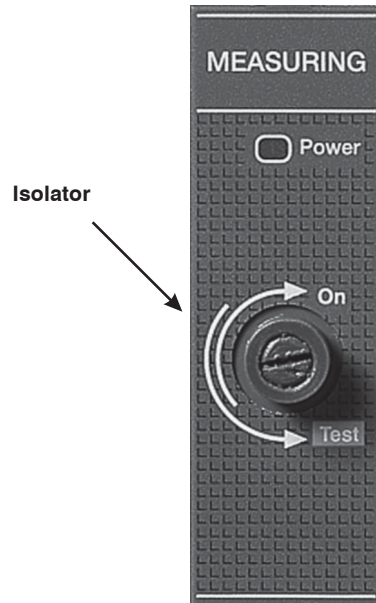

Before performing the dielectric stiffness test it is essential to turn the isolator into the Test position mode by turning the screw anticlockwise until you reach the end of stroke position.



After performing a dielectric stiffness test, restore the isolator to its original position by turning it clockwise until you reach the opposite end of stroke, because all the voltage protections are disabled while the isolator is in the test position.

Dielectric stiffness tests on any voltage transformers connected to the secondary lines alone are prohibited.

At the end of the procedure, make sure that the Power ON LED is on.

15.1.3 Releases with the module

- standard for PR123/P
- optional for PR122/P.

15.1.4 Powering the PR122/P and PR123/P units via the PR120/V module

The PR122/P and PR123/P units are powered by the MEASURING module via the busbar voltage. The powering stage is capable of operating starting from a voltage of 80Vrms two-phase phase to phase up to 897Vrms (1.3 * 690Vrms) three-phase phase to phase at its input (coming directly from the busbars or from a transformer secondary). In the case of three-phase systems with a rated voltage greater than 690Vrms phase to phase, a step-down transformer (with a transformation ratio of less than 1) is used. See par. 15.1.7.

The minimum three-phase busbar voltage needed to power the PR122 or PR123 relay alone (without any additional modules) is 35 Vrms.

The following tables show the phase-to-phase voltage values at the MEASURING module's input for which the relays and modules are enabled:

PR123/P Relay + PR120/K Module

ENABLING THE UNIT AND ITS FUNCTIONS			THREE-PHASE (phase-to-phase voltage)
PR123/P Relay	4 PR120/K active contacts	Relay display backlighting	Enabling threshold
☒			60Vrms
☒	☒		70Vrms
☒	☒	☒	90Vrms

Model	L2234		Apparatus	Emax	Scale
			Doc.No.	1SDH000460R0002	Page No. 111/155

PR123/P Relay + PR120/ D-BT - WL-COM Module

ENABLING THE UNIT AND ITS FUNCTIONS			THREE-PHASE(phase-to-phase voltage)
PR123/P Relay	PR120/D-BT WL module	Relay display backlighting	Enabling threshold
☒			60Vrms
☒	☒	☒	70Vrms

PR123/P Relay + PR120/K Module + PR120/D-BT - WL-COM Module

ENABLING THE UNIT AND ITS FUNCTIONS				THREE-PHASE(phase-to-phase voltage)
PR123/P Relay	4PR120/Kactive contacts	PR120/D-BT WL module	Relay display backlighting	Enabling threshold
☒				
☒	☒			70Vrms
☒	☒	☒		90Vrms
☒	☒	☒	☒	110Vrms

N.B.: for proper connection of PR120/V module, see figs. 43, 44 and 48 of Electric diagram.

15.1.5 Operating instructions / Operation in service

15.1.5.1 Using the Measurement submenus with the PR120/V

The menu for accessing the functions of the module, which is always provided on the PR123/P, but optional for the PR122/P, is illustrated below.

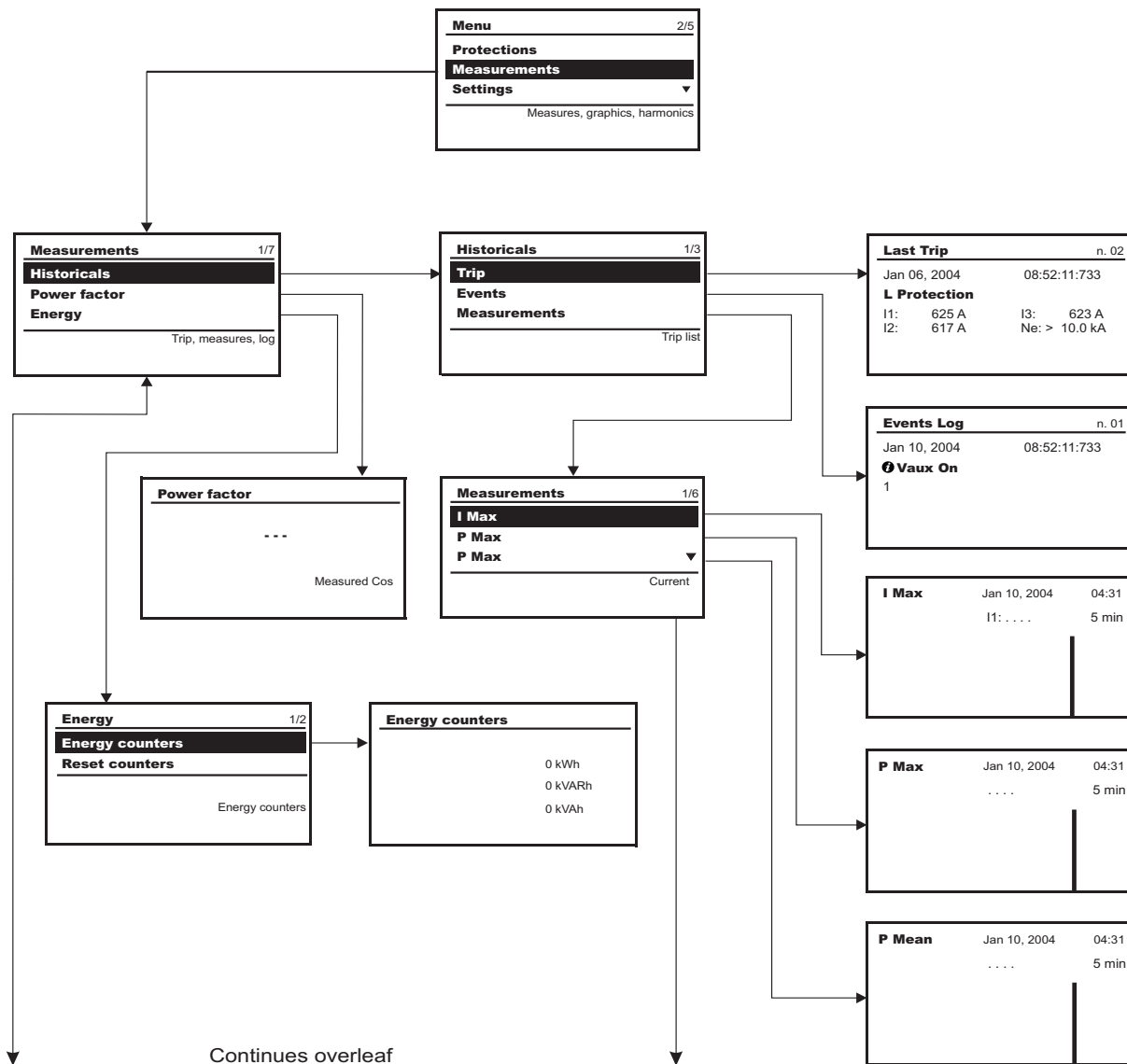

Continues overleaf

Model	L2234		Apparatus	Emax	Scale
			Doc.No.	1SDH000460R0002	Page No. 112/155

Continues from previous page

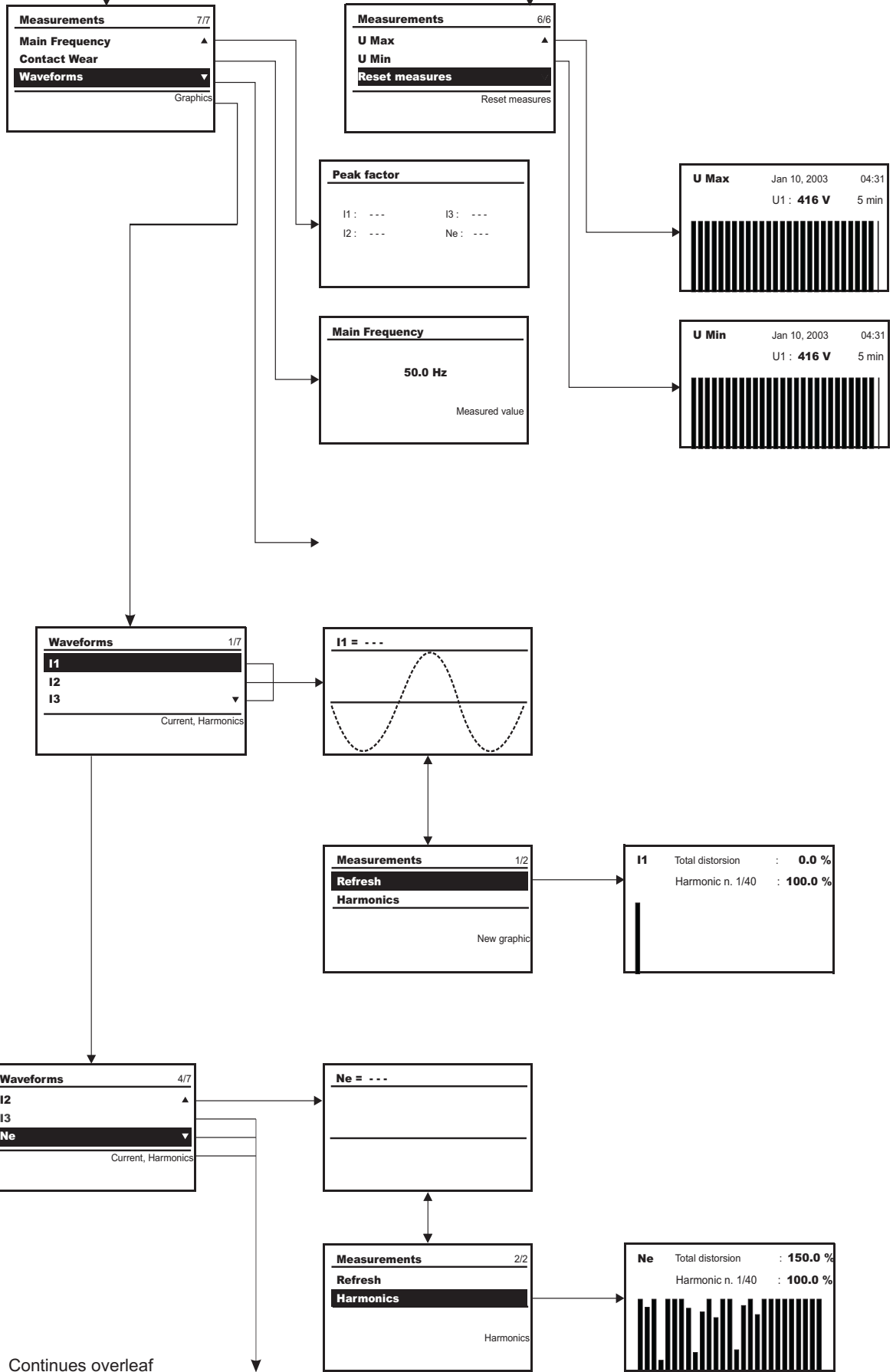

Continues overleaf

Model	L2234		Apparatus	Emax	Scale
			Doc.No.	1SDH000460R002	Page No. 113/155

Continues from previous page

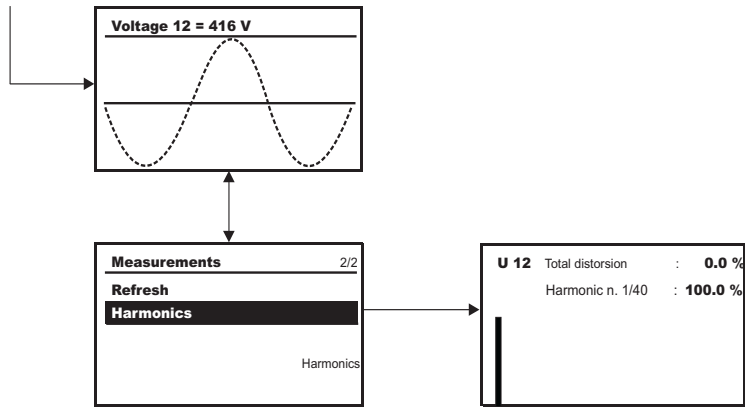

15.1.5.2 Table of submenus for the PR120/V module

This menu is accessible using the path "Settings/Modules/ PR120/V module"

Parameter / Function		Values	Notes
Voltage transformer		Absent	for voltages below 690V
	Rated voltage	100V-115V-120V-190V 208V-220V-230V-240V 277V-347V-380V-400V 415V-440V-480V-500V 550V-600V-660V-690V	
Voltage transformer		Present	for voltages above 690V, see par. 15.1.7
	Primary voltage	100V-115V-120V-190V 208V-220V-230V-240V 277V-347V-380V-400V 415V-440V-480V-500V 550V-600V-660V-690V 910V-950V-1000V-1150V	
	Secondary voltage	100V-110V-115V-120V 200V-230V	
Power flow		Low → High High → Low	PR120/V connected to the bottom CB terminals PR120/V connected to the top CB terminals
Signals	Phase sequence		
	Enabling status	ON/OFF	
	Threshold	123/321	can be selected if enabling status is ON
	Cos φ		
	Enabling status	ON/OFF	
	Threshold	from 0.5 to 0.95 step 0.01	

15.1.5.3 Measurements menu table

For the sake of simplicity, the table refers to the Measurements menu already provided in the PR123/P, which is also applicable for the PR122/P fitted with a PR120/V module.

Parameter / Function		Values	Notes
Historicals	Trips		List of trips
	Events		Events log
	Measurements		
	Maximum current		
	Maximum active power		
	Mean active power		
	Reset measurements		
Power factor			measured Cos φ available in self-supply mode
Energy	Energy meters		
	Reset meters		

Model	L2234		Apparatus	Emax	Scale
			Doc.No.	1SDH000460R0002	Page No. 114/155

Peak factor		Peak value/rms value available in self-supply mode
Mains frequency	50-60Hz	Measured value available in self-supply mode
Contact wear		Percentage of contact wear
Waveforms	Current I1/I2/I3/Ne Refresh Harmonics Voltage 12/23/31 Refresh Harmonics	

15.1.5.4 Measurements menu

15.1.5.4.1 Historicals

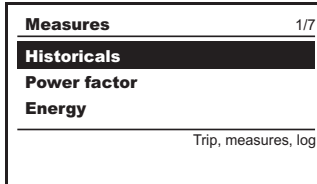

A whole range of measurements is accessible from the "Measurements/Historicals" menu.

15.1.5.4.2 Trips

The following is an example of a page showing the latest trip. You can access said page by selecting Trips via the path Measurements / Historicals / Trips. The page shows the values for the type of protection that has been tripped (L in the example).

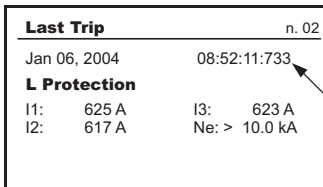

Meter: counts progressively (0 ... 65,535) as of the date of the latest trips reset. It shows the latest 20 trips which can still be selected.

Time (in hours and minutes) when CB opened

15.1.5.4.3 Events

The following table shows a typical page concerning the latest events Log. You can access said page by selecting Events via the path Measurements / Historicals / Events.

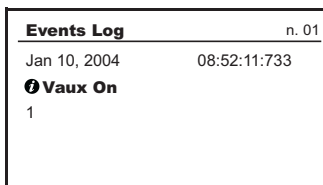

Meter: indicates "Latest" and measures the previous events in the sequence -1, -2 up to -80 (e.g., the last but one is shown as -1)

15.1.5.4.4 Measurements

This menu is for showing the following measurements:

- I Max** - Maximum current
- P Max** - Maximum active power
- P Mean** - Mean active power
- U Max** - Max line voltage (phase-to-phase)
- U Min** - Min line voltage (phase-to-phase)
- Reset** - Reset measurements

15.1.5.4.5 Power factor

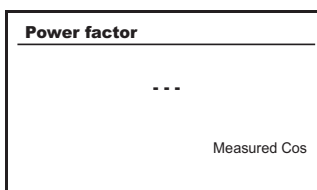

The unit provides the measurement of the global power factor. For phase power under 2% ($0.02 \times P_{n\text{phase}}$) the value is not displayed, but is replaced by '.....'.

Model	L2234		Apparatus	Emax	Scale
			Doc.No.	1SDH000460R0002	Page No. 115/155

15.1.5.4.6 Energy

The unit also provides meter readings of the total active, reactive and apparent energy of the system. The minimum value that can be displayed is 0.001MWh or 0.001MVARh or 0.001MVAh. The energy meters' end of scale is approximately 2.15 billion kWh / kVARh / kVAh. The meter can also be reset by pressing the "Reset meters" key on the menu. For the ranges and precisions see par.14.2.9.15.

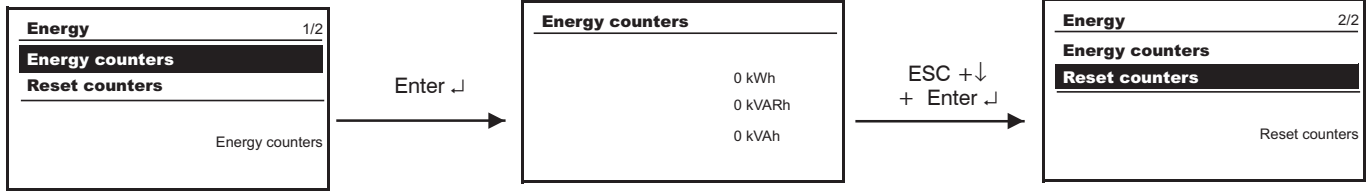

15.1.5.4.7 Peak factor

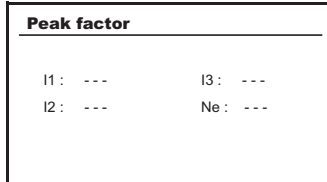

On this page you can also measure the peak factor - i.e. the relationship between I_{peak} / I_{rms} - for each of the phases. This measurement is not displayed for phase currents below $0.3xI_n$ and it is not available for phase currents above $6xI_n$. For the ranges and precisions see par. 14.2.9.15.

15.1.5.4.8 Mains frequency

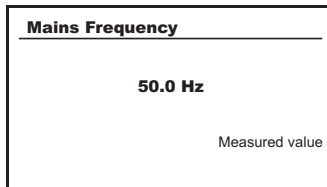

This page enables you to view the mains frequency. This is calculated on the voltages (if $U_{max} > 0.1U_n$). For the ranges and precisions see par. 14.2.9.15. The measurement is guaranteed a maximum of 5 s after the change in frequency.

15.1.5.4.9 Contact wear

This submenu shows the percentage of wear on the CB contacts.

15.1.5.4.10 Waveforms

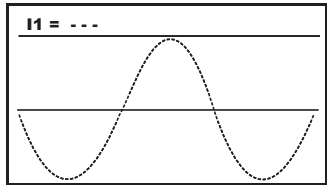

When you access this menu page, 120 samples of the wave form of the selected phase are acquired and displayed. When you press the \downarrow key, a new wave form is acquired and displayed. Using the \uparrow or \downarrow keys, you can display the waveforms of the following measurement channels (L2, L3, Ne, V1, V2, V3, Gt).

Value of harmonic N° N° of currently-selected harmonic

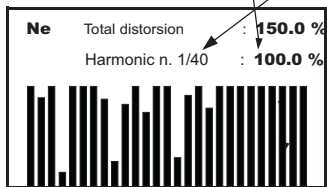

You can analyze the harmonic of the samples acquired and displayed on the "Waveforms" page, i.e. the page on the left is displayed, containing the module of the harmonics from the 1st to the 40th (up to the 35th for a mains frequency set to 60Hz) given as a percentage of the fundamental (harmonic $n^\circ 1$), which is consequently always given as 100%.

Using the \uparrow and \downarrow keys you can go to the bar of interest (at the "No." of harmonic required, the bar begins to flash) and read the corresponding percentage value. The measurement precision is 5%.

15.1.6 Data logger

The data logger is active both with Vaux and with a power supply from the PR120/V. For further information, see par. 16.4.

Model	L2234			Apparatus	Emax	Scale
				Doc.No.	1SDH000460R0002	Page No. 116/155

15.1.7 Electrical characteristics of the transformers

If the phase-to-phase line voltage is greater than 690Vac, it is essential to use a step-down transformer between the bars and the PR120/V module. Voltage transformers can be installed up to 15 m away from the PR120/V module to which they are connected. Proper operation is only guaranteed for star/star or delta/delta configurations. The allowable primary and secondary rated voltages that must be set on the unit are specified in the table 15.1.5.2.

Mechanical characteristics

Fixture	DIN rail EN 50022
Material	self-extinguishing thermoplastic
Degree of protection	IP30
Electrostatic protection	shielded towards EARTH

Electrical characteristics

Precision class	cl. 0.5
Performance	≥ 10 VA
Overload	20% permanent
Insulation	4 kV between inputs and outputs 4 kV between shield and outputs 4 kV between shield and inputs
Operating frequency range	from 50 Hz to 60 Hz, ± 10%

Model	L2234			Apparatus	Emax	Scale
				Doc.No.	1SDH000460R0002	Page No. 117/155

15.2 PR120/D-M - COM communication module

15.2.1 General characteristics

Dedicated communication module for connecting the relay to a Modbus net, and for remote supervisory and control activities on the circuit breakers.

15.2.2 Front view

- "Power" LED
- LED RX/TX (data send/receive signal).

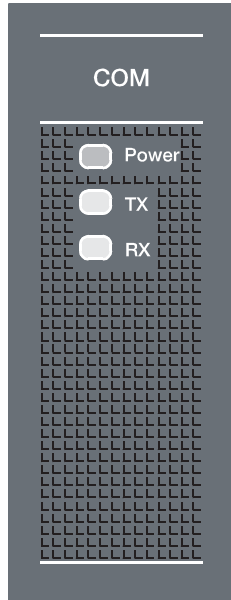

15.2.3 Releases complete with the module

- optional for PR122/P
- optional for PR123/P

15.2.4 Power supply

The PR120/D-M - COM communication module is only powered by the relay if there is a 24V auxiliary voltage available.

15.2.5 Connection

Refer to fig.45 in the wiring diagram provided in this manual.

15.2.6 Communication functions available

The communication function on the PR122/P, PR123/P releases with PR120/D-M - COM is listed in the table:

PR122/P or PR123/P + PR120/D-M - COM

Protocol	Modbus RTU
Physical interface	RS-485
Baud rate	9600 - 19200 bit/s

15.2.7 PR120/D-M - COM module menu

Parameter / Function	Values	Notes
Local/remote	Local/remote	
Serial address	1 ... 247	
Baud rate	9600 bit/s 19200 bit/s	
Physical protocol	8,E1 - 8,0,1 - 8,N,2 - 8,N,1	
Addressing	Modbus standard ABB	

Model	L2234			Apparatus	Emax	Scale
				Doc.No.	1SDH000460R0002	Page No. 118/155

15.3 PR120/K signalling module

15.3.1 General characteristics

The module enables the local signalling of alarms and circuit breaker trips.

There are two possible configurations for the SIGNALLING module:

- default configuration: 1 digital input, 3 contacts with pole in common, 1 independent contact;

- alternative configuration: 4 independent contacts. In this case, the digital input is wired, but not brought up to the terminal block.

The two configurations are alternative to each other. You can switch from one configuration to the other without changing the module, by using a different wiring, as illustrated in the wiring diagrams in figs. 46 or 47.

15.3.2 Front view

- "Power" LED

- N° 4 LED: associated with the signalling contacts.

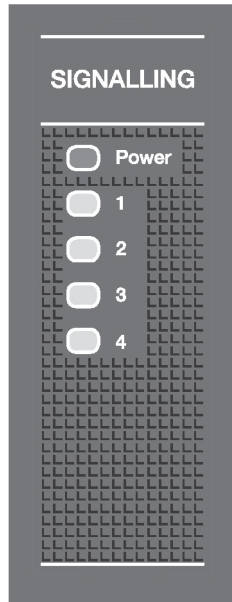

15.3.3 Releases complete with the module

- optional for PR122/P

- optional for PR123/P

15.3.4 Characteristics of the digital input

The unit enables the digital input to be associated with the following functions:

- enabling of an alternative set of parameters, set B (PR123/P only);

- outside trip control;

- zeroing release trips;

- resetting PR120/K contacts;

- local/remote enabling;

- resetting energy meters.

With the digital input the enabling relays have a common connection.

For the load control function, the module can be used as an actuator.

15.3.5 Characteristics of the signalling contacts

The following data are defined for resistive loads ($\cos \varphi = 1$)

Type of contact	SPST	
Maximum switching voltage	130 Vdc	380 Vac
Maximum switching current	5 A	8 A
Maximum switching power	175 W	2000 VA
Breaking capacity @ 35 Vdc	5 A	----
Breaking capacity @ 120 Vdc	0.2 A	----
Breaking capacity @ 250 Vdc	----	8 A
Breaking capacity @ 380 Vdc	----	5.2 A
Contact/coil insulation		4000 Vrms
Contact/contact insulation		1000 Vrms

Model	L2234		Apparatus	Emax	Scale
			Doc.No.	1SDH000460R002	Page No. 119/155

15.3.6 Power supply

The PR120/K signalling module is powered in auxiliary mode by the relay and/or by the PR120/V as specified for the PR120/V module.

15.3.7 PR120/K module menu

Parameter / Function		Values	Notes
Relay n. 1 (K51/p1)	Signal source	Standard or custom	- see par.16.5
	Delay	0...100s step 0.01s	- Deliberate delay before activating the contact
	NO/NC	NO/NC	- Contact normally-open (NO) or normally-closed (NC)
	Latch	ON/OFF	- With the contact "ON", once it has been activated it stays switched A specific reset action is needed to reset it
Relay n. 2 (K51/p2)	Signal source	Standard or custom	as above
	Delay	0...100s step 0.01s	
	NO/NC	NO/NC	
	Latch	ON/OFF	
Relay n. 3 (K51/p3)	Signal source	Standard or custom	as above
	Delay	0...100s step 0.01s	
	NO/NC	NO/NC	
	Latch	ON/OFF	
Relay n. 4 (K51/p4)	Signal source	Standard or custom	as above
	Delay	0...100s step 0.01s	
	NO/NC	NO/NC	
	Latch	ON/OFF	
Input	Polarity	active low active high	
	Function	Generic Outside trip Reset trip Set B Local Signal reset Energy reset Delay	- no associated action - releases the circuit breaker - resets the data after a trip - switches from set A to set B - forces the local status of the protection (local/remote) - programmable contact reset - energy meter reset - performs action after preset time

Model	L2234		Apparatus	Emax	Scale
			Doc.No.	1SDH000460R0002	Page No. 120/155

15.3.8 Programming contacts K51/p1, K51/p2, K51/p3 and K51/p4

The PR120/K is fitted with four relays whose contacts are named K51/p1, K51/p2, K51/p3 and K51/p4, which can signal different situations selectable by the user from among those given in the standard list, whereas customizations can be programmed by selecting "custom" on the menu and setting the signal required with a PDA, SD-Testbus or PR010/T. See Appendix 16.5.

15.3.9 Configurable input

There is an input with a configurable function in the Signalling module. The figure shows two cases, A and B, in which the input's status is active; in case A the input does not stay valid beyond the enabling delay so the associated action does not take place, whereas in case B the action takes place after the preset delay.

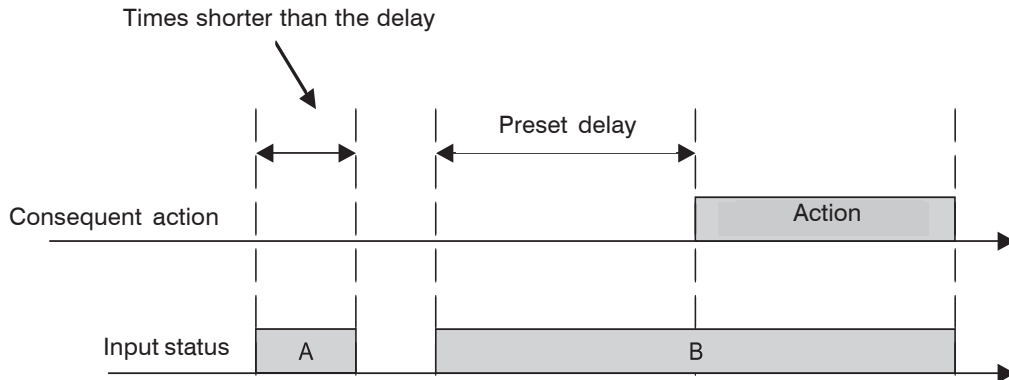

15.3.9.1 Input configuration settings

You can select the level at which to consider the input enabled:

1. low input enabling level
2. high input enabling level

15.3.9.2 Input function settings (ACTION)

You can select the action associated with the input, i.e. the action that takes place after the programmed delay, when the input is enabled (on high or low level).

You can select one of the following actions:

1. Generic: no specific action is associated with the input. The status of the input is shown on the available display and remotely via the bus
2. Trip test: when the input is enabled for the specified delay, a trip test is performed
3. Trip reset: when the input is enabled for the specified delay a trip reset is performed
4. Set B: when the input is enabled for the specified delay, the Set B is enabled
5. Dial Local: when the input is enabled for the specified delay, there is a forcing of the dialogue local mode
6. Signalling module reset: when the input is enabled for the specified delay, the status of the relays in the PR120/K module is reset
7. Energy reset: when the input is active for the specified delay, the energy meters are reset.

15.3.9.3 Setting the input enabling delay

By means of the "Delay" parameter, you can specify the time elapsing before the input is enabled in the range 0.00 [s] to 100.00 [s] with 0.01[s] steps.

Model	L2234		Apparatus	Emax	Scale
			Doc.No.	1SDH000460R0002	Page No. 121/155

15.3.10 PR120/K module menu layout

The menu layout relating to relay n. 1 (K51/p1) is shown below as an example; the same applies to the menus for the other relays.

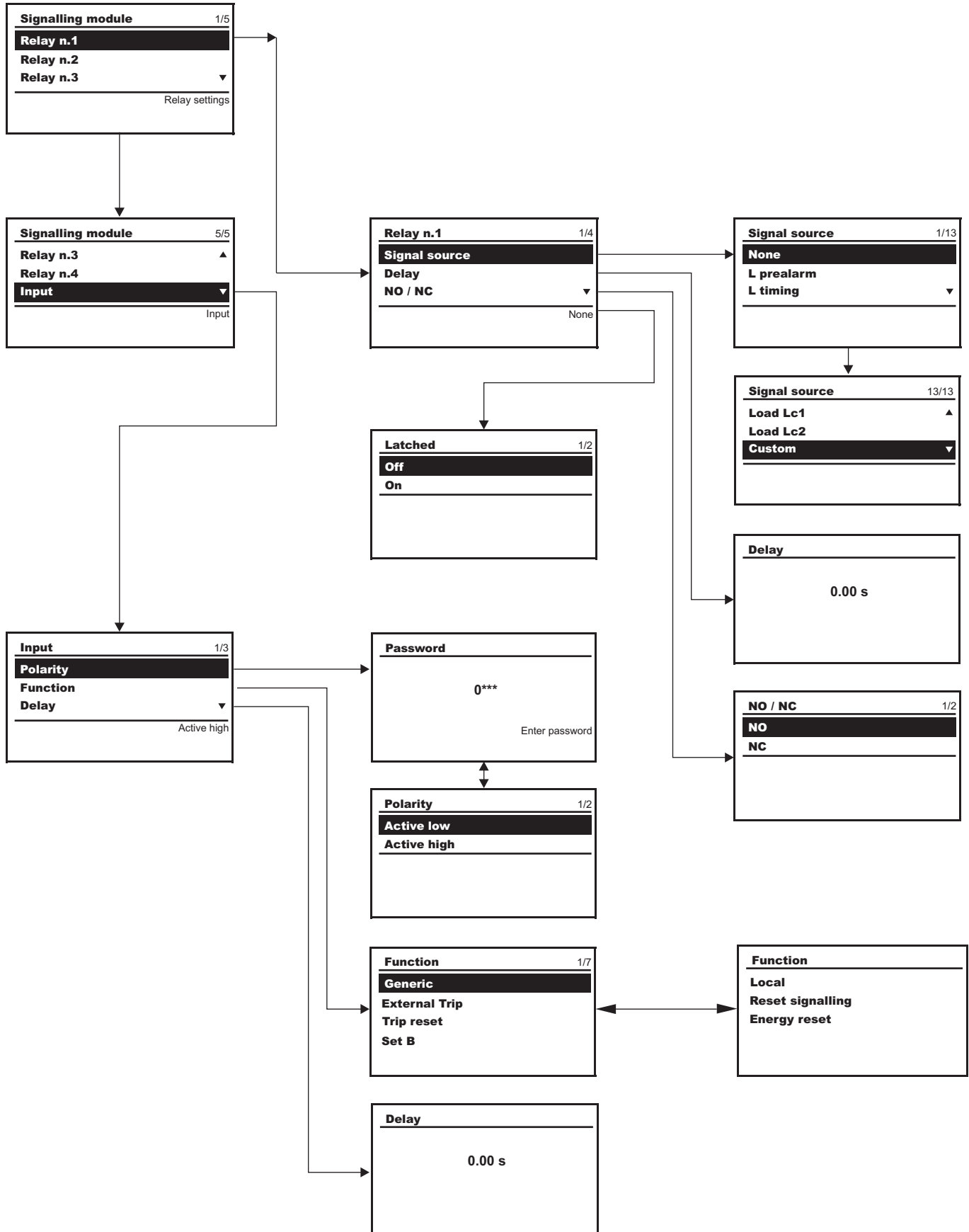

Model	L2234			Apparatus	Emax	Scale
				Doc.No.	1SDH000460R0002	Page No. 122/155

15.4 PR120/D-BT - WL-COM wireless communication module

15.4.1 General characteristics

This module enables wireless communication between the protection releases and a handheld PC (PDA) or a laptop with a Bluetooth port. The module is designed specifically for use with the SD-Pocket application.

15.4.2 Front view

- "Power" LED
- LED Rx/Tx (send/receive signal)
- LED BT (Bluetooth link enabled)

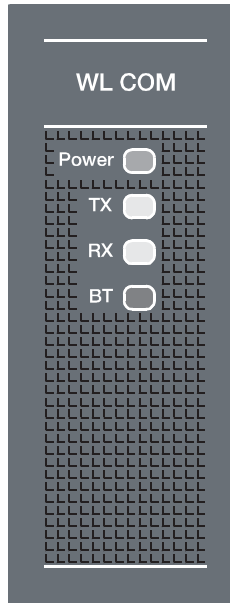

15.4.3 Releases complete with the module

- optional for PR122/P
- optional for PR123/P

15.4.4 Power supply

The PR120/D-BT WL-COM module is powered in auxiliary mode, from the PR120/V module, as specified in the description of the module, or by a PR030/B power supply unit.

15.4.5 Connection

For a proper connection, bear in mind that the module's range of action is 10 meters in air.

Model	L2234			Apparatus	Emax	Scale
				Doc.No.	1SDH000460R0002	Page No. 123/155

16 Appendices

16.1 PR021/K outside signalling unit

16.1.1 General information

The signalling unit converts the digital signals provided by the protection units into electrical signals by means of normally-open electric contacts. Information on the status of the protection functions transmits on a dedicated serial line connected to the release.

The following signals/contacts are available:

- L overload prealarm (the alarm signal remains enabled throughout the overload, until the release has been tripped)
- protections timing and trip (the protections trip signal remains enabled during the timing-controlled phase and after the release has been tripped)
- I protection trip
- timing and overheating threshold overrun
- two contacts for load control
- release trip
- communication error on serial line (connections between protection and signalling units)
- phase unbalance.

By setting the DIP switches, you can configure the signals of 7 programmable contacts. This can be done by selecting them directly in the PR122/P or PR123/P relay, choosing from a long list, including: directional protection trip D, minimum and maximum voltage trip UV and OV, reverse power trip RP and others.

Two contacts available on the SACE PR021/K (load control) unit enable you to control a release for opening and closing the circuit breaker. These contacts enable various applications, including load control, alarms, signals, electric cutouts.

A Reset button enables you to zero the status of all the front optical signals and return the relays' contacts to the resting position.

The unit also contains ten LEDs to display the following information:

- Power ON: auxiliary power supply on
- Tx(int Bus): flashing synchronized with dialogue with the Internal Bus
- Eight LEDs associated with the signaling contacts

16.1.2 Power supply

Auxiliary power supply	24 V DC +/-20%
Maximum ripple	5%
Rated power @ 24V	4.4 W

16.1.3 General characteristics of the signalling relays

The following data are defined for resistive loads ($\cos \varphi = 1$)

Type of contact	SPST	
Maximum switching voltage	130 Vdc	380 Vac
Maximum switching current	5 A	8 A
Maximum switching power	175 W	2000 VA
Breaking capacity @ 35 Vdc	5 A	----
Breaking capacity @ 120 Vdc	0.2 A	----
Breaking capacity @ 250 Vdc	----	8 A
Breaking capacity @ 380 Vdc	----	5.2 A
Contact/coil insulation		4000 Vrms
Contact/contact insulation		1000 Vrms

16.1.4 Relay functions

The available contacts can be used to manage the respective relays indicating an event (a given situation in the state of the device) that prompts the required relays to be independently enabled after the delay specified by the user. The function is entirely similar to the one described in the PR120/K signalling module in par. 15.3 and 16.5 of this manual.

16.1.5 PR021/K signalling unit menu

The unit's functions are accessible from the operator panel (PR123/P and PR122/P where applicable)

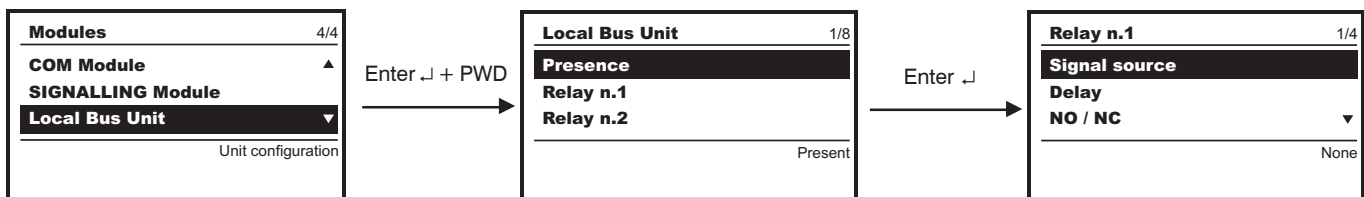

Model	L2234		Apparatus	Emax	Scale
			Doc.No.	1SDH000460R0002	Page No. 124/155

16.1.5.1 PR021/K unit menu table

Protection	Parameter / Function	Values	Notes
PR021K unit		Present Absent	Leave as Absent if there is no PR021/K
	Relay n. 1 / 2 / 3 / 4 / 6 / 7 / 8 Signal source function	None L Prealarm L Timing S Timing L Trip S Trip G Trip I Trip Any trip Custom	
	Delay NO/NC	0...100s step 0.01s NO/NC	- Deliberate delay before activating the contact - Contact normally-open (NO) or normally-closed (NC)
	Latch	ON/OFF	- With the contact "ON", once it has been activated it stays switched A specific reset action is needed to reset it

16.1.5.2 Important note



The unit must be connected to the PR122/P or PR123/P by means of an internal busbar with a shielded, corded two-wire cable (see note A, par. 11.2.2) no more than 15m long. The shield must be earthed both on the circuit breaker side and on the PR021/K side. For the installation and operation of the PR021/K accessory, refer to the specific user manual.

Model	L2234		Apparatus	Emax	Scale
			Doc.No.	1SDH000460R0002	Page No. 125/155

16.2 SD-Pocket

SD-Pocket is a software application designed to connect the new releases to a handheld (PDA) or laptop PC to use wireless communication for communicating with the PR121/P, PR122/P and PR123/P specifically for:

- configuring the protection thresholds (PR122/P - PR123/P)
- viewing the measurements, including the data stored in the data logger of the PR122/P/PR123 releases
- checking the conditions of the circuit breaker (e.g., status, number of maneuvers, fault data, etc., depending on the release in question).

The scenarios for using SD-Pocket include:

- during commissioning, for a rapid and error-free transfer of the protection settings to the releases (also using the files for exchanging data directly from Docwin)
- during the normal operation of the equipment, for collecting information on the circuit breakers and the related loads (fault data, currents measured and other data).

SD-Pocket requires a PDA with MS Windows Mobile 2003 and a Bluetooth interface, or a PC with MS Windows 2000 OS. The releases must be complete with a PR120/D-BT WL or BT030 Bluetooth interface. It is not necessary, however, to have a PR120/D-M communication module. SD-Pocket is distributed free of charge (freeware) and can be downloaded from the BOL site (<http://bol.it.abb.com>).

16.3 SD-Testbus

SD-TestBus is the installation and diagnostic software for ABB SACE products with a Modbus RTU communication. It can be used during commissioning, or to find faults in an already up and running communication network.

This enables the connection to a PR121/P, PR122/P and PR123/P.

SD-TestBus runs an automatic scan on the RS-485 bus, recording all the devices connected and checking their configurations, and also testing all the possible combinations of addresses, parity and baud rate.

With a simple click on SCAN you can pinpoint the devices that fail to respond, the configuration errors, the wrong addresses and parity errors, and so on.

After scanning, the software shows warning messages on potential problems or configuration errors, enabling a complete diagnosis of the communication network. These functions are not limited to the ABB SACE devices: any apparatus using the Modbus RTU standard protocol is recorded and tested.

For the ABB SACE circuit breakers with an electronic release, the software provides a vast range of additional functions, for checking the wiring, setting opening, closing or reset commands, and reading diagnostic information.

This program is so easy to use that it guarantees a trouble-free installation and commissioning of a Modbus communication network.

SD-TestBus is distributed free of charge (freeware) and can be downloaded from the BOL site (<http://bol.it.abb.com>).

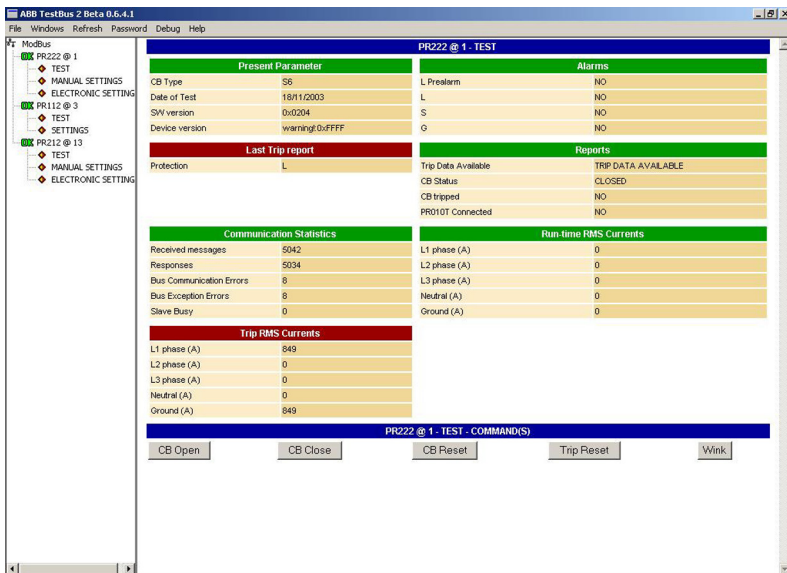

Model	L2234		Apparatus	Emax	Scale
			Doc.No.	1SDH000460R0002	Page No. 126/155

16.4 Data logger (recorder)

The data logger function is available on the PR122/P and PR123/P units and it can be used to save the instantaneous values of certain analog and digital measurements automatically in a large-sized memory buffer. The data can easily be downloaded from the unit using either the SD-Pocket application with a Bluetooth port, or the SD-TestBus application via a Modbus bus, and transferred to any personal computer for processing. The function stops the recording every time a trip occurs in order to facilitate failure analysis.

16.4.1 General characteristics:

Number of analogue channels:	8
Number of digital events:	64
Maximum sampling frequency:	4800 Hz
Maximum sampling time:	27s (- sampling frequency 600 Hz)

16.4.2 Description of the data logger menu

You can access the data logger menu from the Settings menu in the PR122/P and PR123/P units:

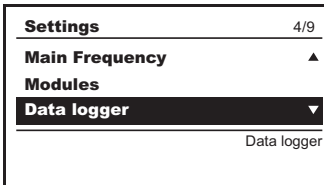

16.4.2.1 Enabling the data logger

The data logger can be enabled by inputting a password:

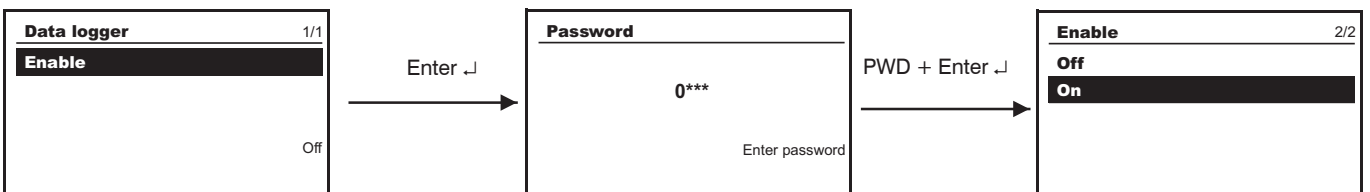

16.4.2.2 Setting the sampling frequency

On the menu, you can specify the frequency with which the measurements are saved, choosing from 4 fixed frequencies, i.e. 600Hz, 1200Hz, 2400Hz or 4800Hz.

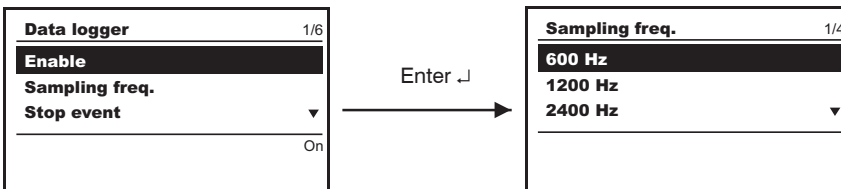

The maximum data recording times (see also par. 16.4.3) depend on the selected frequency and are illustrated in the following table:

Frequency	RECORDING TIME
600 Hz	27.3 s
1200 Hz	13.6 s
2400 Hz	6.8 s
4800 Hz	3.4 s

16.4.2.3 Setting the standard stop events (triggers)

You can select one of the following stop events (triggers), see also par.16.5.2:

1. None
2. Any alarm
3. L timing
4. Any trip

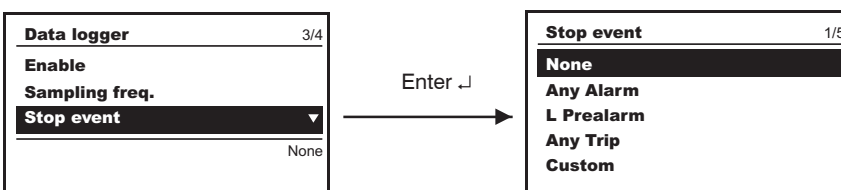

Model	L2234		Apparatus	Emax	Scale
			Doc.No.	1SDH000460R002	Page No. 127/155

If you select "None" for the stop event, the data logger can be stopped only by a stop command from the operator panel, from the system or following a trip generated by the relay.

16.4.2.4 Setting and viewing customized stop events (triggers)

From the system, you can set customized stop events (triggers) to coincide with the events shown in paragraph 16.5. In the event of a customized trigger point, the following window is displayed:

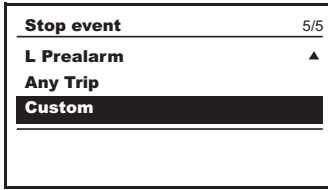

16.4.2.5 Setting the stopping delay

The stopping delay can be set between 0.00 [s] and 10.00 [s], in 0.01 [s] steps.

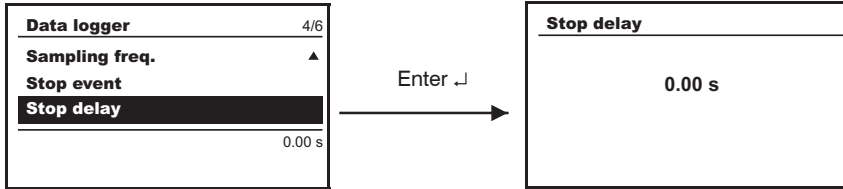

In the event of a trip, this data storage process is stopped after 10 ms, even if a longer stopping delay has been selected.

16.4.2.6 Restart/Stop data logger

Using the Restart/Stop options, you can restart or stop the recording by the data logger:

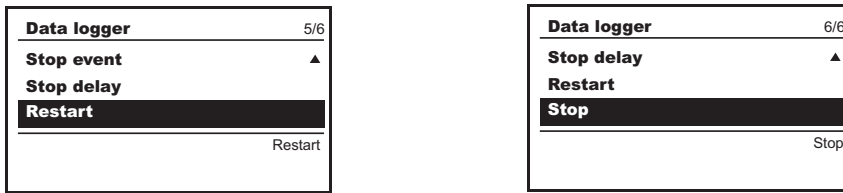

16.4.3 Recording time windows

The data logger's measurements are recorded in a time window, the duration of which is defined and synchronized by an event (trigger/stop event) of your choice.

The following figure displays the time window, the trigger and the samples available in gray:

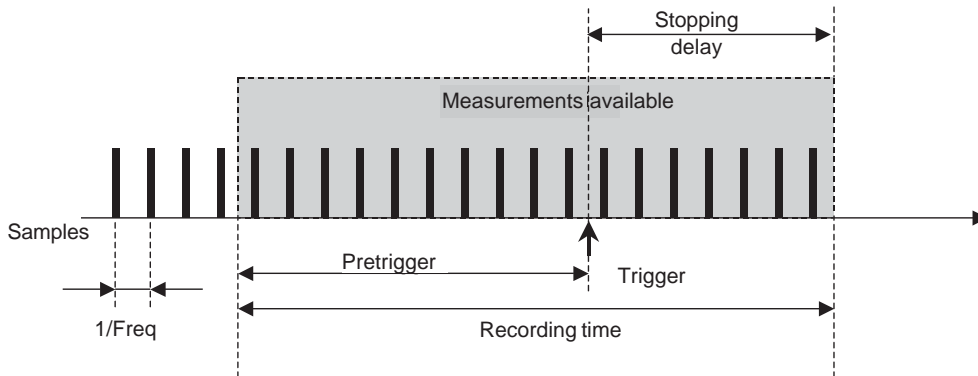

The user can select the sampling frequency (see par.16.4.2.2), the type of stop event (trigger) (see par.16.4.2.3) and the stopping delay (see par.16.4.2.4) so as to obtain the required pre-trigger with respect to the selected event.

Depending on the selection you make, the stopping delay may be nil, or it may be lower or higher than the recording time, as illustrated in the following figure:

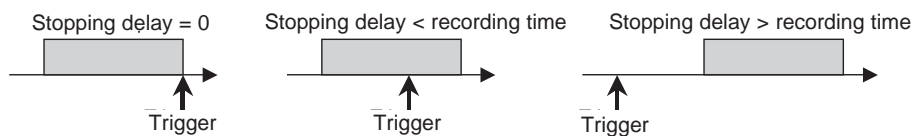

Model	L2234			Apparatus	Emax	Scale
				Doc.No.	1SDH000460R0002	Page No. 128/155

The maximum recording time is determined exclusively by the sampling frequency, established as shown in the table in par. 16.4.2.2. If the sum of the stopping delay plus the time elapsing between a restart trigger and a trigger is less than the maximum recording time, then the recording time will be shorter than the maximum, as illustrated in the following figure:

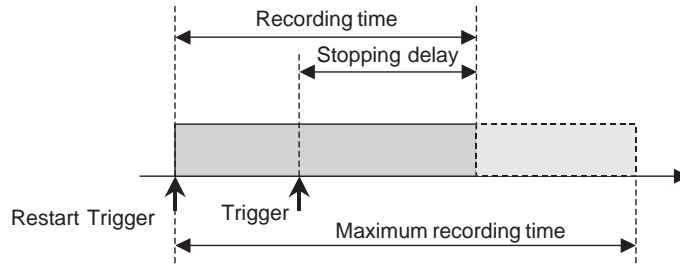

If the parameters relating to the data logger are changed while it is operating, the recording underway is terminated and a new recording begins (after a restart trigger command) on the basis of the new parameters.

16.4.4 Description of the information given by the data logger system

16.4.4.1 Combination of devices for reading/setting data from the data logger system

By connecting to the release's outside bus, you can set certain data logger parameters, triggers or commands, or read certain types and sequences of data in its memory.

The combinations of devices and the consequent software combinations that enables these functions are as follows:

- 1) PR122/P + BT030+SD-Pocket
- 2) PR122/P + PR120/D-M + SD-Testbus or remote system
- 3) PR122/P + PR120/D-BT + SD-Pocket
- 4) PR123/P + BT030+SD-Pocket
- 5) PR123/P + PR120/D-M + SD-Testbus or remote system
- 6) PR123/P + PR120/D-BT + SD-Pocket
- 7) PR122/P + PR010/T *
- 8) PR123/P + PR010/T *

* With these combinations it is impossible to download sequences of stored data

In this manual, the term "from the system" is used to define both the operations that are carried out using one of the combinations with SD-Pocket or SD-Testbus, and the operations that involve connecting to a remote system.

16.4.4.2 Access to saved data from the system

When the event associated with the stop event occurs or a stop command is received, the following data are saved in the recording block:

- Data logger Trigger, which indicates the type of stop event (trigger) that has prompted the stoppage of the data logger;
- Time-stamp of the stop event (trigger) (day/hour + minutes/seconds/milliseconds)(4 words);
- Data logger max file, which indicates which is the max file with consistent data;
- Data logger max address, which indicates the max address number of a block with consistent data.

The following information is recorded in the block for each sampling period:

1. current sample L1
2. current sample L2
3. current sample L3
4. current sample Ne
5. External ground current sample
6. voltage sample U12
7. voltage sample U23
8. voltage sample U31
9. digital inputs / outputs (among 16 possible options, e.g. inputs/outputs for Zone Selectivity, PR120/K contact status, ...)
10. alarms1 (among 16 possible options, e.g. L timing, G alarm, Prealarm)
11. alarms2 (among 16 possible options, e.g. UF timing, OV timing, Frequency error, RP timing)
12. trip (among 16 possible options, e.g. tripping of L, S, I, G, UV, OF, ...)

Model	L2234		Apparatus	Emax	Scale
			Doc.No.	1SDH000460R0002	Page No. 129/155

16.4.4.3 Information from the system on the configuration and status of the data logger

The following information is provided on the status of the data logger:

STATUS	
Waiting trigger:	this means that the data logger is enabled and waiting for the occurrence of the event selected as the trigger
Data logger triggered:	this indicates that the trigger event has occurred and the data logger is still recording
Data logger stopped:	this means that the recording has been terminated either because it has been completed or because a data logger stop command has been received, or because a trip has occurred

CONFIGURATION	
Data logger config:	indicates whether or not the data logger is active
Data logger trigger type:	indicates the stop event (trigger) setting
Data logger stopping delay:	indicates the delay for the stop

16.4.5 Data logger commands from the system

When a data logger stop command is given, the recording is stopped from the system. The subsequent recording is enabled by a Restart trigger command. The same applies to the operator panel, as illustrated in par. 16.4.2.6.

Example of data logger operation

The following figure shows an example of how a trigger works, the data logger's function, the effect of the stopping delay and of the restart and subsequent stop commands on the data saving procedure.

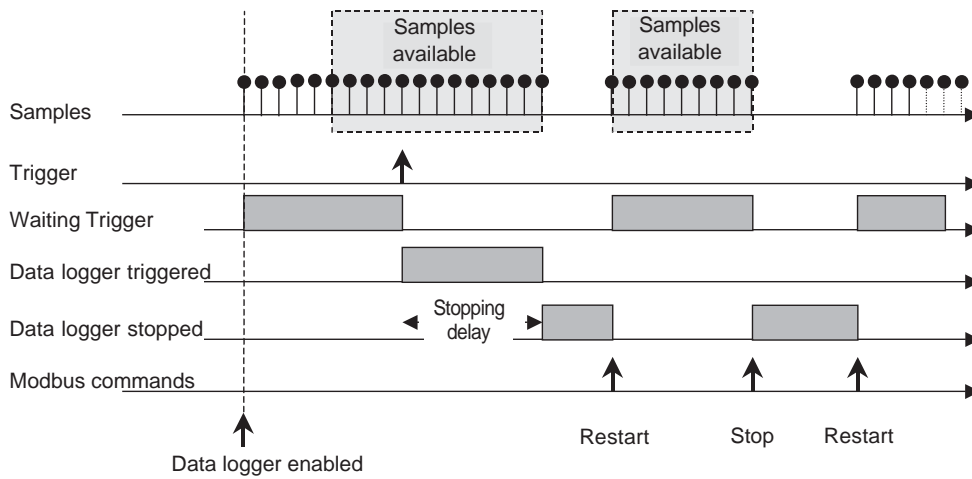

Model	L2234			Apparatus	Emax	Scale
				Doc.No.	1SDH000460R0002	Page No. 130/155

16.5 Table showing list of events

16.5.1 "Standard" events for PR120/K and for PR021/K selectable from the relay:

Event n.	Description	
0.	None	(none enabled)
1.	L prealarm	(L protection prealarm)
2.	L timing	(L protection timing)
3.	S timing	(S protection timing)
4.	L trip	(L protection trip)
5.	S trip	(S protection trip)
6.	I trip	(I protection trip)
7.	G trip	(G protection trip)
8.	Any trip	(tripping of any protection)

16.5.2 "Standard" events for the data logger function, selectable from the relay:

Event n.	Description	
0.	None	(free running)
1.	Any alarm	(any alarm)
2.	L timing	(L protection timing)
3.	Any trip	(tripping of any protection)

16.5.3 "Custom" events for the data logger function, for PR120/K and PR021/K:

N. (decimal)	Event	Notes	PR122	PR123
1920	G timing		x	x
2894	L1 or L2 or L3 sensor error or Trip Coil error		x	x
2688	LC1 alarm		x	x
2049	G alarm		x	x
2306	UV timing		x	x
4124	UV or OV or RV tripped		x	x
33672	CB connected and springs loaded		x	x
1793	Harmonic distortion > 2.1		x	x

You can combine the status bits with "and" / "or" logical functions within the same group of events (byte). For more detailed information, refer to the Modbus Interface document.

16.5.4 Combining the devices needed to customize settings

The "custom" events can be selected using a remote control system, SD-Pocket, or SD-TestBus. The devices you need to enable you to do so can be selected from among the following:

- 1) PR122/P + BT030 + SD-Pocket
- 2) PR122/P + PR120/D-M + SD-Testbus or remote system
- 3) PR122/P + PR120/D-BT + SD-Pocket
- 4) PR122/P + PR010/T
- 5) PR123/P + BT030 + SD-Pocket
- 6) PR123/P + PR120/D-M + SD-Testbus or remote system
- 7) PR123/P + PR120/D-BT + SD- Pocket
- 8) PR123/P + PR010/T

Model	L2234		Apparatus	Emax	Scale
			Doc.No.	1SDH000460R0002	Page No. 131/155

17. Overall dimensions

Fixed circuit-breaker

Basic version with horizontal rear terminals

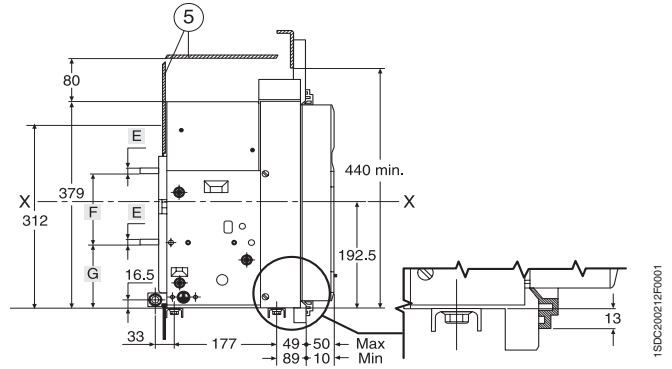
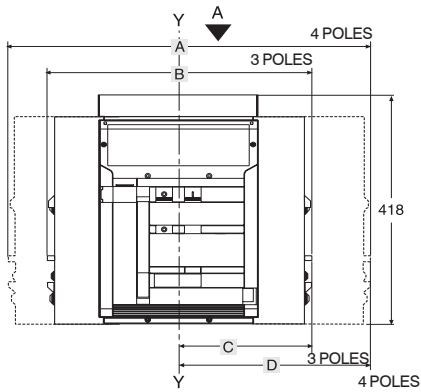

Legend

- ① Inside edge of compartment door
- ② Segregation (where foreseen)
- ③ Circuit-breaker M10 fixing drilling (use M10 screws)
- ④ N° 1 M12 screw (E1, E2, E3) or n° 2 M12 screws (E4, E6) for earthing (included in the supply)
- ⑤ Insulating or metal-insulated wall

E1/E2
View A

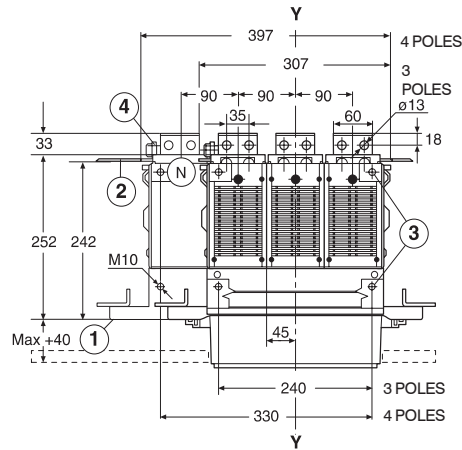

E3
View A

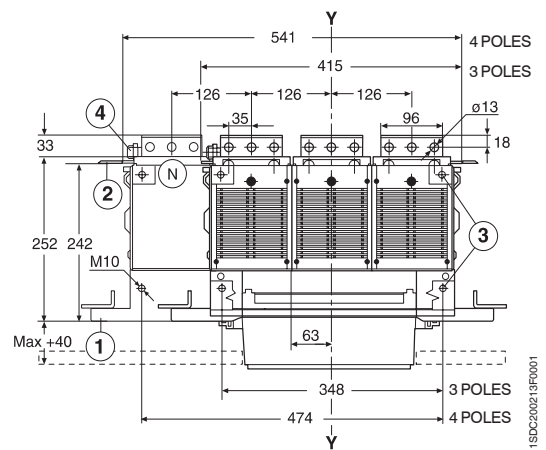

	A	B	C	D	E	F	G
E1	386	296	148	148	10	130	117,5
E2	386	296	148	148	26	114	117,5
E3	530	404	202	202	26	114	117,5
E4	656	566	238	328	26	166	91,5
E4/f	746	-	-	328	26	166	91,5
E6	908	782	328	454	26	166	91,5
E6/f	1034	-	-	454	26	166	91,5

Mod.	L2234			Apparecchio	Emax	Scala
				N° Doc.	1SDH000460R0002	N° Pag. 132/155

Fixed circuit-breaker

Basic version with horizontal rear terminals

E4
View A

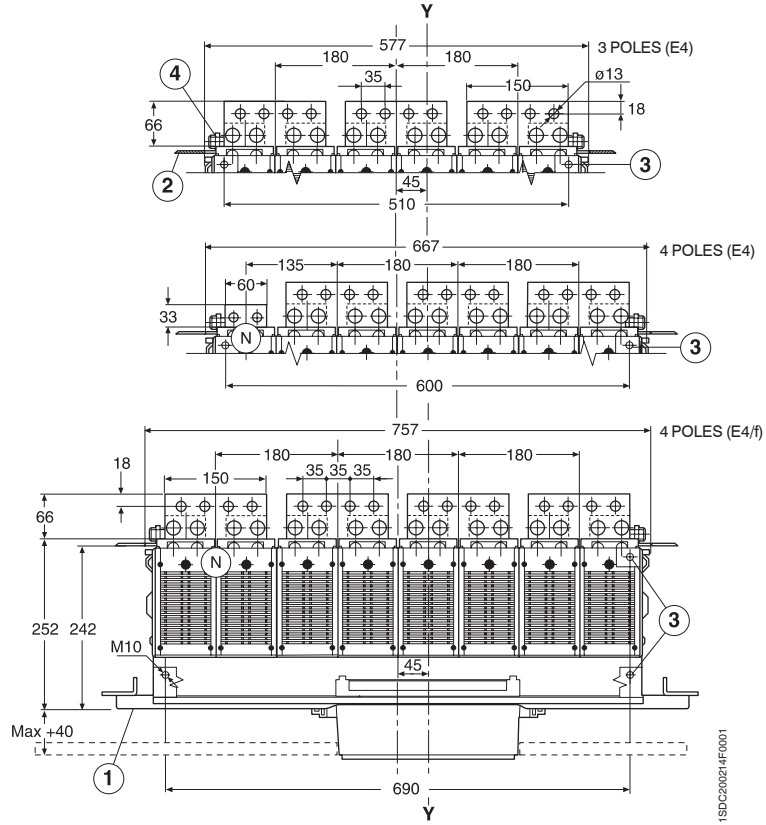

E6
View A

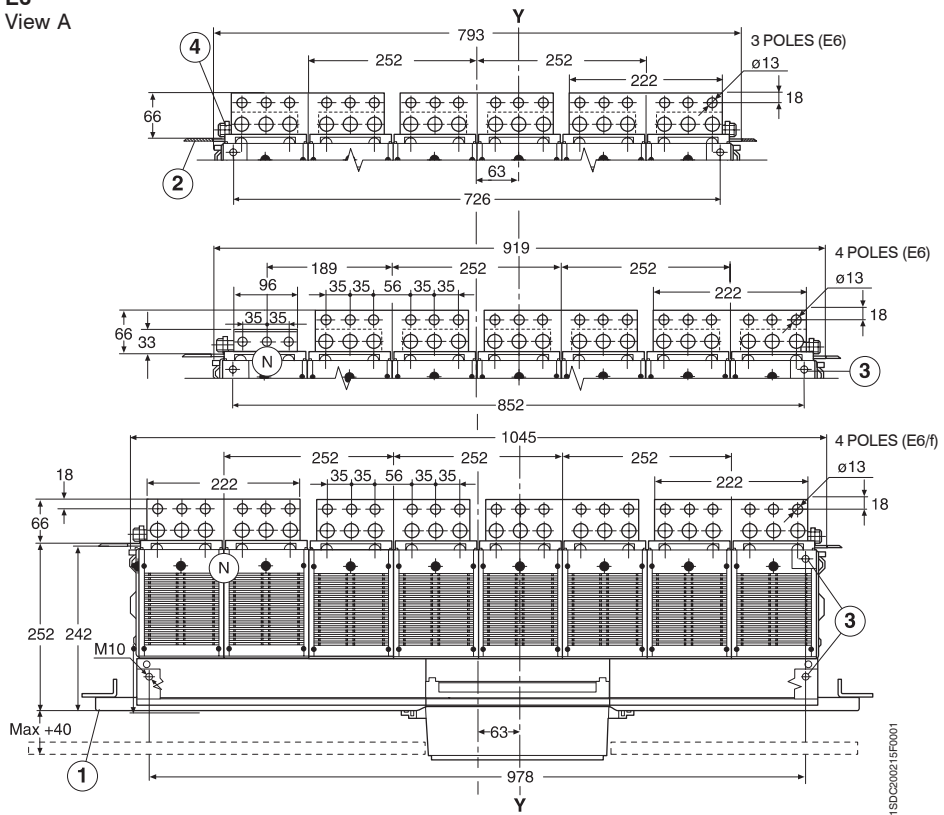

Fig. 36

Mod.	L2234		Apparecchio	Emax	Scala
			N° Doc.	1SDH000460R002	N° Pag. 133/155

Fixed circuit-breaker

Basic version with vertical rear terminals

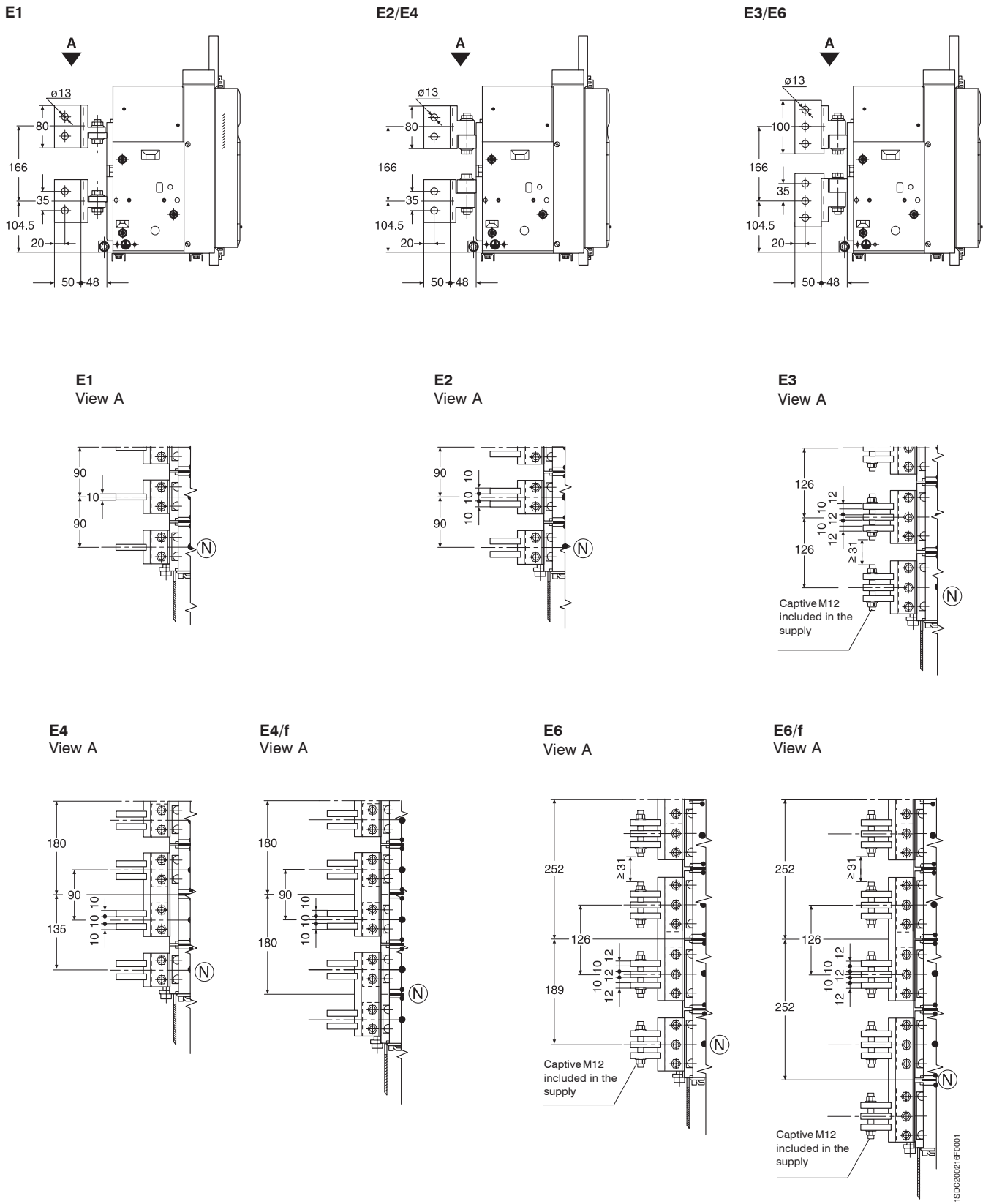

Fig. 36a

Mod.	L2234		Apparecchio	Emax	Scala
			N° Doc.	1SDH000460R0002	N° Pag. 134/155

1SD2200210F0001

Fixed circuit-breaker

Basic version with front terminals

E1

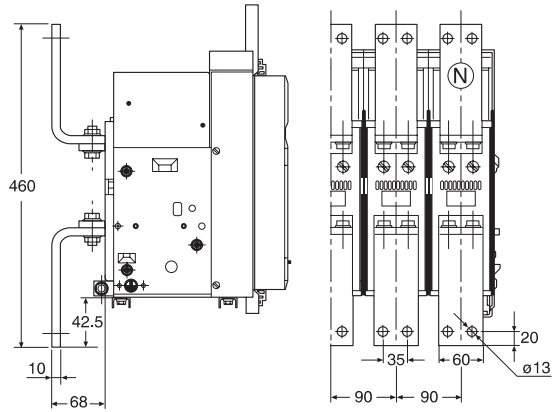

E2

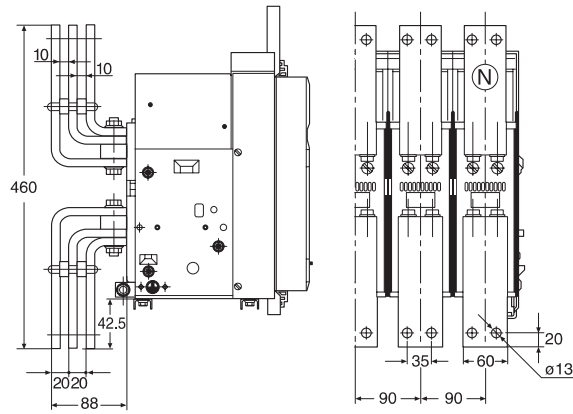

E3

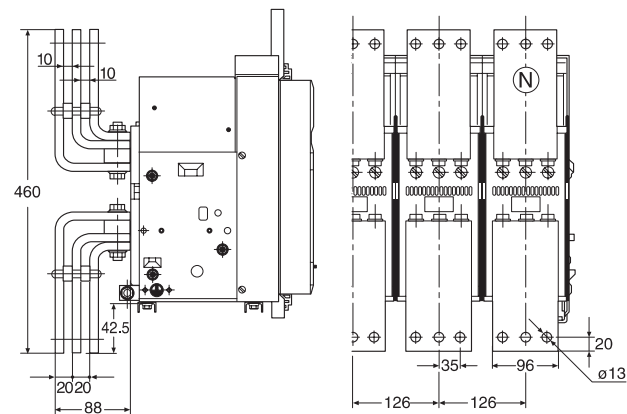

1SDC20027F0001

Fig. 37

Mod.	L2234		Apparecchio	Emax	Scala
			N° Doc.	1SDH000460R002	N° Pag. 135/155

Fixed circuit-breaker

Basic version with front terminals

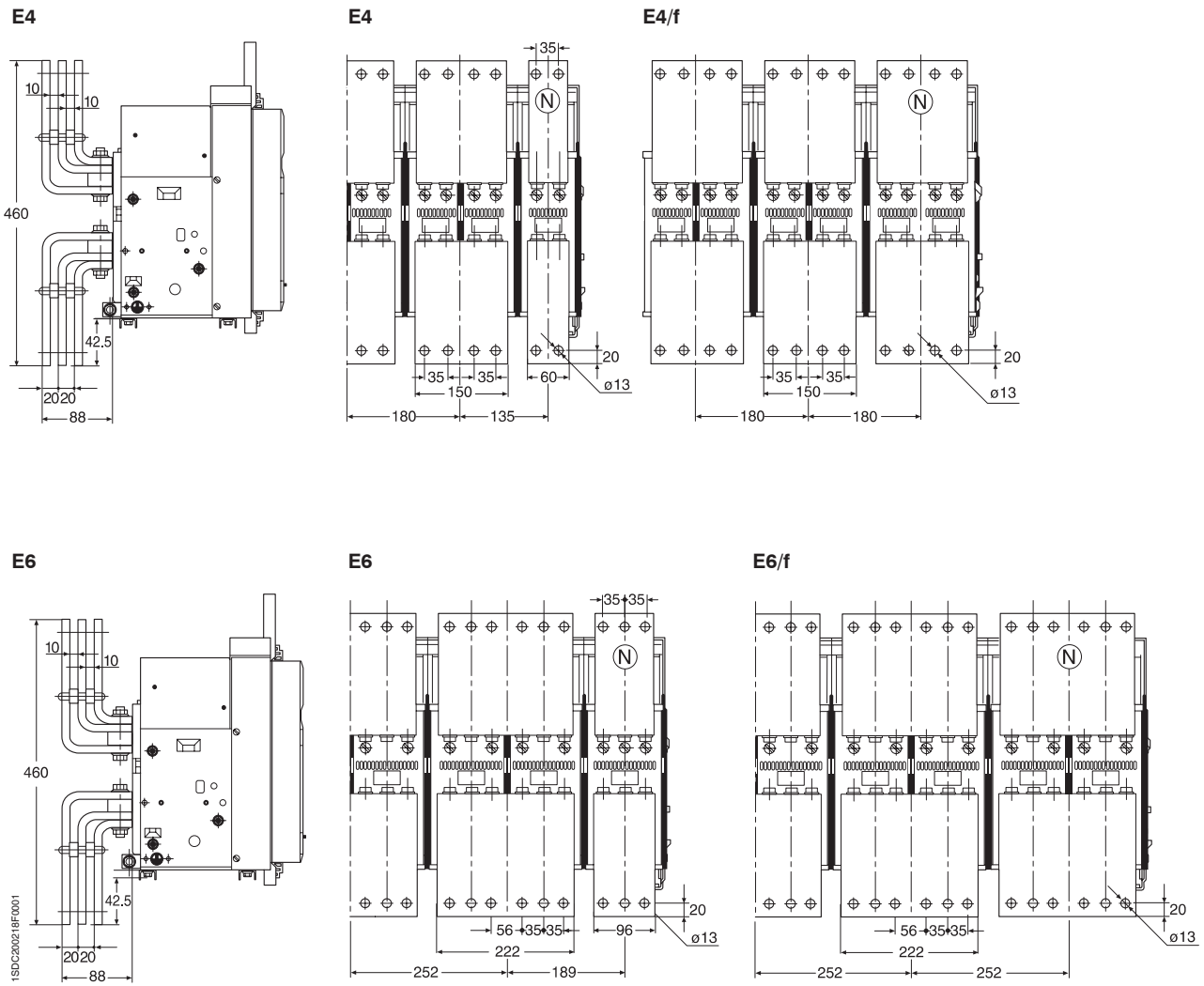
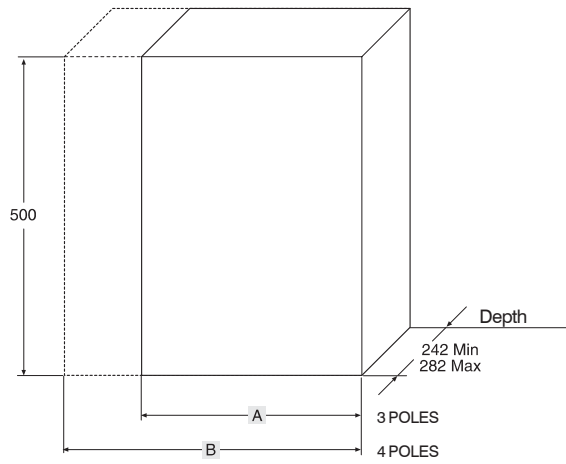

Fig. 38

Mod.	L2234		Apparecchio	Emax	Scala
			N° Doc.	1SDH000460R0002	N° Pag. 136/155

Compartment dimensions



Compartment door drilling

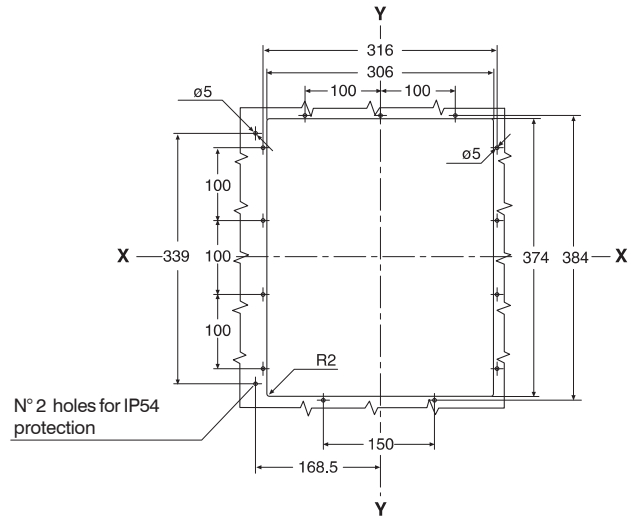

Holes for passing through flexible cables for mechanical interlocks

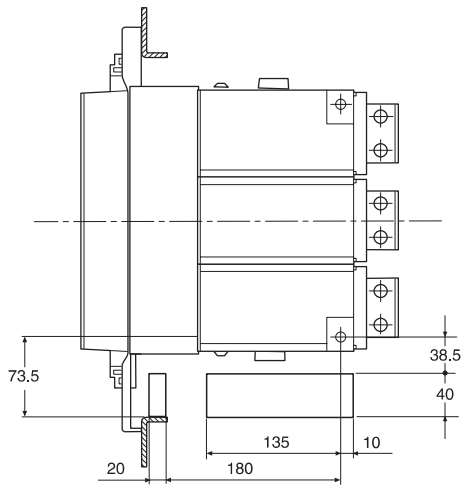

Tightening torque of the main terminals: Nm 70
Tightening torque of the earthing screw: Nm 70

	High resistance M12 screw Quantity per terminal	
	PHASE	NEUTRAL
E1-E2	2	2
E3	3	3
E4-E4/f	4	2-4
E6-E6/f	6	3-6

	A	B
E1	400	490
E2	400	490
E3	500	630
E4	700	790
E4/f	-	880
E6	1000	1130
E6/f	-	1260

Fig. 39

Mod.	L2234		Apparecchio	Emax	Scala
			N° Doc.	1SDH000460R002	N° Pag. 137/155

Withdrawable circuit-breaker

Basic version with horizontal rear terminals

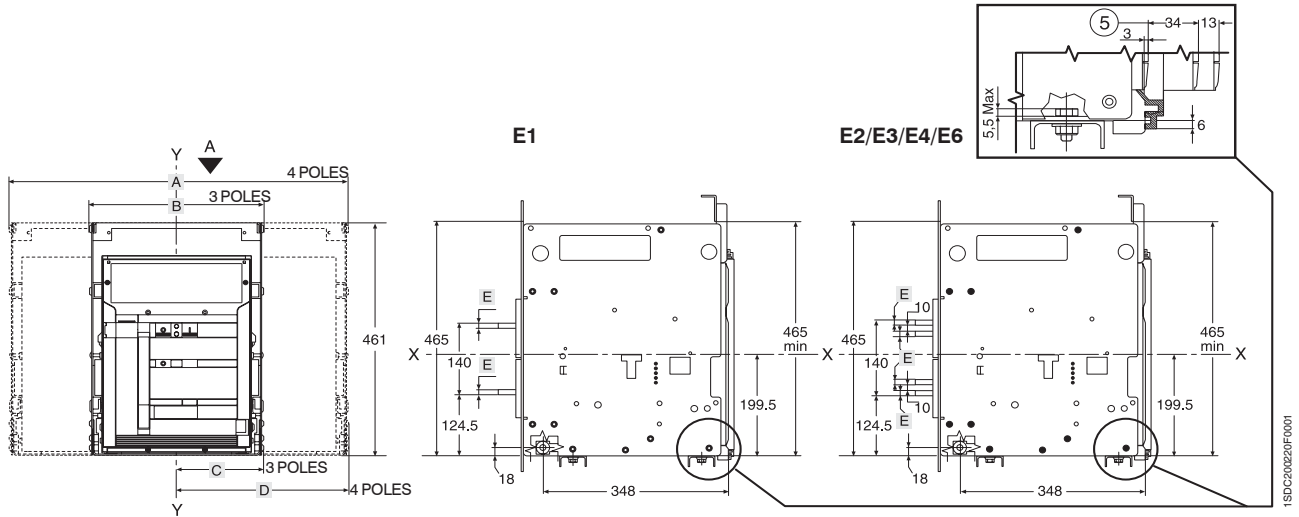

Legend

- ① Inside edge of compartment room
- ② Segregation (where foreseen)
- ③ Fixing fixed part $\varnothing 10$ drilling (use M8 screws)
- ④ N° 1 M12 screw (E1, E2, E3) or n° 2 M12 screws (E4, E6) for earthing (included in the supply)
- ⑤ Run from connected for a TEST to isolated
- ⑥ Alternative drilling with 25 mm pitch for fixing fixed part
- ⑦ Ventilation drilling on the switchgear

E1/E2 View A

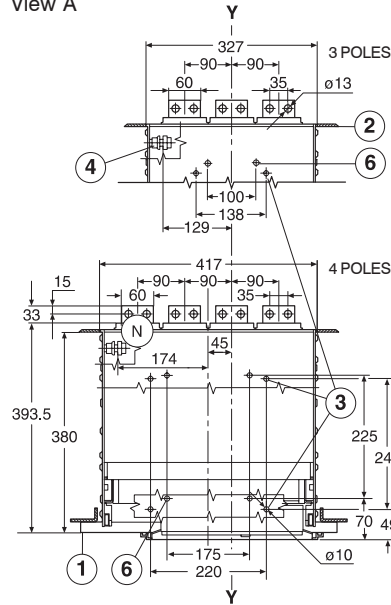

E3 View A

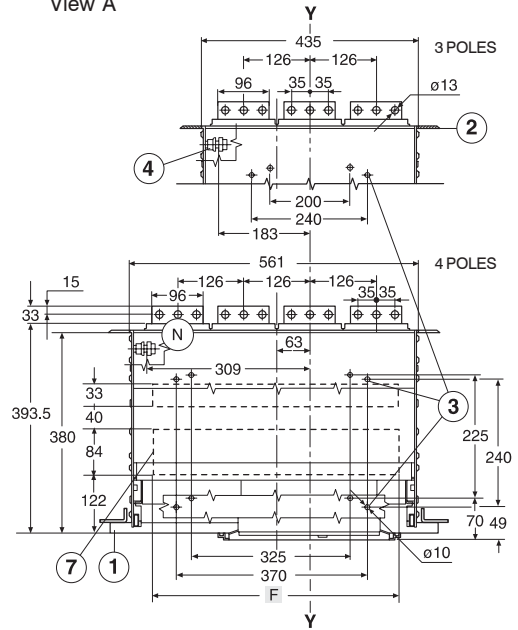

	A	B	C	D	E	F	
						3 poles	4 poles
E1	414	324	162	162	10	-	-
E2	414	324	162	162	8	-	-
E3	558	432	216	216	8	370	490
E4	684	594	252	342	8	530	610
E4/f	774	-	-	342	8	-	700
E6	936	810	342	468	8	750	870
E6/f	1062	-	-	468	8	-	1000

Fig. 40

Mod.	L2234		Apparecchio	Emax	Scala
			N° Doc.	1SDH000460R0002	N° Pag. 138/155

Withdrawable circuit-breaker

Basic version with vertical rear terminals

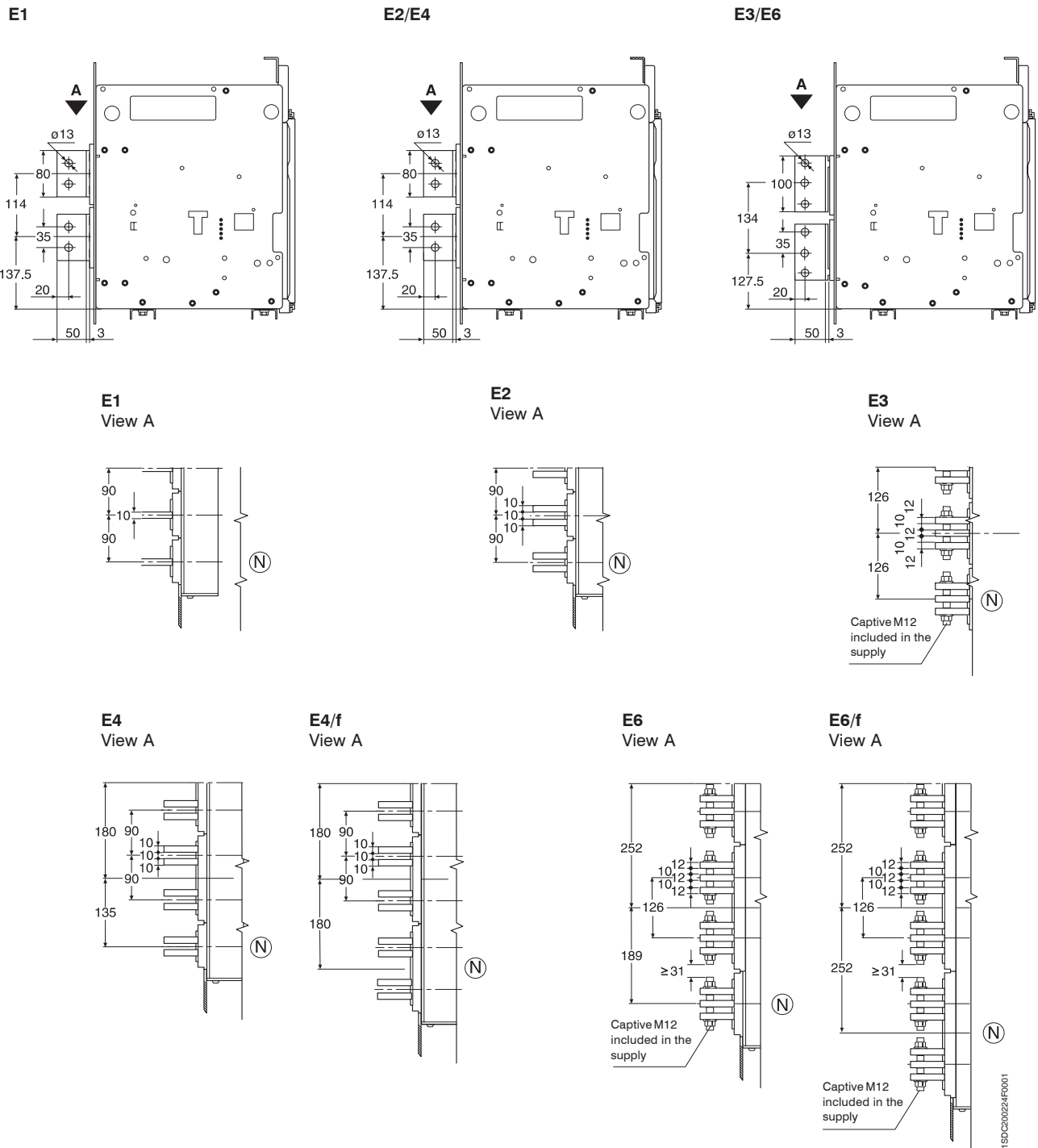

Fig. 42

Mod.	L2234		Apparecchio	Emax	Scala
			N° Doc.	1SDH000460R0002	N° Pag. 140/155

Withdrawable circuit-breaker

Version with front terminals

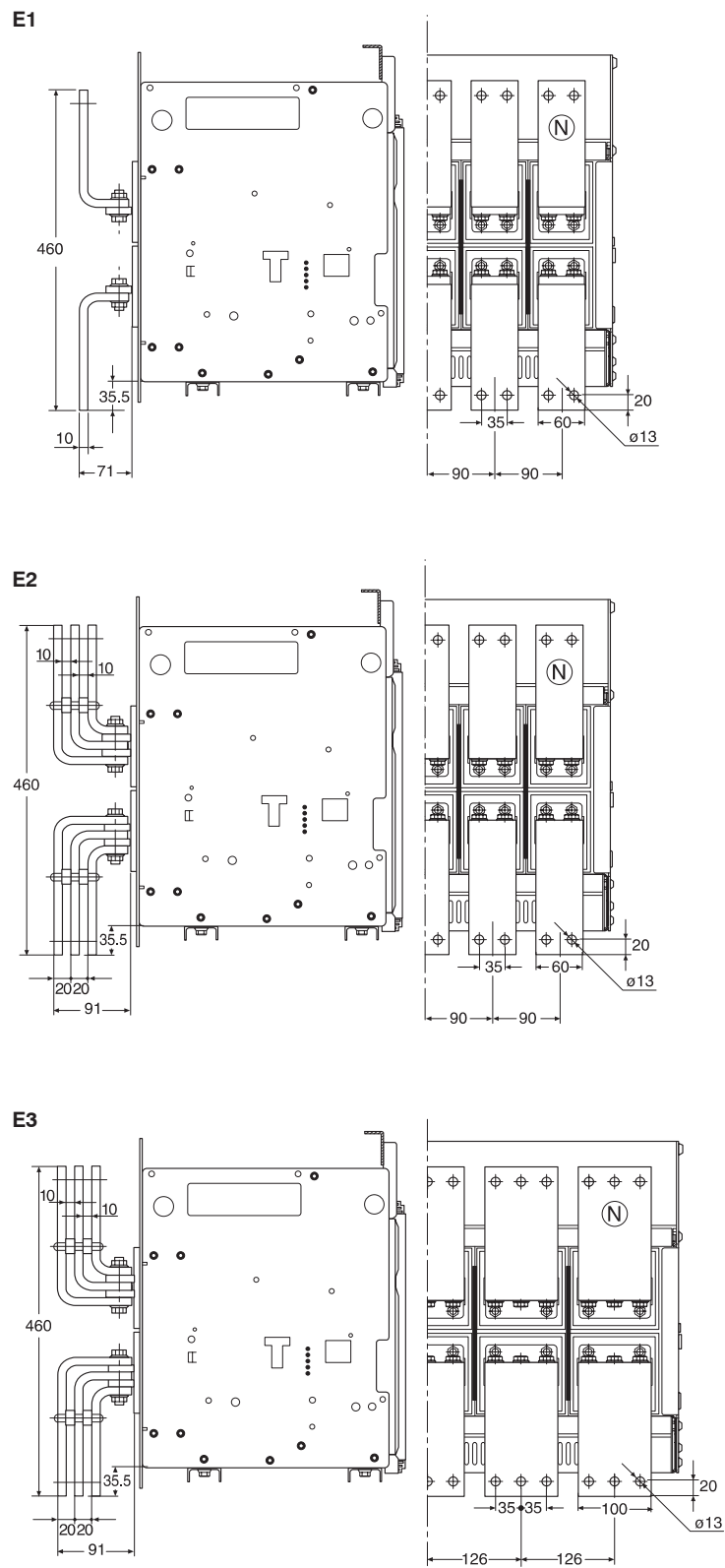

Fig. 43

Mod.	L2234		Apparecchio	Emax	Scala
			N° Doc.	1SDH000460R002	N° Pag. 141/155

Withdrawable circuit-breaker

Version with flat terminals

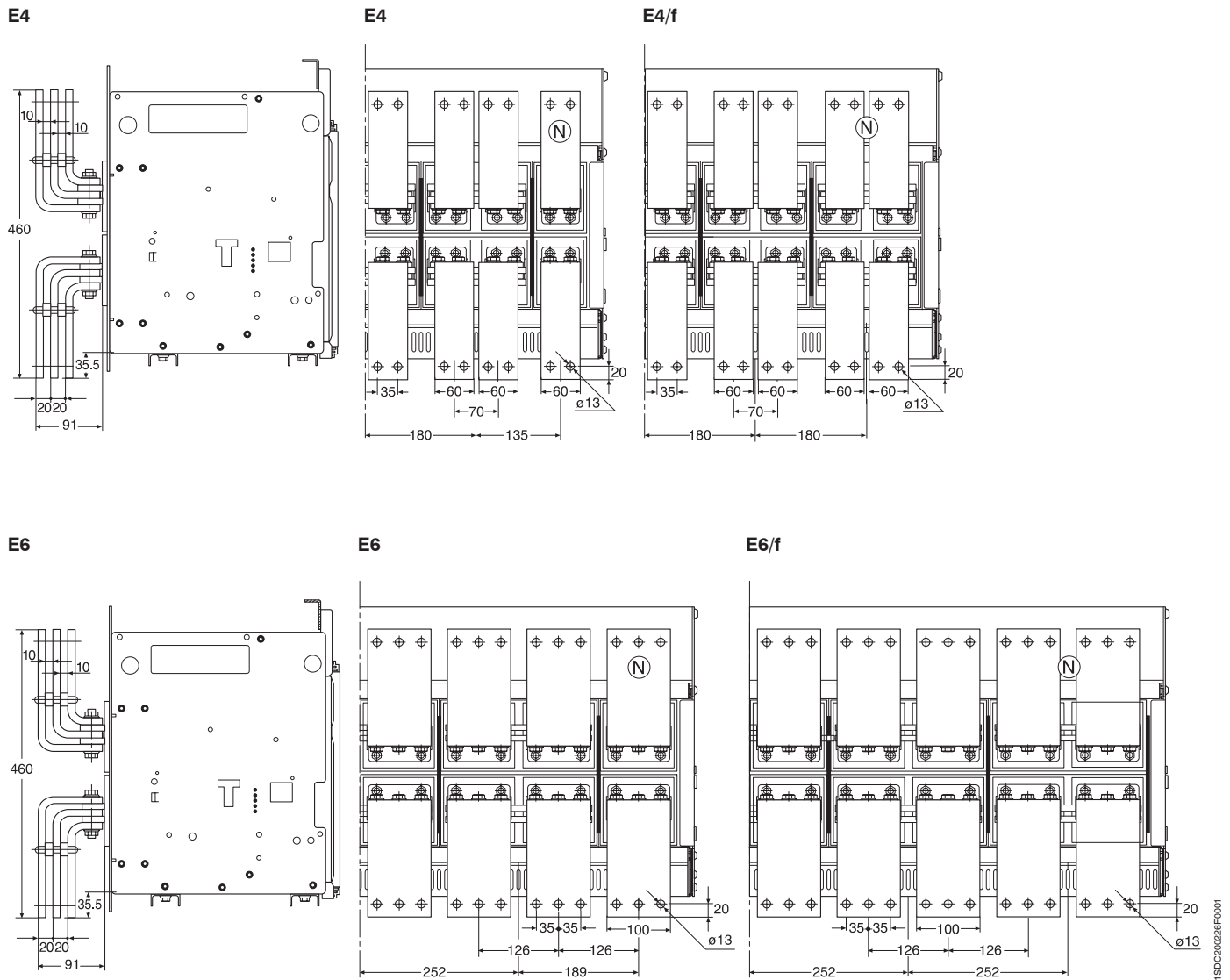

Fig. 44

Mod.	L2234		Apparecchio	Emax	Scala
			N° Doc.	1SDH000460R0002	N° Pag. 142/155

Withdrawable circuit-breaker

Version with flat terminals

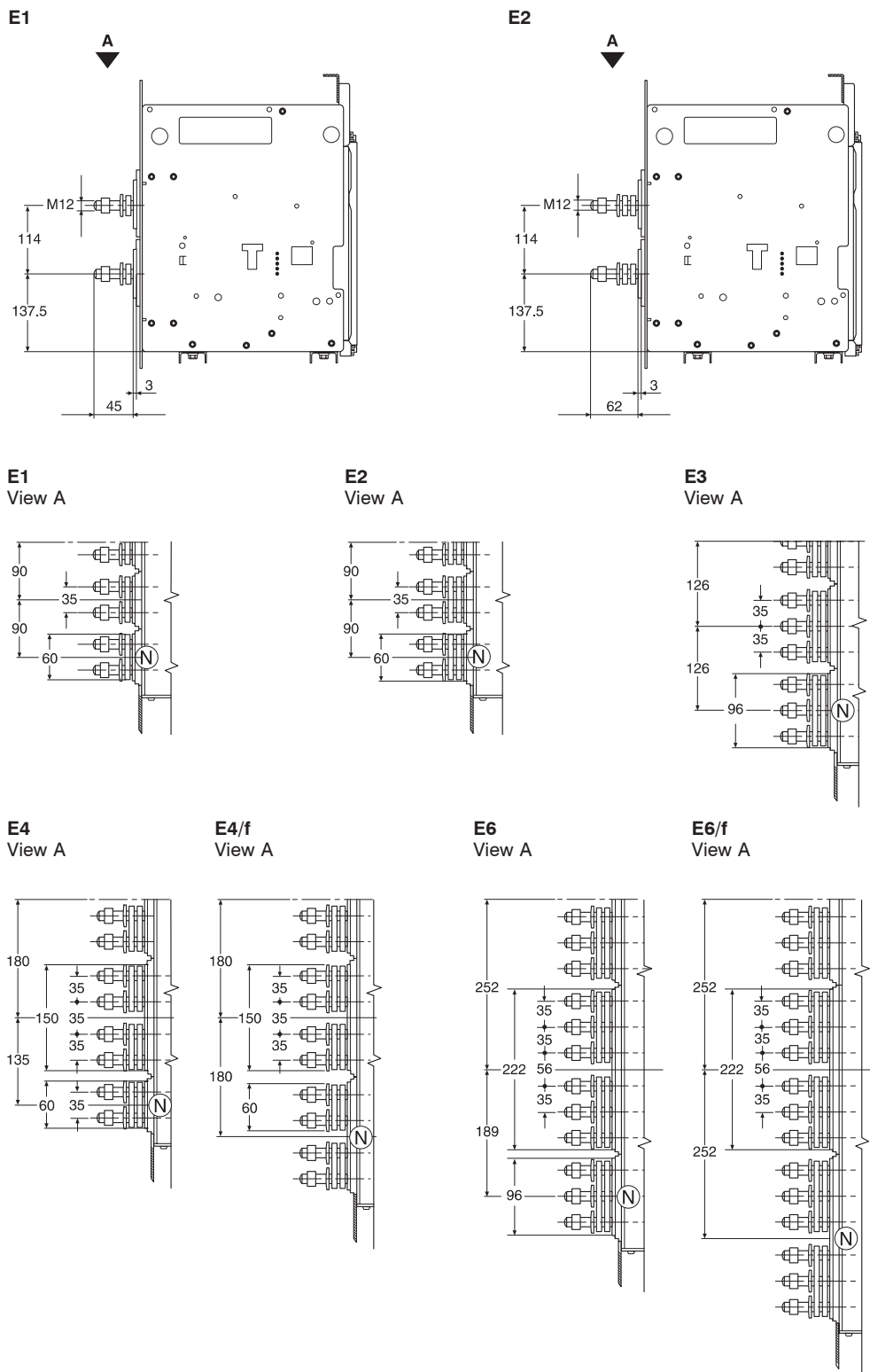
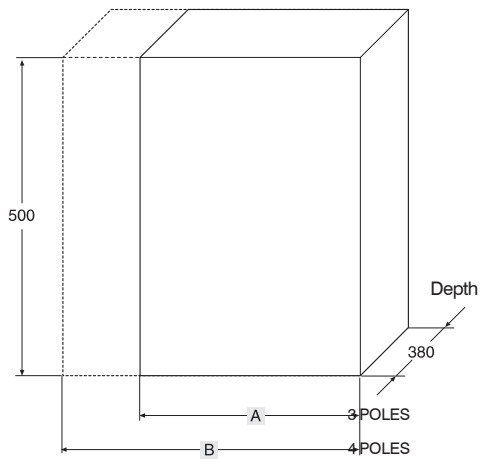

Fig. 45

Mod.	L2234		Apparecchio	Emax	Scala
			N° Doc.	1SDH000460R002	N° Pag. 143/155

Compartment dimensions



Compartment door drilling

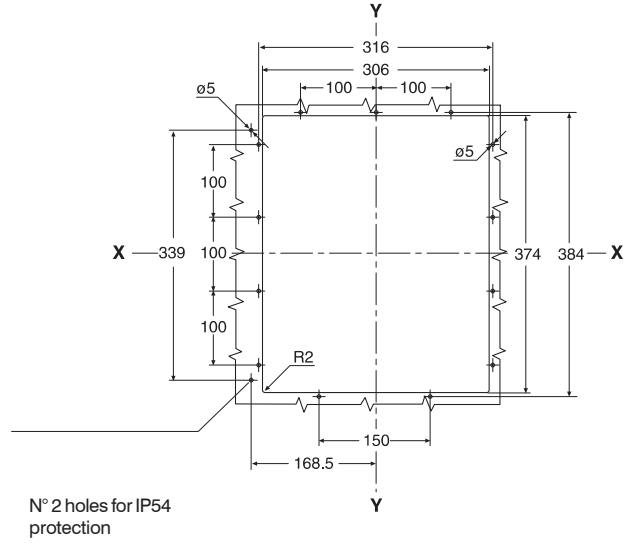

Holes for passing through flexible cables for mechanical interlocks

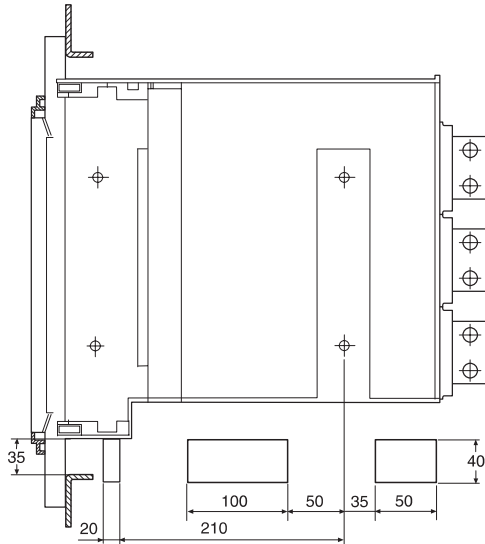

Tightening torque of the fixing screws: 20 Nm
Tightening torque of the main terminals: 70 Nm
Tightening torque of the earthing screw: 70 Nm

	High resistance M12 screw Quantity per terminal	
E1-E2	2	2
	PHASE	NEUTRAL
E3	3	3
E4-E4/f	4	2-4
E6-E6/f	6	3-6

	A	B
E1	400	490
E2	400	490
E3	500	630
E4	700	790
E4/f	-	880
E6	1000	1130
E6/f	-	1260

Fig. 46

Mod.	L2234		Apparecchio	Emax	Scala
			N° Doc.	1SDH000460R0002	N° Pag. 144/155

Compartment door mechanical lock

Door drilling

Minimum distance between the circuit-breaker and the switchgear wall

Fixed version

Withdrawable version

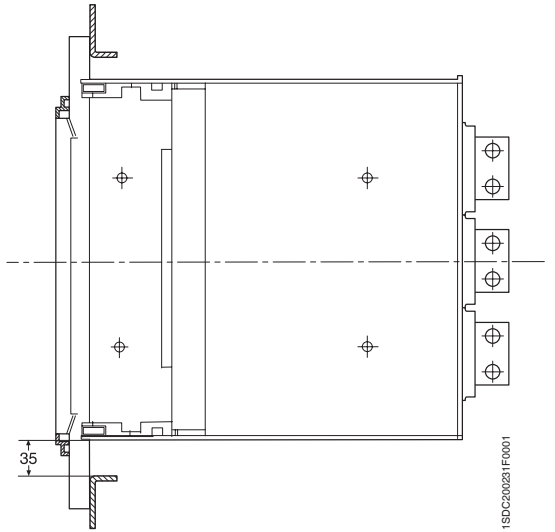
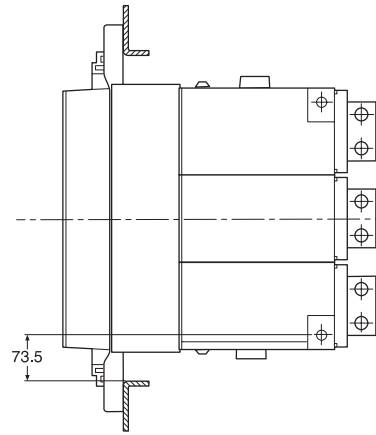
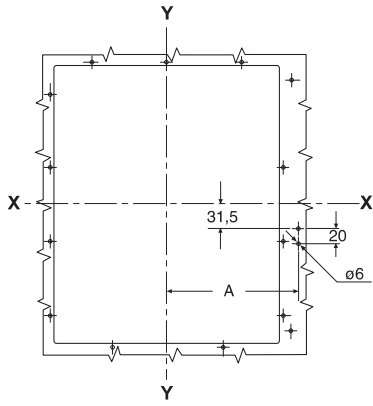

1SDC200231 F0001

	A	
	3 POLES	4 POLES
E1	180	180
E2	180	180
E3	234	234
E4	270	360
E4/f	-	360
E6	360	486
E6/f	-	486

Fig. 47

Mod.	L2234		Apparecchio	Emax	Scala
			N° Doc.	1SDH000460R002	N° Pag. 145/155

18. Circuit diagrams

Warning

Before installing the circuit-breaker, carefully read notes F and O on the circuit diagrams

Operating status shown

The circuit diagram is for the following conditions:

- withdrawable circuit-breaker, open and racked-in
- circuits de-energised
- tripped releases
- motor operating mechanism with springs discharged

Versions

The diagram shows a circuit-breaker in withdrawable version; it can be applied to a fixed version circuit breaker as well

Fixed version

The control circuits are fitted between terminals XV (connector X is not supplied)

With this version, the applications indicated in figures 31 and 32 cannot be provided.

Withdrawable version

The control circuits are fitted between the poles of connector X (terminal box XV is not supplied).

Version without overcurrent release

With this version, the applications indicated in figures 13, 14, 41, 42, 43, 44, 45, 46, 47, 48, 62.

Version with PR121/P electronic release

With this version, the applications indicated in figures 42, 43, 44, 45, 46, 47, 48.

Version with PR122/P electronic release

With this version, the applications indicated in figure 41 cannot be provided.

Version with PR123/P electronic release

With this version, the applications indicated in figure 41 cannot be provided

Caption

□	= Circuit diagram figure number
*	= See note indicated by the letter
A1	= Circuit breaker accessories
A3	= Accessories applied to the fixed part of the circuit breaker (for withdrawable version only)
A4	= Example switchgear and connections for control and signalling, outside the circuit breaker
A13	= PR021/K signalling unit (outside the circuit breaker)
AY	= SACE SOR TEST UNIT Test/monitoring Unit (see note R)
D	= Electronic time-delay device of the undervoltage release, outside the circuit breaker
F1	= Delayed-trip fuse
K51	= PR121/P, PR122/P, PR123/P electronic overcurrent release with the following protection functions: <ul style="list-style-type: none"> - L overload protection with inverse long time-delay trip-setting I1 - S short-circuit protection with inverse or definitive short time-delay trip-setting I2 - I short-circuit protection with instantaneous time-delay trip-setting I3 - G earth fault protection with inverse short time-delay trip-setting I4
K51/1...8	= Contacts for the PR021/K signalling unit
K51/GZin	= (DBin) Zone selectivity: for protection G (only with Vaux and PR122/P or PR123/P release) or "reverse" direction input for protection D (only with Vaux and PR123/P release)
K51/GZout	= (DBout) Zone selectivity: for protection G (only with Vaux and PR122/P or PR123/P release) or "reverse" direction output for protection D (only with Vaux and PR123/P release)
K51/IN1	= Digital programmable input (available only with Vaux and release PR122/P or PR123/P with indicator module PR120/K)
K51/P1...P4	= Programmable electrical signalling (available only with Vaux and release PR122/P or PR123/P with indicator module PR120/K)
K51/SZin	= (DFin) Zone selectivity: input for protection S or "direct" input for protection D (only with Vaux and PR122/P or PR123/P release)
K51/SZout	= (DFout) Zone selectivity: output for protection S or "direct" output for protection D (only with Vaux and PR122/P or PR123/P release)
K51/YC	= Closing control from PR122/P or PR123/P microprocessor-based release with communication module PR120/D-M
K51/YO	= Opening control from PR122/P or PR123/P microprocessor-based release with communication module PR120/D-M
M	= Motor for charging the closing springs
Q	= Circuit breaker
Q/1...27	= Circuit breaker auxiliary contacts
S33M/1...3	= Limit contacts for spring-charging motor
S43	= Switch for setting remote/local control
S51	= Contact for electrical signalling of circuit breaker open due to tripping of the overcurrent release. The circuit breaker may be closed only after pressing the reset pushbutton, or after energizing the coil for electrical reset (if available).
S75E/1.4	= Contacts for electrical signalling of circuit breaker in racked-out position (only with withdrawable circuit-breakers).
S75I/1..5	= Contacts for electrical signalling of circuit breaker in racked-in position (only with withdrawable circuit-breakers)
S75T/1..4	= Contacts for electrical signalling of circuit breaker in test isolated position (only with withdrawable circuit-breakers)
SC	= Pushbutton or contact for closing the circuit breaker
SO	= Pushbutton or contact for opening the circuit breaker
SO1	= Pushbutton or contact for opening the circuit breaker with delayed trip
SO2	= Pushbutton or contact for opening the circuit breaker with instantaneous trip
SR	= Pushbutton or contact for electrical circuit breaker reset
TI/L1	= Current transformer located on phase L1
TI/L2	= Current transformer located on phase L2
TI/L3	= Current transformer located on phase L3

Model	L2234			Apparatus	Emax	Scale
				Doc. N°	1SDH000460R002	Page N° 146/155

Vaux	= Auxiliary power supply voltage (see note F)
UI/L1	= Current sensor (Rogowski coil) located on phase L1
UI/L2	= Current sensor (Rogowski coil) located on phase L2
UI/L3	= Current sensor (Rogowski coil) located on phase L3
UI/N	= Current sensor (Rogowski coil) located on neutral
UI/0	= Current sensor (Rogowski coil) located on the conductor connecting to earth the star point of the MV/LV transformer (see note G)
W1	= Serial interface with control system (external bus): EIA RS485 interface (see note E)
W2	= Serial interface with the accessories of PR121/P, PR122/P and PR123/P releases (internal bus)
X	= Delivery connector for auxiliary circuits of withdrawable version circuit-breaker
X1...X7	= Connectors for the accessories of the circuit breaker
XF	= Delivery terminal box for the position contacts of the withdrawable circuit-breaker (located on the fixed part of the circuit breaker)
KK1	= Connector for power circuits of PR121/P, PR122/P, and PR123/P releases
KK2 - KK3	= Connectors for auxiliary circuits of PR121/P, PR122/P and PR123/P releases
XO	= Connector for YO1 release
XV	= Delivery terminal box for the auxiliary circuits of the fixed circuit breaker
YC	= Shunt closing release
YO	= Shunt opening release
YO1	= Overcurrent shunt opening release (trip coil)
YO2	= Second shunt opening release (see note Q)
YR	= Coil to electrically reset the circuit breaker
YU	= Undervoltage release (see notes B and Q)

Description of figures

- Fig. 1 = Motor circuit to charge the closing springs.
 Fig. 2 = Circuit of shunt closing release.
 Fig. 4 = Shunt opening release.
 Fig. 6 = Instantaneous undervoltage release (see notes B and Q).
 Fig. 7 = Undervoltage release with electronic time-delay device, outside the circuit-breaker (see notes B and Q)
 Fig. 8 = Second shunt opening release (see note Q).
 Fig.11 = Contact for electrical signalling of springs charged.
 Fig.12 = Contact for electrical signalling of undervoltage release energized (see notes B and S).
 Fig.13 = Contact for electrical signalling of circuit breaker open due to tripping of the overcurrent release. The circuit-breaker may be closed only after pressing the reset pushbutton.
 Fig.14 = Contact for electrical signalling of circuit breaker open due to tripping of the overcurrent release and electrical reset coil. The circuit-breaker may be closed only after pressing the reset pushbutton or energizing the coil.
 Fig.21 = First set of circuit-breaker auxiliary contacts.
 Fig.22 = Second set of circuit-breaker auxiliary contacts (not available for PR122/P and PR123/P releases)(see note V)
 Fig.23 = Third set of supplementary auxiliary contacts outside the circuit breaker.
 Fig.31 = First set of contacts for electrical signalling of circuit breaker in racked-in, test isolated, racked-out position.
 Fig.32 = Second set of contacts for electrical signalling of circuit breaker in racked-in, test isolated, racked-out position.
 Fig.41 = Auxiliary circuits of PR121/P release (see note F).
 Fig.42 = Auxiliary circuits of PR122/P and PR123/P releases (see notes F, M and V).
 Fig.43 = Circuits of the measuring module PR120/V of the releases PR122/P and PR123/P internally connected to the three-pole and four-pole circuit breaker (optional for the release PR122/P) (see note U).
 Fig.44 = Circuits of the measuring module PR120/V of the PR122/P and PR123/P releases externally connected to the circuit-breaker (optional for the release PR122/P) (see note U).
 Fig.45 = Circuits of the communication module PR120/D-M of the PR122/P and PR123/P releases (optional) (see note E).
 Fig.46 = Circuits of the indicator module PR120/K of the PR122/P and PR123/P releases - connection 1 (optional) (see note V).
 Fig.47 = Circuits of the indicator module PR120/K of the PR122/P and PR123/P releases - connection 2 (optional) (see note V).
 Fig.48 = Circuits of the measuring module PR120/V of the releases PR122/P and PR123/P connected inside the three-pole circuit breaker with outside neutral conductor (optional for the release PR122/P)(see note U).
 Fig.62 = Circuits of the signalling unit PR021/K (outside the circuit breaker).

Incompatibilities

The circuits indicated in the following figures cannot be supplied simultaneously on the same circuit breaker:

- 6 - 7 - 8
 13 - 14
 22 - 46 - 47
 43 - 44 - 48

Notes

- A) The circuit breaker is only fitted with the accessories specified in the ABB SACE order acknowledgement. Consult this catalogue for information on how to make out an order.
 B) The undervoltage release is supplied for operation using a power supply branched on the supply side of the circuit breaker or from an independent source. The circuit breaker can only close when the release is energized (there is a mechanical lock on closing).
 If the same power supply is used for the closing and undervoltage releases and the circuit breaker is required to close automatically when the auxiliary power supply comes back on, a 30 ms delay must be introduced between the undervoltage release accept signal and the energizing of the closing release. This may be achieved using an external circuit comprising a permanent make contact, the contact shown in fig. 12 and a time-delay relay.
 E) For the EIA RS485 serial interface connection see document RH0298 regarding MODBUS communication.
 F) The auxiliary voltage Vaux allows actuation of all operations of the PR121/P, PR122/P and PR123/P releases.
 Having requested a Vaux insulated from earth, one must use "galvanically separated converters" in compliance with IEC 60950 (UL 1950) or equivalent standards that ensure a common mode current or leakage current (see IEC 478/1, CEI 22/3) not greater than 3.5 mA, IEC 60364-41 and CEI 64-8.
 G) Earth fault protection is available with the PR122/P and PR123/P releases by means of a current sensor located on the conductor connecting

Model	L2234		Apparatus	Emax	Scale
			Doc. N°	1SDH000460R002	Page N° 147/155







to earth the star center of the MV/LV transformer.

The connections between terminals 1 and 2 (or 3) of current transformer UI/O and poles T7 and T8 of the X (or XV) connector must be made with a two-pole shielded and stranded cable (type BELDEN 3105A/3105B) no more than 15 m long. The shield must be earthed on the circuit breaker side and current sensor side.

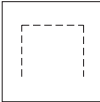
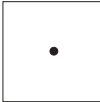
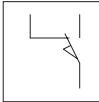
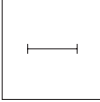
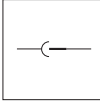
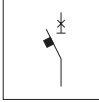
- N) With releases PR122/P and PR123/P, the connections to the zone selectivity inputs and outputs must be made with a two-pole shielded and stranded cable (type BELDEN 3105A/3105B), no more than 300 m long. The shield must be earthed on the selectivity input side.
- O) Systems with a rated voltage greater than 690V require the use of an insulation voltage transformer to connect to the busbars (connect according to the diagrams on the sheet provided with the kit 1SDH000460R0508).
- P) With releases PR122/P and PR123/P with communication module PR120/D-M, the coils YO and YC are controlled directly from contacts K51/YO and K51/YC with maximum voltages of 110-120 V DC and 240-250 V AC.
- Q) The second opening release may be installed as an alternative to the undervoltage release.
- R) The SACE SOR TEST UNIT + opening release (YO) is guaranteed to operate starting at 75% of the Vaux of the opening release itself. While the YO power supply contact is closing (short-circuit on terminals 4 and 5), the SACE SOR TEST UNIT is unable to detect the opening coil status.
Consequently:
 - For continuously powered opening coil, the TEST FAILED and ALARM signals will be activated
 - If the coil opening command is of the pulsing type, the TEST FAILED signal may appear at the same time. In this case, the TEST FAILED signal is actually an alarm signal only if it remains lit for more than 20s.
- S) Also available in the version with normally-closed contact
- U) The measuring module PR120/V is always supplied with relay PR123/P.
- V) If fig. 22 is present (second set of auxiliary contacts) simultaneously as realy PR122/P (or PR123/P), the contacts for the zone selectivity in fig. 42 (K51/Zin, K51/Zout, K51/Gzin and K51/Gzout) are not wired. In addition, the indicator module PR120/K in figures 46 and 47 cannot be supplied.

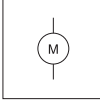
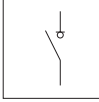
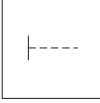
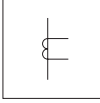
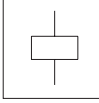
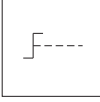
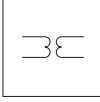
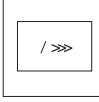
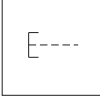
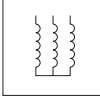
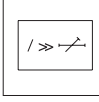
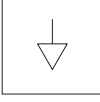
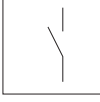
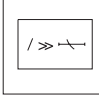
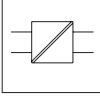
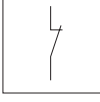
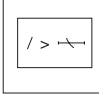
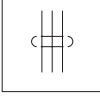
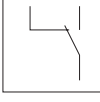
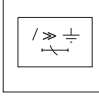
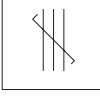
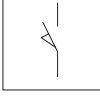
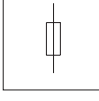
Model	L2234			Apparatus	Emax	Scale
				Doc. N°	1SDH000460R002	Page N° 148/155

Circuit diagram symbols (IEC 60617 and CEI 3-14 ... 3-26 Standards)

	Shield (may be drawn in any shape)		Terminal		Position switch (limit switch) change-over break before make contact
	Delay		Plug and socket (male and female)		Circuit-breaker-disconnector with automatic release
	Mechanical or electrical connection		Motor (general symbol)		Switch-disconnector (on-load isolating switch)
	Manually operated control (general case)		Current transformer		Operating device (general symbol)
	Operated by turning		Voltage transformer		Instantaneous overcurrent or rate-of-rise relay
	Operated by pushing		Winding of three-phase transformer, connection star		Overcurrent relay with adjustable short time-lag characteristic
	Equipotentiality		Make contact		Overcurrent relay with inverse short time-lag characteristic
	Converter with galvanic separator		Break contact		Overcurrent relay with inverse long time-lag characteristic
	Conductors in a screened cable (i.e., 3 conductors shown)		Change-over break before make contact		Earth fault overcurrent relay with inverse short time-lag characteristic
	Twisted conductors (i.e., 3 conductors shown)		Position switch (limit switch), make contact		Fuse (general symbol)
	Connection of conductors		Position switch (limit switch), break contact		Current sensing element

Model	L2234		Apparatus	Emax	Scale
			Doc. N°	1SDH000460R002	Page N° 149/155

Circuit diagram - Operating status

Three-pole circuit-breaker with PR121/P, PR122/P or PR123/P electronic release

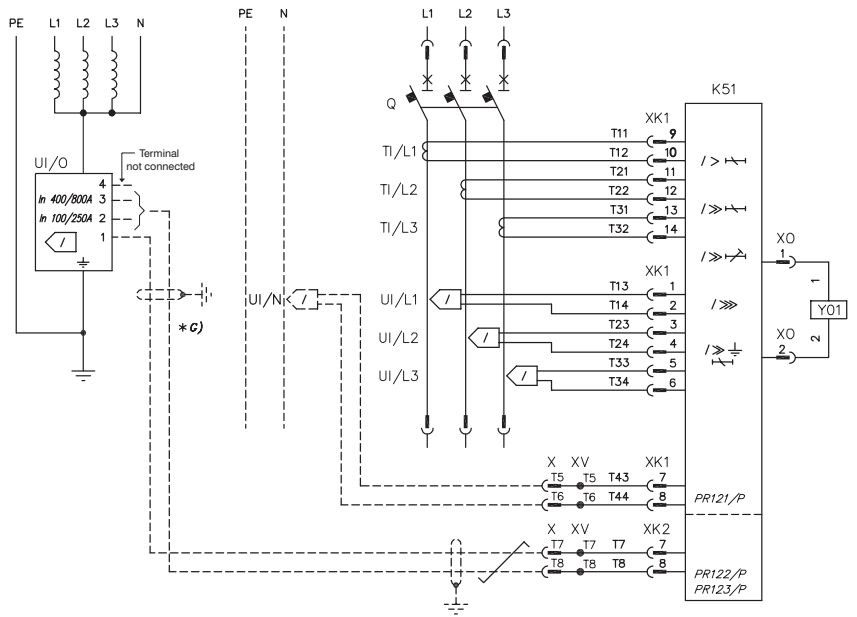

Four-pole switch with PR121/P, PR122/P, PR123/P electronic release

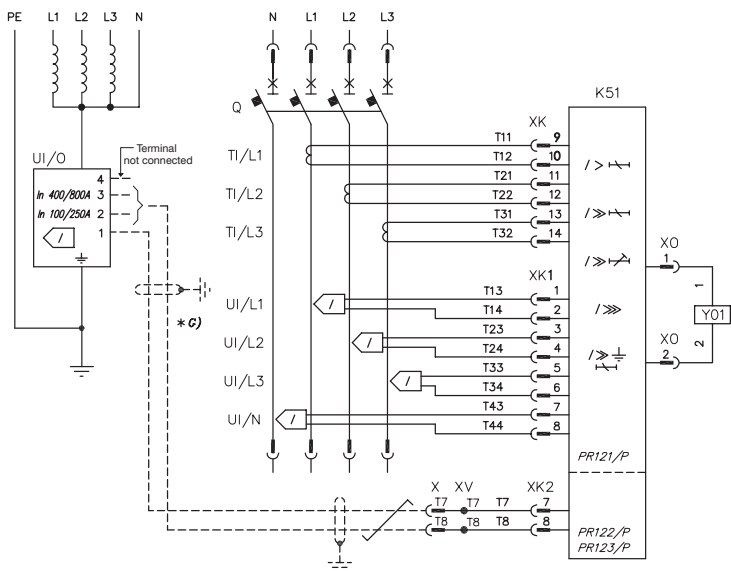

Three-or-four-pole switch-disconnector

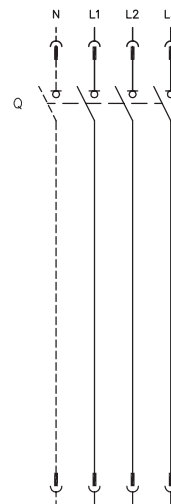

Model	L2234		Apparatus	Emax	Scale
			Doc. N°	1SDH000460R002	Page N° 150/155

Motor operating mechanism, opening, closing and undervoltage releases

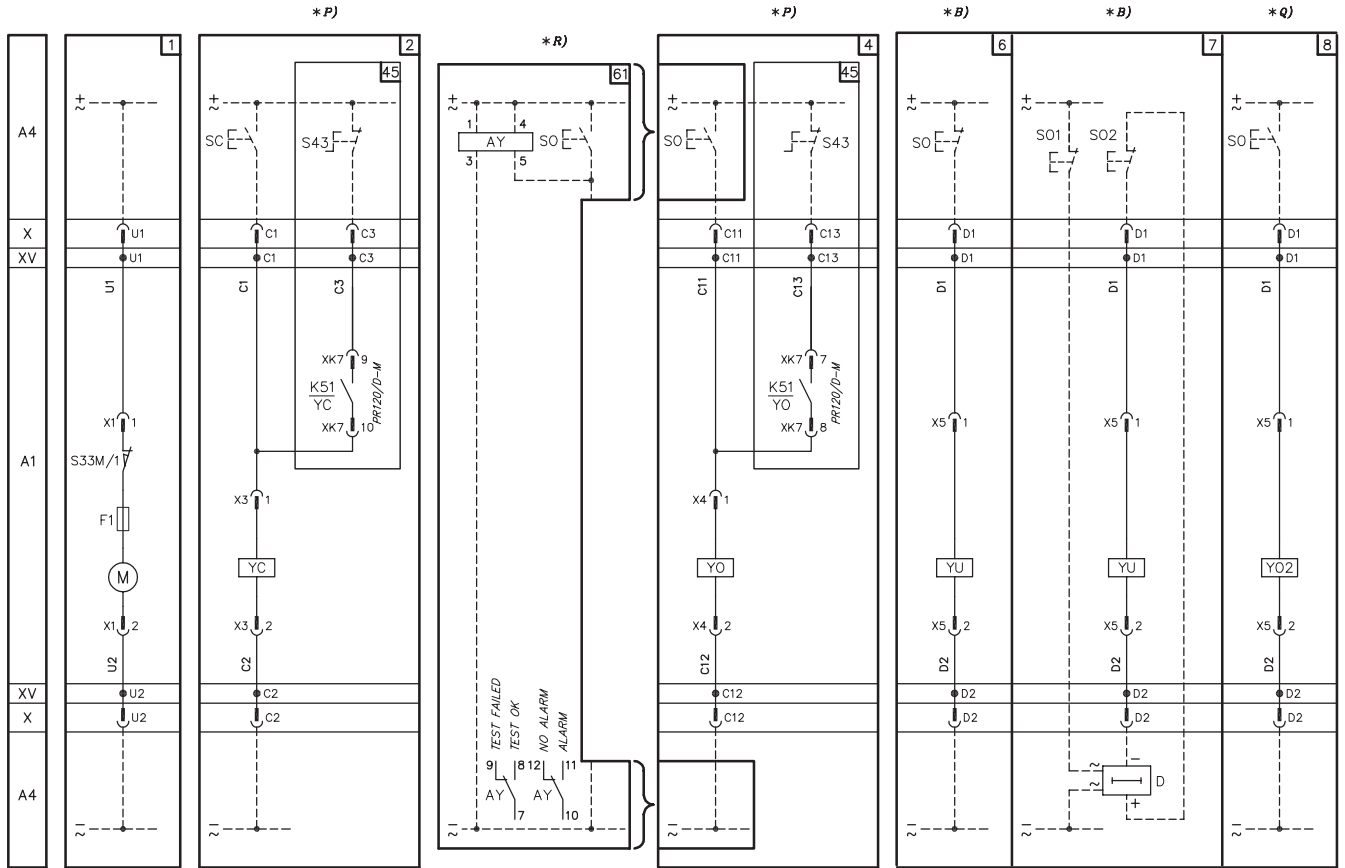

Signalling contacts

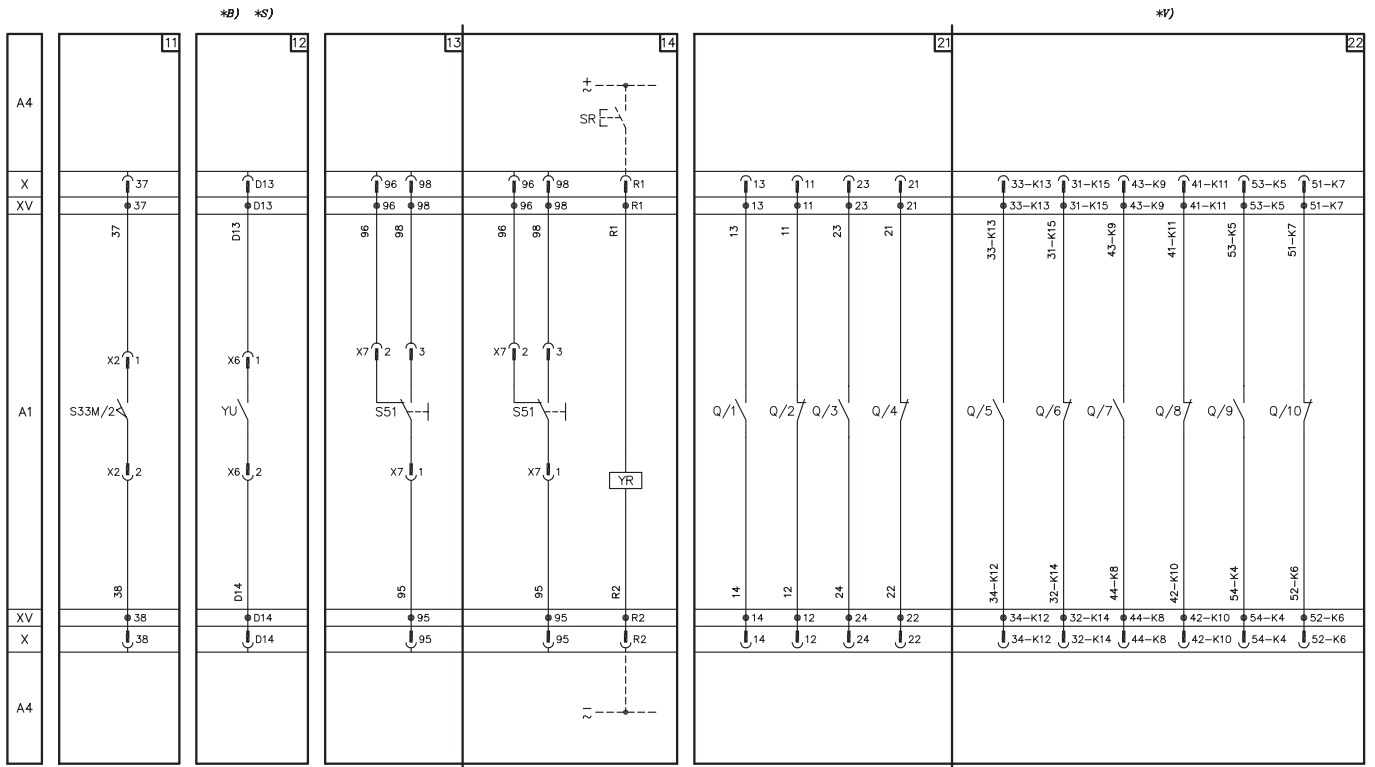

Model	L2234	Apparatus	Emax	Scale
		Doc. N°	1SDH000460R002	Page N° 151/155

Signalling contacts

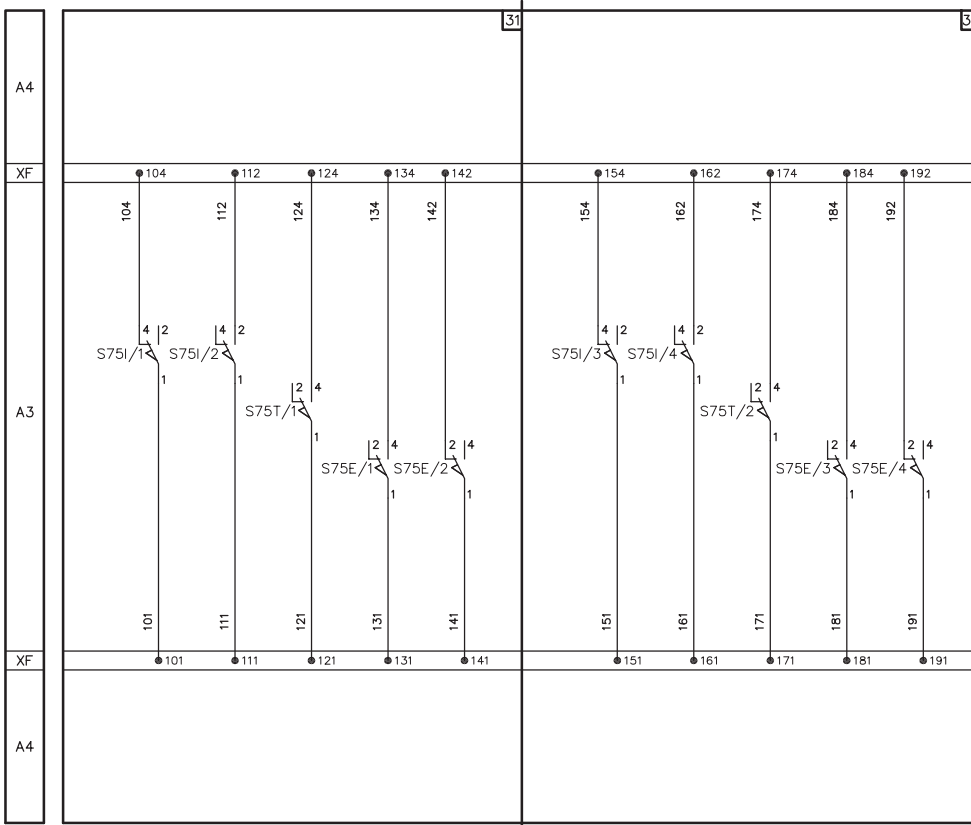
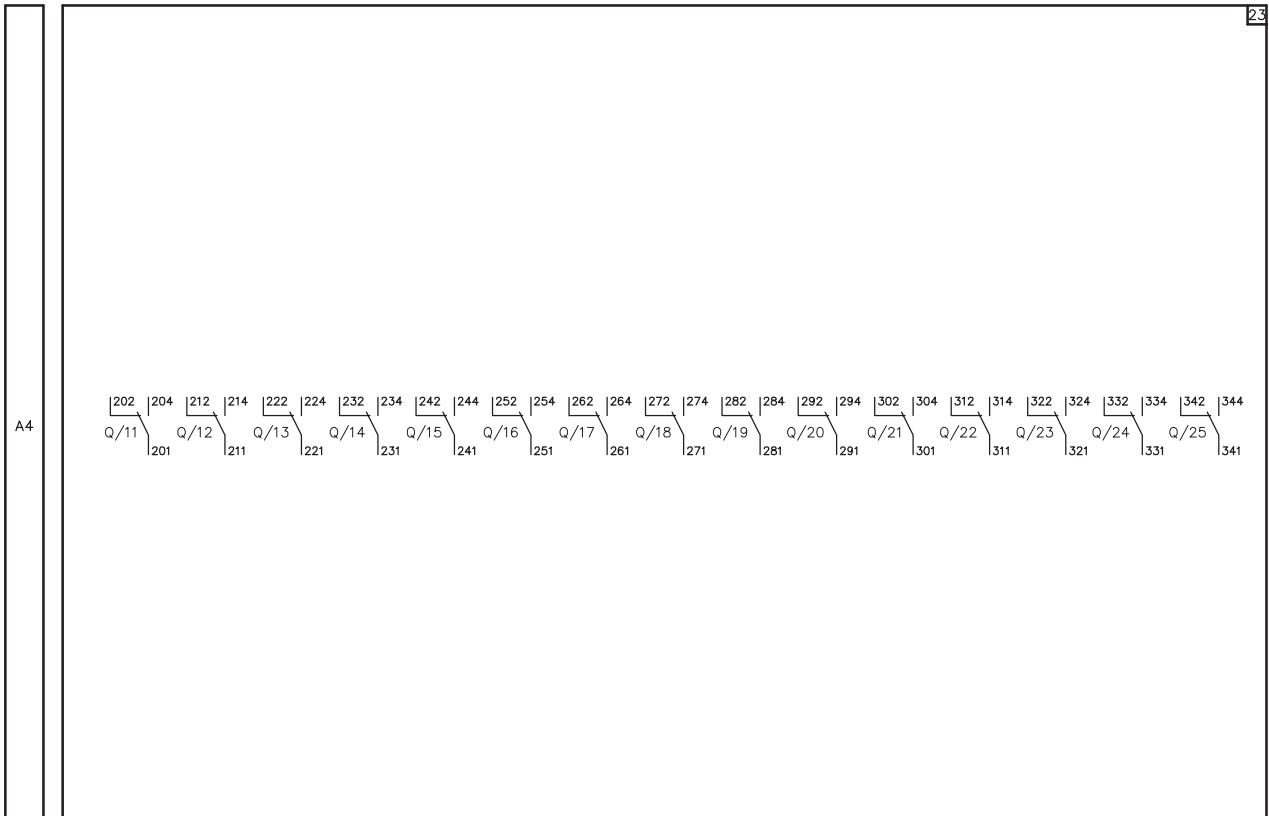

Model	L2234	Apparatus	Emax	Scale
		Doc. N°	1SDH000460R002	Page N° 152/155

Auxiliary circuits of the PR121, PR122 and PR123 releases

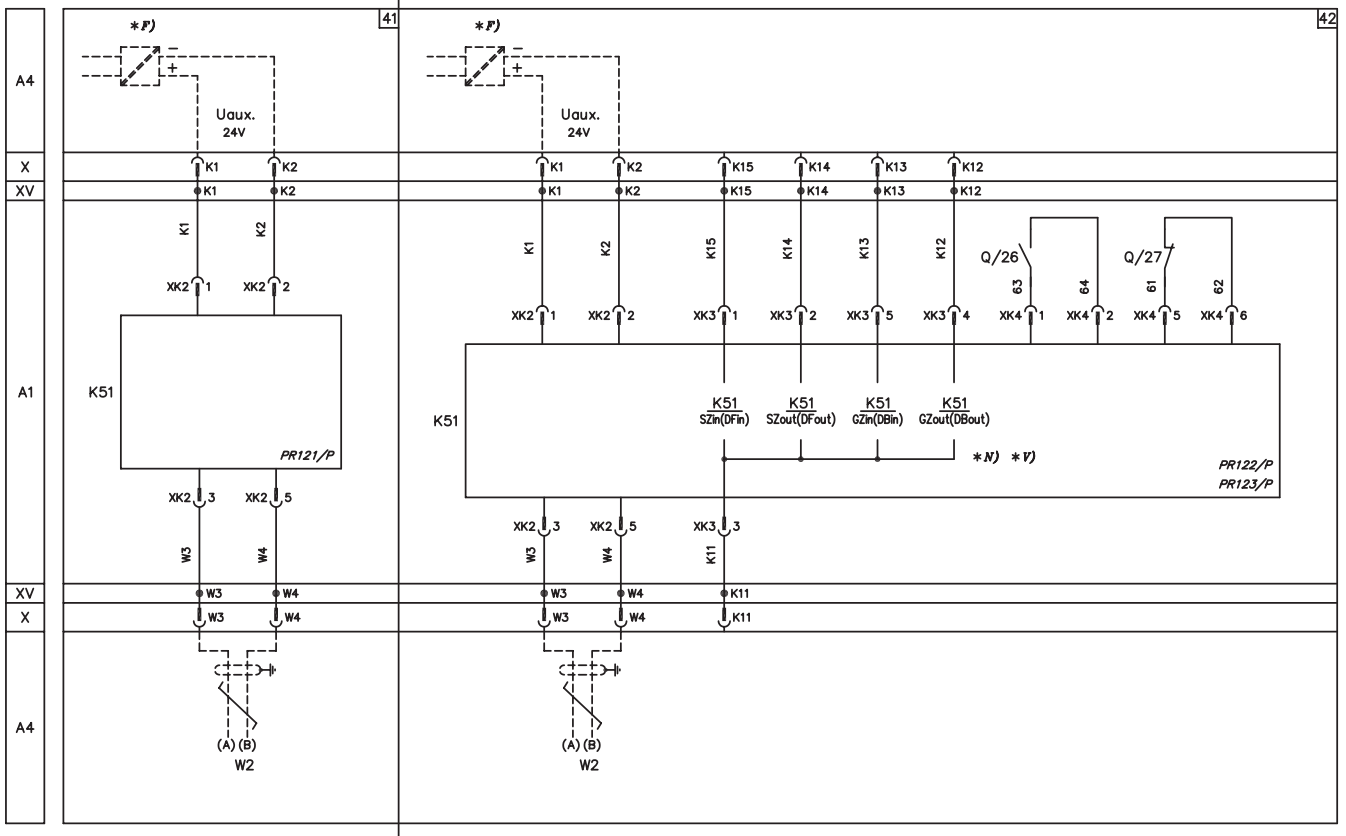

PR120/V measuring module

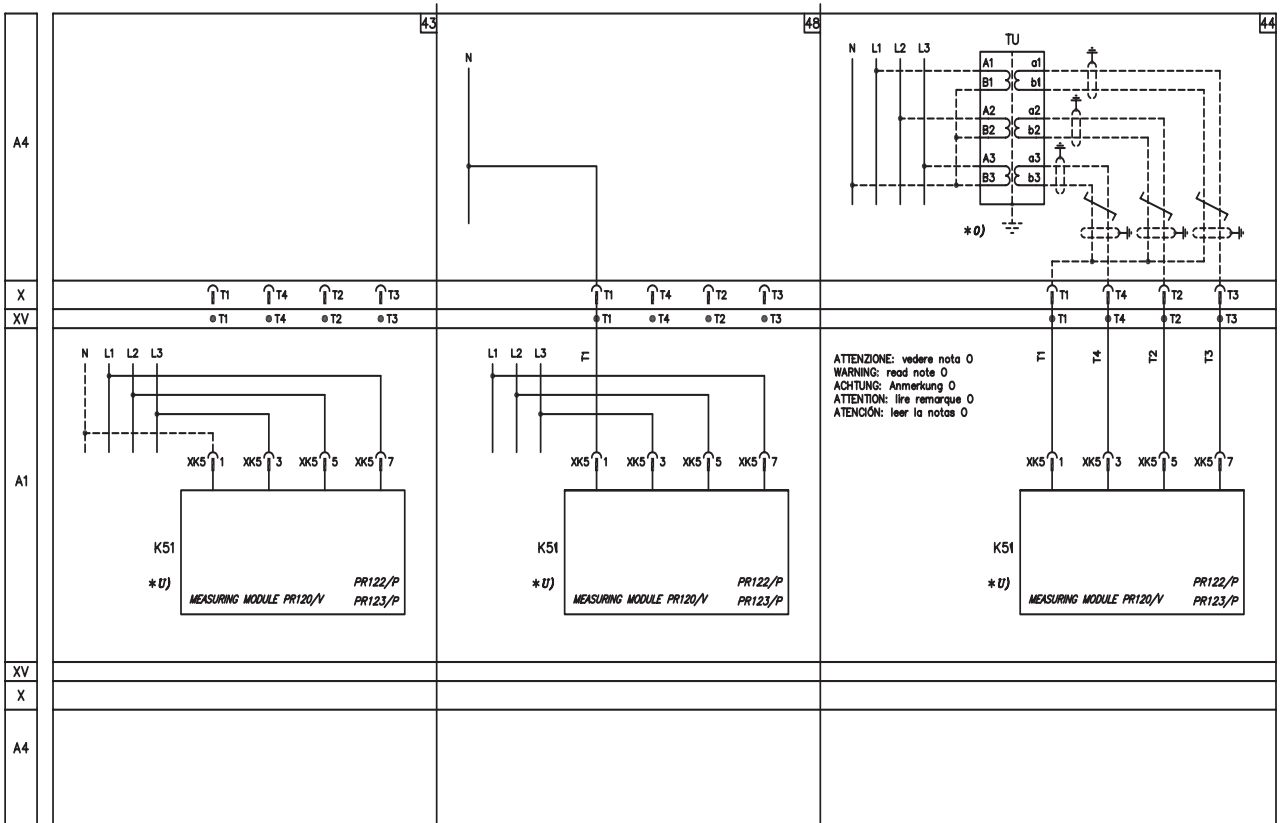

PR120/D-M communication module

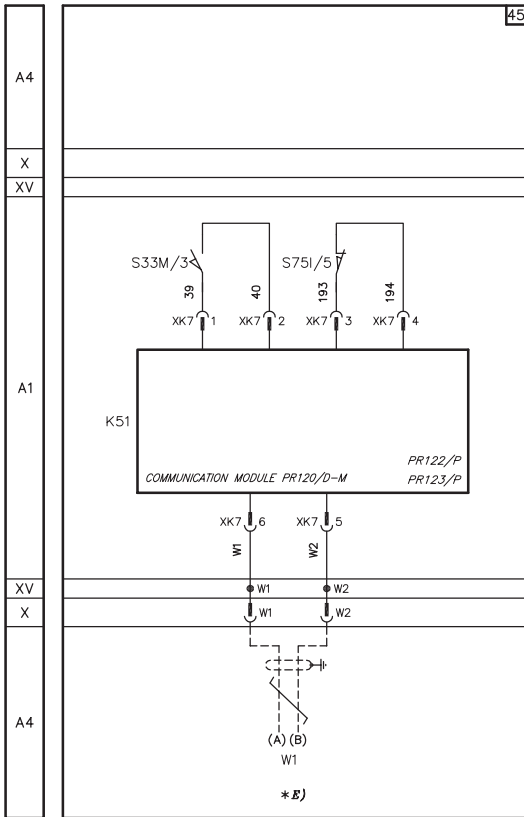

PR120/K signalling module

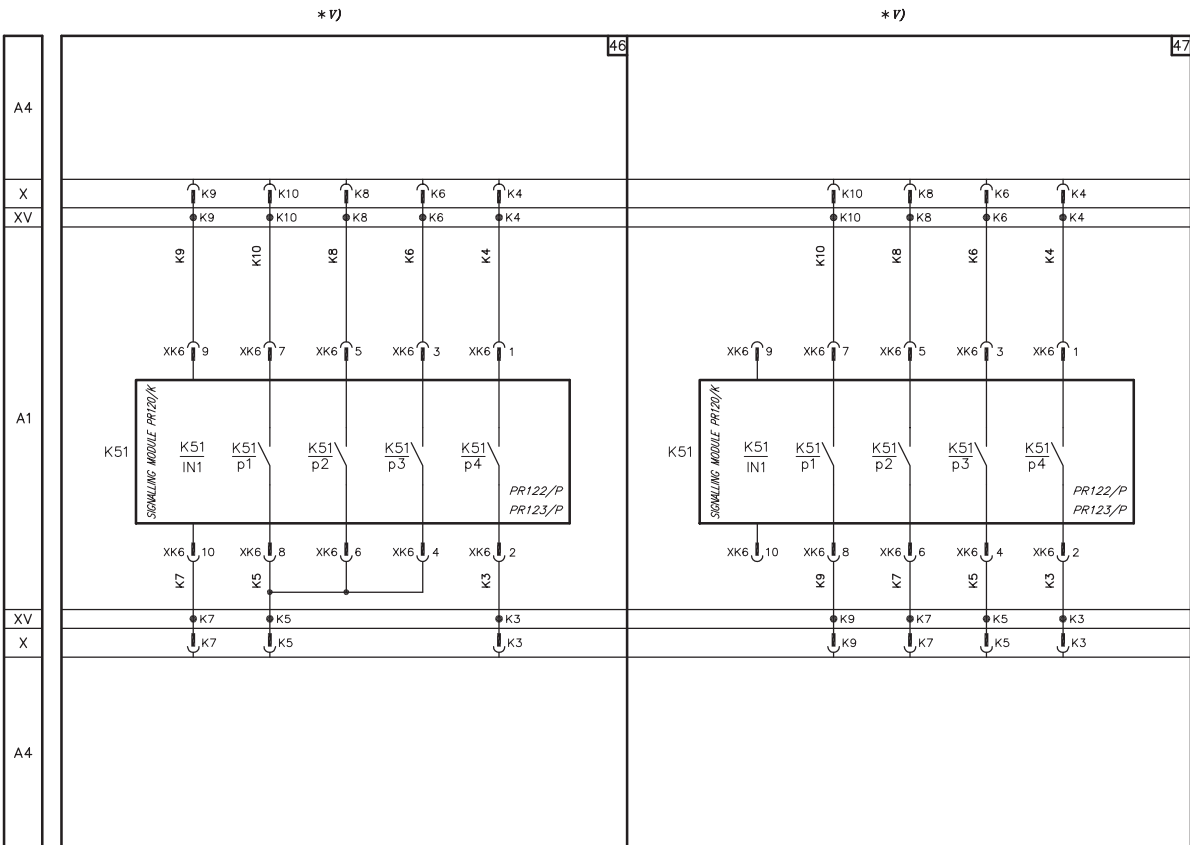

Model	L2234		Apparatus	Emax	Scale
			Doc. N°	1SDH000460R002	Page N° 154/155

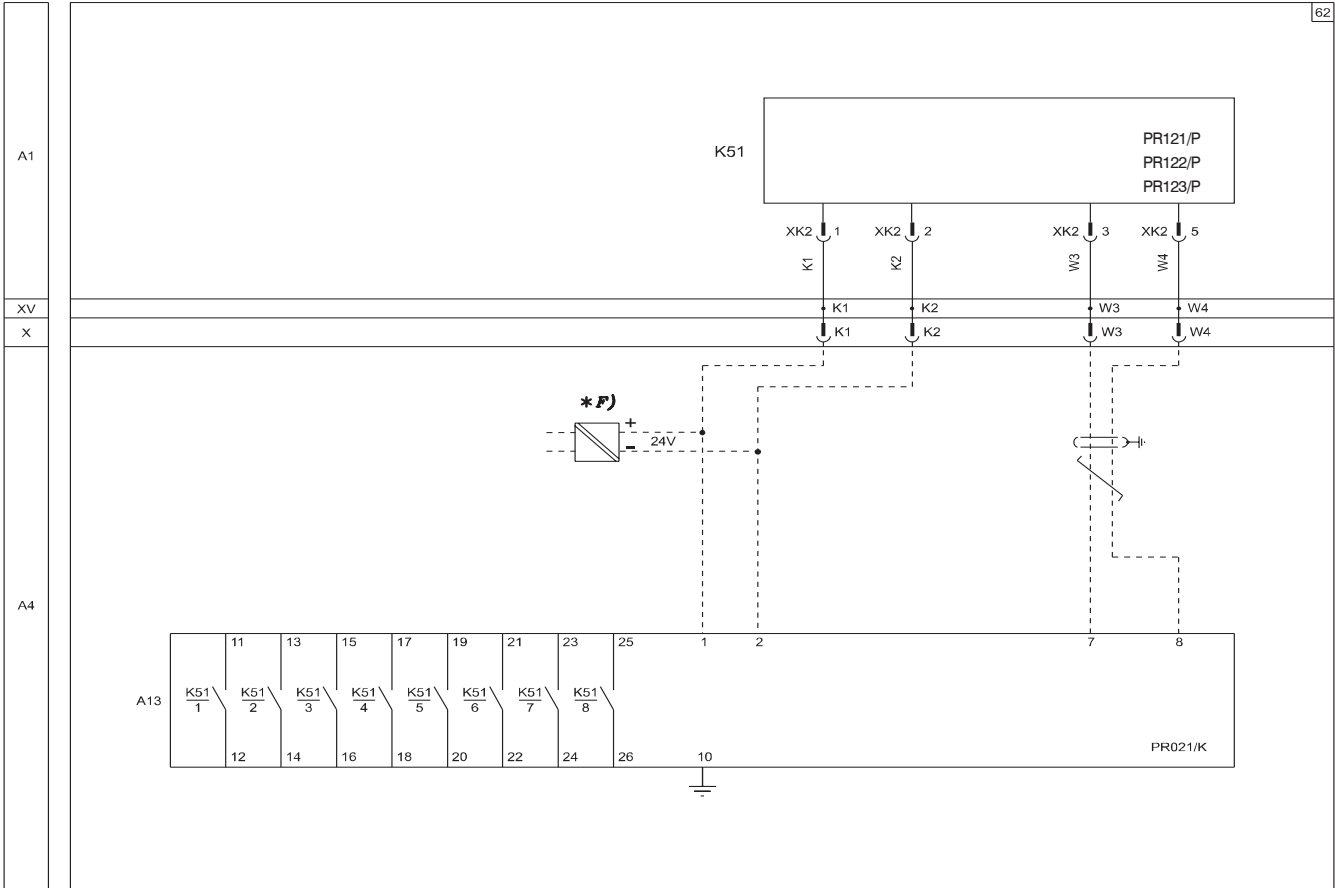

Model	L2234		Apparatus	Emax	Scale
			Doc. N°	1SDH000460R002	Page N° 155/155



ABB SACE S.p.A.
L.V. Breakers
Via Baioni, 35 - 24123 Bergamo - Italy
Tel.: +39 035.395.111 - Telefax: +39 035.395.306-433
<http://www.abb.com>

Due to possible developments of standards as well as of materials, the characteristics and dimensions specified in the present catalogue may only be considered binding after confirmation by ABB SACE.