

**Latest updated
2009-04-21**

Type PSR
Type PSS
Type PST/PSTB

Catalogue 1SFC132004C0201, Edition 4 September 2008



Softstarters

News

Torque control

The latest version of the PST(B) softstarter offers a new functionality called Torque control. With this function enabled the voltage of the motor is regulated so that the torque follows a predefined torque curve during start and stop. Torque control is especially useful in pump applications where a sudden stop can cause water hammering and pressure surges.



Analog output

With the latest version of the PST(B) softstarter it is possible to have analog output signals from the softstarter. These signals can then be used as input to a PLC or an analog meter.

Type PSR Softstarter

The latest addition to the ABB softstarter range is the compact PSR softstarter. This new softstarter has a compact, attractive design and is ideal for installation in places where space is limited and where there is a demand for easy installation.

Complete range

With the new PSR softstarter, ABB offers a complete range of softstarters from 3 to 1810 A. This complete range consists of the three models PSR, PSS and PST(B).

ABB Softstarters – the complete range

Functionality

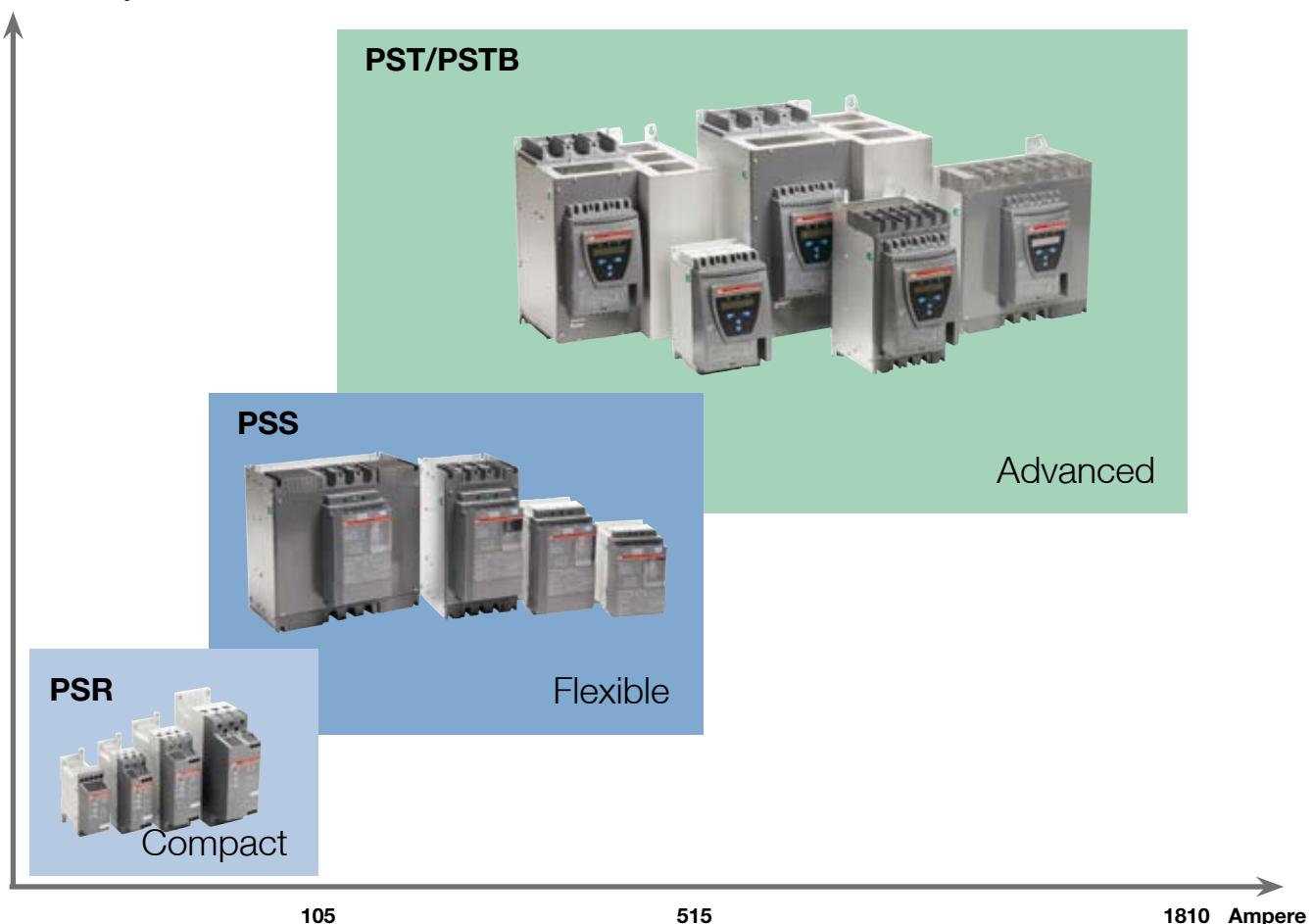

Contents

	Page
General	4
The complete range	5
Softstarters, type PSR	
Overview	6
Description	7
Ordering (incl. accessories).....	8
Technical data, UL ratings	9
Softstarters, type PSS	
Overview	10
Application and Description.....	12
Ordering.....	14
Accessories.....	18
Technical data	19
UL ratings.....	21
Softstarters, type PST	
Overview	22
Application and Description.....	24
Ordering.....	26
Accessories.....	30
FBP Field Bus Plug.....	31
Technical data	37
UL ratings.....	41
Wall mounting instruction	42
Dimensions	43
Circuit diagrams	46
Certifications and approvals	49
Leader in power and automation technologies, Division Automation Products, Low voltage products	51

Some information about the catalogue:

Ordering details:

When placing an order please give either the "**Type**" or the "**Order code**". Please note that for some of the products you need to fill in some additional code letters/code numbers to define the complete Type/Order code.

Packing:

All softstarters and most of the accessories are delivered in an individual packing. Some of the accessories are packed together in batches of "n" pieces (see ordering "**Pack^{ing} pieces**"). For these items, please order the total amount corresponding to a multiple of the number in the packing. Example: If two in the packing, then please order minimum two, four, six etc.

*Note: Each "**Type**" or "**Order code**" always corresponds to only one piece.*

The products described in this catalogue are subject to change (design, dimensions, technical data, etc.) without prior notice.



Softstarters

From the moment the first electrical motors appeared, engineers have been searching a way to avoid electrical and mechanical problems that occur using Direct-on-Line and Star-Delta starters. ABB has been producing softstarters since the beginning of the 1980's. The valuable experience gained since the early 80's has been incorporated into the design of today's product ranges. With the latest series named PST, ABB has taken a significant step further in soft starting technology. Matching modern power electronics with smart circuitry and software, the new PST softstarter offers superior electronic control of the current and voltage during motor start-up, in addition to several new design features.

The solution to both mechanical and electrical problems

AC motors, "the workhorse of the industry", that are used to drive fans, crushers, agitators, pumps, conveyors etc., are unnecessarily causing unwanted load peaks day in and day out in production plants all over the world. These violent starts cause damage in several ways. Among them are:

- Electrical problems due to voltage and current transients arising from Direct-on-Line or Star-Delta starts. Such transients may overload the local supply network and cause unacceptable voltage variations that interfere with other electrical equipment connected to the network.
- Mechanical problems that address the entire drive chain, from motor to driven equipment, to severe stress.
- Operational problems, such as pressure surges in pipelines, damage to products on conveyor belts and uncomfortable escalator rides.

The financial consequences are considerable: every technical problem and every breakdown, costs money – in terms of repairs as well as lost production.

The easy solution to all of these problems is to install an ABB Softstarter type PSR, PSS or PST. With ABB Softstarters, it is possible to start and stop smoothly while keeping mechanical and electrical stresses to a minimum.

Motor voltage

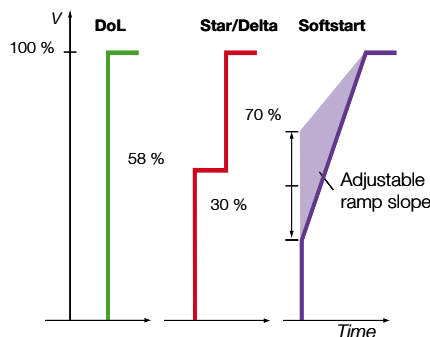

Motor current

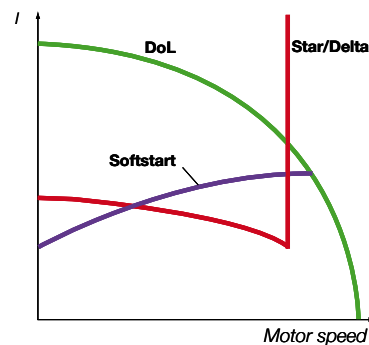

Torque

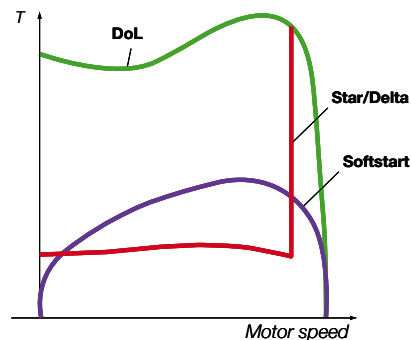

Graphs showing the basic differences between direct-on-line starting (DoL), star-delta starting and soft starting in terms of the motor voltage (V), motor current (I) and motor torque (T).



ABB softstarters – The complete range

ABB offers three different ranges of softstarters to cover every customer need for solutions for small to medium-sized motor applications, from 3 A to 1810 A. The overview table at the bottom of this page shows the main characteristics of the different types. For more specific technical details and ordering data, see the following pages.

Compact Range

Type PSR, covers motor currents from 3 to 105 A. It is the latest addition to the softstarter family and has an attractive, compact design. Further, the system concept includes MMS and the softstarters are available for remote control connection using the FieldBusPlug as an accessory. All sizes include a Run signal relay, while from sizes 25 A the PSR Softstarters are also provided with an output signal for TOR (Top Of Ramp), i.e. full voltage). With standard performance the PSR Softstarters handle ten starts per hour. When an auxiliary cooling fan is added, the starting capacity is increased to 20 starts per hour.

- Current ratings 3.9 – 105 A (1.5 - 55 kW), at 400 V
- Motor voltage 208 – 600 V
- Supply voltage 24 V DC or 100-240 V AC
- Easy to install and adjust
- DIN rail or screw mounting
- Integrated by-pass contacts

With their compact design, the PSR Softstarters are ideal for installation in places where space is limited and where there is a demand for easy installation.

Flexible Range

Type PSS, covers motor currents from 18 to 300 A and offers a flexible solution with easy installation and setup.

- **Flexible:** With two connection possibilities, either in line with the motor or inside the motor delta. It can also be equipped with current limit.
- **Easy to set up:** With just three clearly labeled rotary switches on the front of the unit it is possible to adjust the PSS Softstarter for a wide range of applications.
- **Solid state electrical circuit:** This ensures the highest reliability and reduces maintenance to a minimum, even in applications with frequent starts and stops.

Advanced Range

Type PST(B), covers motor currents from 30 to 1050 A and provides advanced functionality, including integrated protections, programmable signal relays, a flexible communication

system and an LCD display. Sizes PSTB370 to 1050 A include a by-pass contactor.

- **Advanced integrated protections:** For the motor; integrated electronic overload relay, phase monitoring relays, high current and PTC protection. For the Softstarter; advanced thyristor protection.
- **Flexible bus communication system:** By using the ABB FieldBusPlug (FBP), you can decide at any time which bus system to select within the ABB FBP range. The interface between the PST Softstarter and the ABB FBP is always the same, independent of size and delivery date.
- **LCD display:** With 14 languages, a menu system similar to your mobile phone, preprogrammed application settings and automatic status and event logging, it couldn't be easier to set up and operate!
- **Programmable signal relays:** gives you several possibilities for signalling warnings, faults and other events.
- **Torque control:** allows you to start and stop motors with a more linear acceleration than when using voltage ramp.

PSR3 ...105	PSS18/30 ...300/515	PST30 ... PSTB1050	
○	–	•	Field bus communication enabled
–	–	•	Real time clock
–	–	•	Programmable fault supervision functions
–	–	•	Programmable warning functions
–	–	•	PTC input for motor protection
–	–	•	High current protection
–	–	•	Phase imbalance /phase reversal protection
–	–	•	Locked rotor protection
–	–	•	Thyristor overtemperature protection
–	–	•	Motor overload protection
–	–	•	Four button keypad (external keypad available)
–	–	○	External keypad
–	○	•	Current limit control
–	•	•	In Line and Inside Delta connection
•	•	•	LED indications
•	–	• ¹⁾	Built-in by-pass contactor ⁽¹⁾ On PSTB)
•	•	•	Ramp Start/Stop
–	–	•	Torque control
–	–	•	Analog output

- Standard
- Optional
- Not available

Softstarters

Type PSR Overview



PSR3 ... PSR16

PSR25 ... PSR30

PSR37 ... PSR45

Softstarter, Type

Normal start:

In Line connected

(400 V) kW
IEC, Max. A

(440-480 V) hp
UL, Max. A

	PSR3	PSR6	PSR9	PSR12	PSR16	PSR25	PSR30	PSR37	PSR45
(400 V) kW	1.5	3	4	5.5	7.5	11	15	18.5	22
IEC, Max. A	3.9	6.8	9	12	16	25	30	37	45
(440-480 V) hp	2	3	5	7.5	10	15	20	25	30
UL, Max. A	3.4	6.1	9	11	15.2	24.2	28	34	46.2

400V, 40 °C

Manual motor starter, Type

If using manual motor starters type 1 coordination will be achieved.

	MS116	MS116	MS116	MS116	MS116	MS325	MS450	MS450	MS450

Fuse protection 400 V, 50 kA, gG Fuse

Using gG fuses type 1 coordination will be achieved.

	10 A	16 A	25 A	32 A	32 A	50 A	63 A	100 A	125 A

Switch fuse, Type

Suitable switch fuse for the above gG fuses.

	OS32D	OS32D	OS32D	OS32D	OS32D	OS32D	OS32D	OS63D	OS125D

Line contactor, Type

The line contactor is not required for the softstarter itself but often used to open if OL trips.

	A9	A9	A9	A12	A16	A26	A30	A40	A50

Thermal overload relay, Type

The overload relay is always required to protect the motor.

	TA25DU	TA25DU	TA25DU	TA25DU	TA25DU	TA25DU	TA25DU	TA42DU	TA75DU

By-pass contacts

	Built-in	Built-in	Built-in	Built-in	Built-in	Built-in	Built-in	Built-in	Built-in

Number of starts per hour using PSR softstarters

Motor-current I _e	Starts/hour without auxiliary fan								Starts/hour with auxiliary fan								
	10	20	30	40	50	60	80	100	10	20	30	40	50	60	80	100	
3 A	PSR3							PSR6	PSR3							PSR6	PSR9
6 A	PSR6				PSR9				PSR6				PSR9	PSR9			
9 A	PSR9		PSR12			PSR16	PSR25	PSR9		PSR12			PSR12				
12 A	PSR12		PSR16	PSR25		PSR30		PSR12		PSR16		PSR25		PSR12			
16 A	PSR16	PSR25		PSR30	PSR37			PSR16		PSR25			PSR30				
25 A	PSR25	PSR30	PSR37		PSR45		PSR60	PSR25		PSR30	PSR37		PSR45		PSR60		
30 A	PSR30	PSR37		PSR45		PSR60		PSR30		PSR37		PSR45					
37 A	PSR37	PSR45		PSR60		PSR72	PSR85	PSR105	PSR37		PSR45		PSR60				
45 A	PSR45		PSR60		PSR72	PSR85	PSR105	PSR45		PSR60		PSR72					
60 A	PSR60		PSR72	PSR85	PSR105	-			PSR60		PSR72		PSR85	PSR105	-		
72 A	PSR72	PSR85	PSR105		-			PSR72		PSR85		PSR105		-			
85 A	PSR85	PSR105		-			-			PSR85		PSR105		-			
105 A	PSR105	-			-			-			PSR105		-				

Data based on an ambient temperature of 40°, starting current of 4 x I_e and ramp time 6 seconds.

Softstarters

Type PSR

Overview and description



PSR60 ... PSR105

Softstarter, Type

PSR60	PSR72	PSR85	PSR105
30	37	45	55
60	72	85	105
40	50	60	75
59.4	68	80	104

400V, 40 °C

Manual motor starter, Type

MS495	MS495	MS495	—
-------	-------	-------	---

Fuse protection 400 V, 50 kA, gG Fuse

125 A	200 A	200 A	250 A
-------	-------	-------	-------

Switch fuse, Type

OS125D	OS250D	OS250D	OS250D
--------	--------	--------	--------

Line contactor, Type

A63	A75	A95	A110
-----	-----	-----	------

Thermal overload relay, Type

TA75DU	TA75DU	TA110DU	TA110DU
--------	--------	---------	---------

By-pass contacts

Built-in	Built-in	Built-in	Built-in
----------	----------	----------	----------

Description

PSR - Compact range, covers motor currents from 3 to 105 A. It is the latest addition to the softstarter family and has an attractive, compact design. Further, the system concept includes MMS and the softstarters are available for remote control connection using the FieldBusPlug as an accessory. All sizes include a Run signal relay, while from sizes 25 A the PSR Softstarters are also provided with an output signal for TOR (Top Of Ramp), i.e. full voltage. With standard performance the PSR Softstarters handle ten starts per hour. When an auxiliary cooling fan is added, the starting capacity is increased to 20 starts per hour or more.

- Current ratings 3.9 – 105 A (1.5 - 55 kW), at 400 V
- Motor voltage 208 – 600 V
- Supply voltage 24 V DC or 100-240 V AC
- Easy to install and adjust
- DIN rail or screw mounting
- Integrated by-pass contacts

With their compact design, the PSR Softstarters are ideal for installation in places where space is limited and where there is a demand for easy installation.

Settings

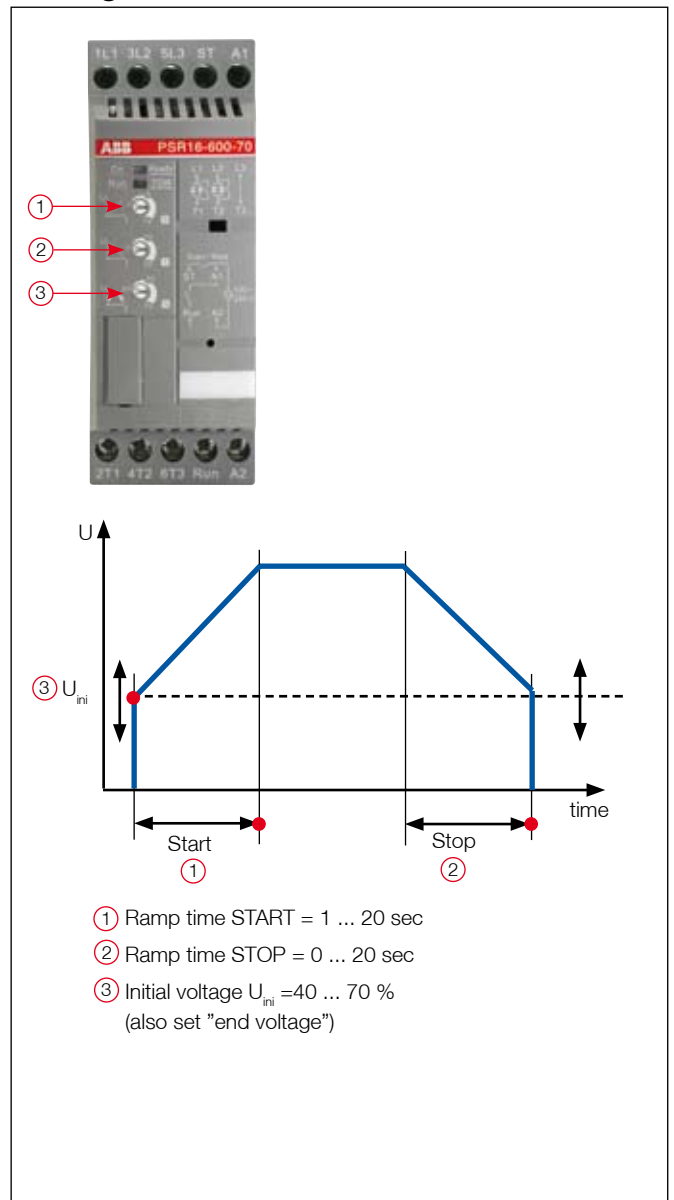

Softstarters

Type PSR3 ... PSR105

Ordering details



Motor power				IEC	Type	Order code	Weight kg 1 piece
230 V P_n kW	400 V P_n kW	500 V P_n kW	Max rated motor current, I_n A				
208 – 600 V AC							
Supply voltage, U_s 100-240 V AC							
0.75	1.5	2.2	3.9	PSR3-600-70	1SFA 896 103 R7000	0.45	
1.5	3	4	6.8	PSR6-600-70	1SFA 896 104 R7000	0.45	
2.2	4	4	9	PSR9-600-70	1SFA 896 105 R7000	0.45	
3	5.5	5.5	12	PSR12-600-70	1SFA 896 106 R7000	0.45	
4	7.5	7.5	16	PSR16-600-70	1SFA 896 107 R7000	0.45	
5.5	11	15	25	PSR25-600-70	1SFA 896 108 R7000	0.65	
7.5	15	18.5	30	PSR30-600-70	1SFA 896 109 R7000	0.65	
7.5	18.5	22	37	PSR37-600-70	1SFA 896 110 R7000	1.00	
11	22	30	45	PSR45-600-70	1SFA 896 111 R7000	1.00	
15	30	37	60	PSR60-600-70	1SFA 896 112 R7000	2.20	
22	37	45	72	PSR72-600-70	1SFA 896 113 R7000	2.27	
22	45	55	85	PSR85-600-70	1SFA 896 114 R7000	2.27	
30	55	55	105	PSR105-600-70	1SFA 896 115 R7000	2.27	
Supply voltage, U_s 24 V DC							
0.75	1.5	2.2	3.9	PSR3-600-81	1SFA 896 103 R8100	0.45	
1.5	3	4	6.8	PSR6-600-81	1SFA 896 104 R8100	0.45	
2.2	4	4	9	PSR9-600-81	1SFA 896 105 R8100	0.45	
3	5.5	5.5	12	PSR12-600-81	1SFA 896 106 R8100	0.45	
4	7.5	7.5	16	PSR16-600-81	1SFA 896 107 R8100	0.45	
5.5	11	15	25	PSR25-600-81	1SFA 896 108 R8100	0.65	
7.5	15	18.5	30	PSR30-600-81	1SFA 896 109 R8100	0.65	
7.5	18.5	22	37	PSR37-600-81	1SFA 896 110 R8100	1.00	
11	22	30	45	PSR45-600-81	1SFA 896 111 R8100	1.00	
15	30	37	60	PSR60-600-81	1SFA 896 112 R8100	2.20	
22	37	45	72	PSR72-600-81	1SFA 896 113 R8100	2.27	
22	45	55	85	PSR85-600-81	1SFA 896 114 R8100	2.27	
30	55	55	105	PSR105-600-81	1SFA 896 115 R8100	2.27	

Accessories

Description	Type	Order code	Pack ^{ing} piece	Weight kg 1 piece	
Fieldbus Plug Connection Accessory					
The same accessory for all sizes	PSR-FBPA	1SFA 896 312 R1001	1	0.06	
Connection kit for PSR3-16 and MS116	PSR16-MS116	1SFA 896 211 R1001	1	0.03	
Connection kit for PSR37-45 and MS450	PSR45-MS450	1SFA 896 213 R1001	1	0.03	
Connection kit for PSR60-105 and MS495	PSR105-MS495	1SAM 501 903 R1001	1	0.05	
Fan	PSR-FAN3-45A	1SFA 896 311 R1001	1	0.01	
Fan	PSR-FAN60-105A	1SFA 896 313 R1001	1	0.013	
Terminal enlargements for PSR60-105					
Wire range mm ²	1x10...50, 2x10...25	PSLW-72	1SFA 899 002 R1072	1	0.15

ABB Field Bus Plug

Suitable for all sizes. See page 32 - 34.

Softstarters

Type PSR3 ... PSR105

Technical data

Rated insulation voltage, U_i	600 V													
Rated operational voltage, U_e	208...600 V +10 %/-15 %, 50/60 Hz \pm 5%													
Rated supply voltage, U_s	100...240 V AC or 24 V DC +10 %/-15 %, 50/60 Hz \pm 5%													
Power consumption,	PSR3	PSR6	PSR9	PSR12	PSR16	PSR25	PSR30	PSR37	PSR45	PSR60	PSR72	PSR85	PSR105	
at 100-240 V AC	12 VA	12 VA	12 VA	12 VA	12 VA	12 VA	12 VA	10 VA	10 VA	10 VA	10 VA	10 VA	10 VA	
at 24 V DC	5 W	5 W	5 W	5 W	5 W	5 W	5 W	5 W	5 W	5 W	5 W	5 W	5 W	
Rated operational current, I_r	PSR3	PSR6	PSR9	PSR12	PSR16	PSR25	PSR30	PSR37	PSR45	PSR60	PSR72	PSR85	PSR105	
	3.9 A	6.8 A	9 A	12 A	16 A	25 A	30 A	37 A	45 A	60 A	72 A	85 A	105 A	
Starting capacity at I_r	4 x I_r for 6 sec.													
Number of starts per hour,														
standard	10 (4 x I_e during 6 s) See table on page 6 for details.													
with aux. fan	>20 (4 x I_e during 6 s)													
Service factor	100 %													
Ambient temperature														
during operation ¹⁾	-25 °C to +60 °C													
during storage	-40 °C to +70 °C													
Maximum altitude ²⁾	4000 m													
Degree of protection,	PSR3	PSR6	PSR9	PSR12	PSR16	PSR25	PSR30	PSR37	PSR45	PSR60	PSR72	PSR85	PSR105	
main circuit	IP20	IP20	IP20	IP20	IP20	IP20	IP20	IP10	IP10	IP10	IP10	IP10	IP10	
control circuit	IP20	IP20	IP20	IP20	IP20	IP20	IP20	IP20	IP20	IP20	IP20	IP20	IP20	
Connectable cable area,	PSR3 - PSR16					PSR25 - PSR30			PSR37 - PSR45		PSR60 - PSR105			
main circuit	1 x 0.75 - 2.5 mm ²					1 x 2.5 - 10 mm ²			1 x 6 - 35 mm ²		1 x 10 - 95 mm ²			
	2 x 0.75 - 2.5 mm ²					2 x 2.5 - 10 mm ²			2 x 6 - 16 mm ²		2 x 6 - 35 mm ²			
control circuit	PSR3 - PSR16					PSR25 - PSR105								
	1 x 0.75 - 2.5 mm ²					1 x 0.75 - 2.5 mm ²								
	2 x 0.75 - 2.5 mm ²					2 x 0.75 - 1.5 mm ²								
Signal relays	PSR3 - PSR16					PSR25 - PSR105								
for Run signal														
Resistive load	240 V, 2 A					250 V, 5 A								
AC-15 (Contactor)	240 V, 0.5 A					250 V, 0.5 A								
for Top of Ramp signal														
Resistive load	-					250 V, 2 A								
AC-15 (Contactor)	-					250 V, 0.5 A								
LED														
for On/Ready	Green													
for Run/Top Of Ramp	Green													
Settings														
Ramp time during start	1-20 sec.													
Ramp time during stop	0-20 sec.													
Initial- and End Voltage	40-70%													

¹⁾ Above 40 °C up to max. 60 °C reduce the rated current with 0.8 % per °C.

²⁾ When used at high altitudes above 1000 meters up to 4000 meters you need to derate the rated current using the following formula.

$$[\% \text{ of } I_e = 100 - \frac{x - 1000}{150}]$$

x = actual altitude for the softstarter

UL ratings

Softstarter	Motor power P (hp) and full load current FLA (A)					Max. fuse A, Type
	FLA A	U_e 200 V/208 V hp	U_e 220 V/240 V hp	U_e 440 V/480 V hp	U_e 550 V/600V hp	
PSR3	3.4	0.5	0.75	2	2	35 A J-Type
PSR6	6.1	1	1.5	3	5	35 A J-Type
PSR9	9	2	2	5	7.5	35 A J-Type
PSR12	11	3	3	7.5	10	35 A J-Type
PSR16	15.2	3	5	10	10	35 A J-Type
PSR25	24.2	7.5	7.5	15	20	60 A J-Type
PSR30	28	7.5	10	20	25	60 A J-Type
PSR37	34	10	10	25	30	90 A J-Type
PSR45	46.2	15	15	30	40	90 A J-Type
PSR60	59.4	20	20	40	50	110 A J-Type
PSR72	68	20	25	50	60	125 A J-Type
PSR85	80	25	30	60	75	150 A J-Type
PSR105	104	30	40	75	100	200 A J-Type

Softstarters

Type PSS Overview



PSS18/30 ... PSS44/76

PSS50/85 ... PSS72/124

Softstarter, Type

Normal start:

In Line connected

(400 V) kW
IEC, Max. A

(440-480 V) hp
UL, Max. A

	PSS18/30	PSS30/52	PSS37/64	PSS44/76	PSS50/85	PSS60/105	PSS72/124
(400 V) kW	7.5	15	18.5	22	25	30	37
IEC, Max. A	18	30	37	44	50	60	72
(440-480 V) hp	10	20	25	30	30	40	50
UL, Max. A	18	28	34	40	47	56	67

400V, 40 °C

MCCB (50 kA), Type

If using MCCB only, type 1 coordination will be achieved.

	T2S160	T2S160	T2S160	T2S160	T2S160	T2S160	T2S160
	T2S160	T2S160	T2S160	T2S160	T2S160	T2S160	T2S160

Fuse protection (65 kA) Semiconductor fuses, Bussmann, Type

To achieve a type 2 coordination, semi-conductor fuses must be used.

	170M1364	170M1366	170M1368	170M1369	170M1369	170M1370	170M1371
	170M1364	170M1366	170M1368	170M1369	170M1369	170M1370	170M1371

Switch fuse, Type

Suitable switch fuse for recommended semi-conductor fuses.

	OS160RD0380	OS160RD0380	OS160RD0380	OS160RD0380	OS160RD0380	OS160RD0380	OS160RD0380
	OS160RD0380	OS160RD0380	OS160RD0380	OS160RD0380	OS160RD0380	OS160RD0380	OS160RD0380

Line contactor, Type

The line contactor is not required for the softstarter itself but often used to open if OL trips.

	A26	A30	A40	A50	A50	A63	A75
	A26	A30	A40	A50	A50	A63	A75

Thermal overload relay, Type

The overload relay is always required to protect the motor.

	TA25DU	TA25DU	TA42DU	TA75DU	TA75DU	TA75DU	TA75DU
	TA25DU	TA25DU	TA42DU	TA75DU	TA75DU	TA75DU	TA75DU

By-pass contactor, Type

The by-pass contactor can be used to reduce the power loss of the softstarter but also to increase the number of starts/h. All softstarters can be operated without by-pass.

	A9	A16	A26	A26	A30	A40	A50
	A9	A16	A26	A26	A30	A40	A50

Current transformers, Type

Must be used if current limit function is required.

	PSCT-60 2 turns	PSCT-40 1 turn	PSCT-50 1 turn	PSCT-60 1 turn	PSCT-75 1 turn	PSCT-75 1 turn	PSCT-100 1 turn
	PSCT-60 2 turns	PSCT-40 1 turn	PSCT-50 1 turn	PSCT-60 1 turn	PSCT-75 1 turn	PSCT-75 1 turn	PSCT-100 1 turn

The table above is an overview of possible combinations of devices.
Complete coordination tables are available at www.abb.com/lowvoltage.

Softstarters

Type PSS

Overview



1SFT9889-038



1SFT9890-004

PSS85/147... PSS142/245

PSS175/300... PSS300/515

Softstarter, Type

PSS85/147	PSS105/181	PSS142/245	PSS175/300	PSS250/430	PSS300/515
45	55	75	90	132	160
85	105	142	175	250	300
60	75	100	125	150	200
85	105	125	156	225	248

400V, 40 °C

MCCB (50 kA), Type

T2S160	T3S250	T3S250	T3S250	T4S320	T5S400

Fuse protection (65 kA) Semiconductor fuses, Bussmann, Type

170M1372	170M3019	170M3020	170M3021	170M5013	170M5015

Switch fuse, Type

OS160RD0380	OESA250R03D80	OESA250R03D80	OESA250R03D80	OESA400R03D80	OESA400R03D80

Line contactor, Type

A95	A110	A145	A185	A260	A300

Thermal overload relay, Type

TA110DU	TA110DU	TA200DU	TA200DU	TA450DU	TA450DU

By-pass contactor, Type

A50	A63	A95	A145	A145	A210

Current transformers, Type

PSCT-125	PSCT-150	PSCT-200	PSCT-250	PSCT-400	PSCT-400
1 turn	1 turn	1 turn	1 turn	1 turn	1 turn

How to select correct size

By using the guide beside, you can quickly select a suitable softstarter for the most common applications.

If a more precise selection is required, you can use Prosoft, a selection software available at www.abb.com/lowvoltage.

Quick guide for selection



Normal start Class 10

Ordering – See page 14 –15

Typical applications

- Bow thruster
- Compressor
- Elevator
- Centrifugal pump
- Conveyor belt (short)
- Escalator

Heavy duty start Class 30

Ordering – See page 16 –17

Typical applications

- Centrifugal fan
- Crusher
- Mixer
- Conveyor belt (long)
- Mill
- Stirrer

If more than 10 starts /h

! Select **one** size larger than the standard selection.

Softstarters

Type PSS18/30 ... PSS300/515

Application and Description

Application

The softstarter range PSS18/30 ... PSS300/515 is a very flexible solution suitable for most applications and for replacements of Star-Delta starters. Since the unit can be connected inside the motor delta (compare the connection for standard Star-Delta starters), the current through the softstarter is reduced by 42 %. It will then be possible, for example, to run a 100 A motor using a 58 A PSS Softstarter.

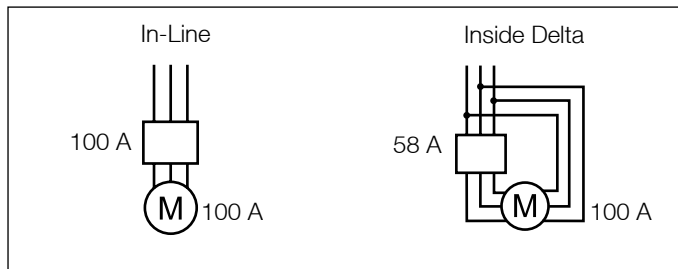

In-Line and Inside Delta connection of PSS18/30 ... PSS300/515

The PSS Softstarter can be selected according to the rated motor power in **normal duty** applications like pumps, compressors, elevators, escalators, short conveyor belts and bow thrusters – see page 14-15.

For **heavy duty** applications like centrifugal fans, crushers, mixers, mills, stirrers and long conveyor belts, select a softstarter from page 16-17.

Description

- Wide main voltage range 208 - 690 V AC
- Supply voltage range 110-120 V AC and 220-240 V AC
- Current ratings 18 ... 300 A (In Line) and 30 ... 515 A (Inside Delta)
- Same unit can be used for both In Line and Inside Delta connection
- Start ramp, Stop ramp and Initial voltage included
- Current limit function as option
- Solid state electrical circuit
- Designed for continuous operation without by-pass
- 15 % overcurrent capability during continuous run (10 % for PSS300/515)
- Accessories for connection and installation available: See the ordering pages

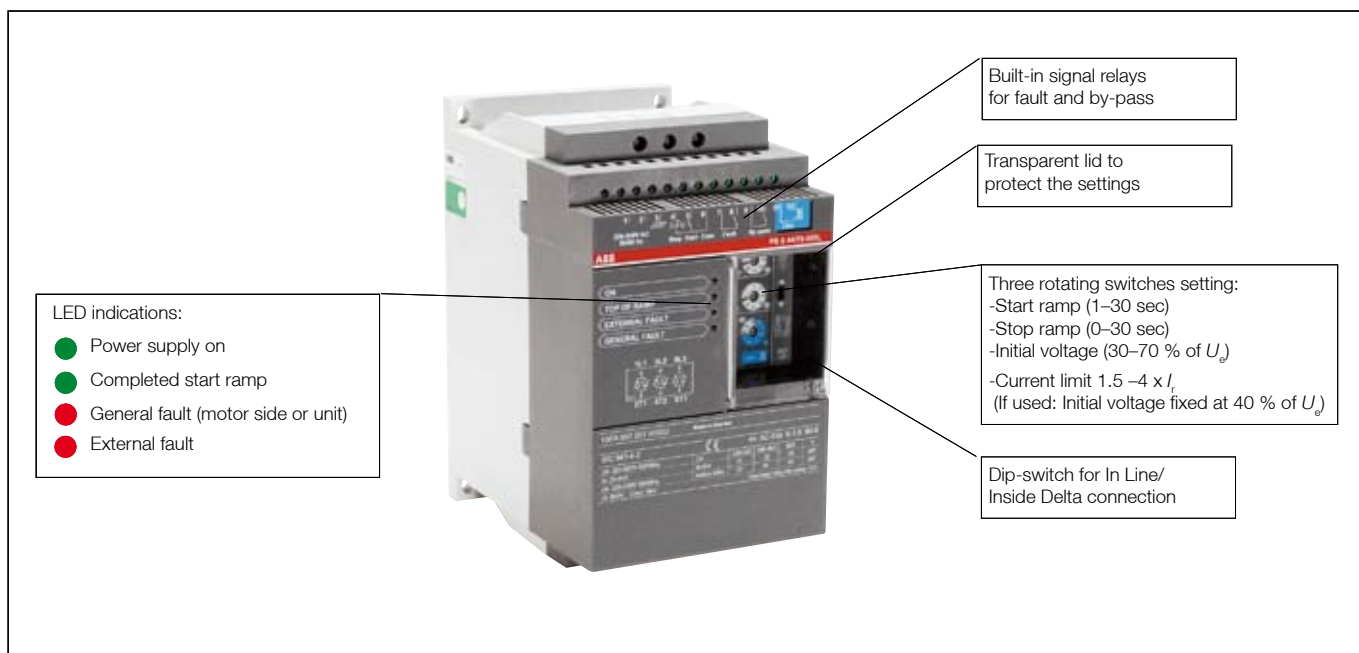

Softstarters

Type PSS18/30 ... PSS300/515



Different sizes of PSS, from left PSS175/300-500L, PSS85/147-500L, PSS50/85-500L and in the front PSS18/30-500L.

Settings

PSS18/30 ... PSS300/515

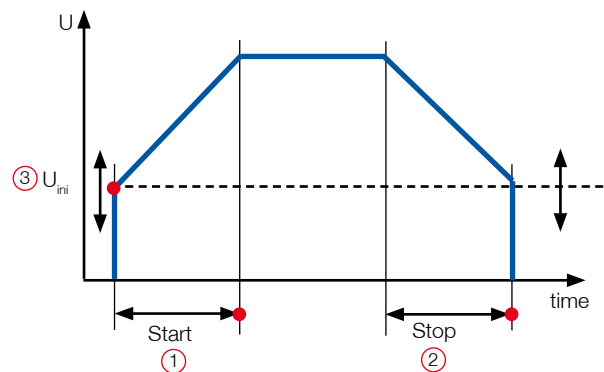
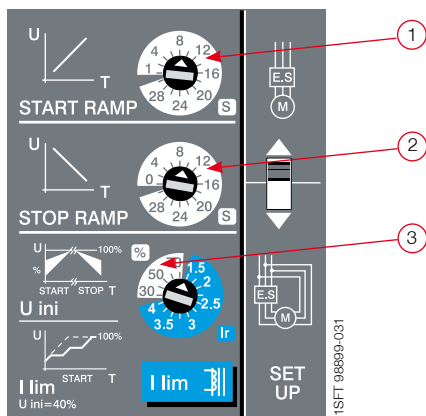

- ① Ramp time START = 1 ... 30 sec
- ② Ramp time STOP = 0 ... 30 sec
- ③ Initial voltage U_{ini} = 40 ... 70 %, when current limit is used fixed at 40 % (also set "end voltage")

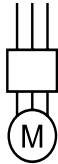

Softstarters

Type PSS18/30 ... PSS300/515

Normal starts, class 10 – In-Line, Ordering details



1SFT089893.C06

PSS18/30-500 ... 44/76-500



1SFT089893.C07

PSS50/85-500 ... 72/124-500
PSS18/30-690 ... 72/124-690



1SFT089893.C08

PSS85/147-500 ... 142/245-500
PSS85/147-690 ... 142/245-690



1SFT089893.C04

PSS175/300-500 ... 300/515-500
PSS175/300-690 ... 300/515-690

PSS18/30 ... PSS300/515

230 – 500 V

Motor power

400 V P_n kW	500 V P_n kW	690 V P_n kW	Rated motor current, I_n A	Type ¹⁾	Order code ²⁾	Weight kg
7.5	11	-	18	PSS18/30-500	1SFA 892 001 R▽00▽	2.30
15	18.5	-	30	PSS30/52-500	1SFA 892 002 R▽00▽	2.30
18.5	22	-	37	PSS37/64-500	1SFA 892 003 R▽00▽	2.30
22	25	-	44	PSS44/76-500	1SFA 892 004 R▽00▽	2.30
25	30	-	50	PSS50/85-500	1SFA 892 005 R▽00▽	3.60
30	37	-	60	PSS60/105-500	1SFA 892 006 R▽00▽	3.80
37	45	-	72	PSS72/124-500	1SFA 892 007 R▽00▽	3.80
45	55	-	85	PSS85/147-500	1SFA 892 008 R▽00▽	8.60
55	75	-	105	PSS105/181-500	1SFA 892 009 R▽00▽	10.40
75	90	-	142	PSS142/245-500	1SFA 892 010 R▽00▽	10.40
90	110	-	175	PSS175/300-500	1SFA 892 011 R▽00▽	20.50
132	160	-	250	PSS250/430-500	1SFA 892 013 R▽00▽	22.00
160	200	-	300	PSS300/515-500	1SFA 892 014 R▽00▽	22.00

400 – 690 V

Motor power

400 V P_n kW	500 V P_n kW	690 V P_n kW	Rated motor current, I_n A	Type ¹⁾	Order code ²⁾	Weight kg
7.5	11	15	18	PSS18/30-690	1SFA 893 001 R▽00▽	2.30
15	18.5	25	30	PSS30/52-690	1SFA 893 002 R▽00▽	2.30
18.5	22	30	37	PSS37/64-690	1SFA 893 003 R▽00▽	2.30
22	25	37	44	PSS44/76-690	1SFA 893 004 R▽00▽	2.30
25	30	45	50	PSS50/85-690	1SFA 893 005 R▽00▽	3.60
30	37	55	60	PSS60/105-690	1SFA 893 006 R▽00▽	3.80
37	45	59	72	PSS72/124-690	1SFA 893 007 R▽00▽	3.80
45	55	75	85	PSS85/147-690	1SFA 893 008 R▽00▽	8.60
55	75	90	105	PSS105/181-690	1SFA 893 009 R▽00▽	10.40
75	90	132	142	PSS142/245-690	1SFA 893 010 R▽00▽	10.40
90	110	160	175	PSS175/300-690	1SFA 893 011 R▽00▽	20.50
132	160	220	250	PSS250/430-690	1SFA 893 013 R▽00▽	22.00
160	200	257	300	PSS300/515-690	1SFA 893 014 R▽00▽	22.00

¹⁾ Add code letter in Type for:

Supply voltage, U_s

- F = 110-120 V, 50/60 Hz
- L = 220-240 V, 50/60 Hz

Fault signal relay

- no code letter = NO
- C = NC

²⁾ Add code number in Order code for:

Fault signal relay

- ▽ 1 = NO
- 2 = NC

Supply voltage, U_s

- ▽ 1 = 110-120 V, 50/60 Hz
- 2 = 220-240 V, 50/60 Hz

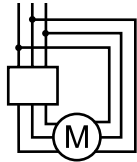

Softstarters

Type PSS18/30 ... PSS300/515

Normal starts, class 10 – Inside Delta, Ordering details



PSS18/30-500 ... 44/76-500

1SFT198889-036



PSS50/85-500 ... 72/124-500
PSS18/30-690 ... 72/124-690

1SFT198889-037



PSS85/147-500 ... 142/245-500
PSS85/147-690 ... 142/245-690

1SFT198889-038



PSS175/300-500 ... 300/515-500
PSS175/300-690 ... 300/515-690

1SFT198900-004

PSS18/30 ... PSS300/515

230 – 500 V

Motor power

400 V P_o kW	500 V P_o kW	690 V P_o kW	Rated motor current, I_o A	Type ¹⁾	Order code ²⁾	Weight kg
15	18.5	-	30	PSS18/30-500	1SFA 892 001 R▽00	2.30
25	30	-	52	PSS30/52-500	1SFA 892 002 R▽00	2.30
30	37	-	64	PSS37/64-500	1SFA 892 003 R▽00	2.30
37	45	-	76	PSS44/76-500	1SFA 892 004 R▽00	2.30
45	55	-	85	PSS50/85-500	1SFA 892 005 R▽00	3.60
55	75	-	105	PSS60/105-500	1SFA 892 006 R▽00	3.80
59	80	-	124	PSS72/124-500	1SFA 892 007 R▽00	3.80
75	90	-	147	PSS85/147-500	1SFA 892 008 R▽00	8.60
90	110	-	181	PSS105/181-500	1SFA 892 009 R▽00	10.40
132	160	-	245	PSS142/245-500	1SFA 892 010 R▽00	10.40
160	200	-	300	PSS175/300-500	1SFA 892 011 R▽00	20.50
220	295	-	430	PSS250/430-500	1SFA 892 013 R▽00	22.00
257	355	-	515	PSS300/515-500	1SFA 892 014 R▽00	22.00

400 – 690 V

Motor power

400 V P_o kW	500 V P_o kW	690 V P_o kW	Rated motor current, I_o A	Type ¹⁾	Order code ²⁾	Weight kg
15	18.5	25	30	PSS18/30-690	1SFA 893 001 R▽00	2.30
25	30	45	52	PSS30/52-690	1SFA 893 002 R▽00	2.30
30	37	55	64	PSS37/64-690	1SFA 893 003 R▽00	2.30
37	45	59	76	PSS44/76-690	1SFA 893 004 R▽00	2.30
45	55	75	85	PSS50/85-690	1SFA 893 005 R▽00	3.60
55	75	90	105	PSS60/105-690	1SFA 893 006 R▽00	3.80
59	80	110	124	PSS72/124-690	1SFA 893 007 R▽00	3.80
75	90	132	147	PSS85/147-690	1SFA 893 008 R▽00	8.60
90	110	160	181	PSS105/181-690	1SFA 893 009 R▽00	10.40
132	160	220	245	PSS142/245-690	1SFA 893 010 R▽00	10.40
160	200	257	300	PSS175/300-690	1SFA 893 011 R▽00	20.50
220	295	400	430	PSS250/430-690	1SFA 893 013 R▽00	22.00
257	355	500	515	PSS300/515-690	1SFA 893 014 R▽00	22.00

¹⁾ Add code letter in Type for:
Supply voltage, U_s

- F = 110-120 V, 50/60 Hz
- L = 220-240 V, 50/60 Hz

Fault signal relay

- no code letter = NO
- C = NC

²⁾ Add code number in Order code for:
Fault signal relay

- 1 = NO
- 2 = NC

Supply voltage, U_s

- 1 = 110-120 V, 50/60 Hz
- 2 = 220-240 V, 50/60 Hz

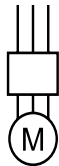

Softstarters

Type PSS30/52 ... PSS300/515

Heavy duty starts, class 30 – In-Line, Ordering details



PSS30/52 ... PSS300/515

230 – 500 V

Motor power

400 V P_o kW	500 V P_o kW	690 V P_o kW	Rated motor current, I_o A	Type ¹⁾	Order code ²⁾	Weight kg
7.5	11	-	18	PSS30/52-500□■	1SFA 892 002 R▽00▽	2.30
15	18.5	-	30	PSS37/64-500□■	1SFA 892 003 R▽00▽	2.30
18.5	22	-	37	PSS44/76-500□■	1SFA 892 004 R▽00▽	2.30
22	25	-	44	PSS50/85-500□■	1SFA 892 005 R▽00▽	3.60
25	30	-	50	PSS60/105-500□■	1SFA 892 006 R▽00▽	3.80
30	37	-	60	PSS72/124-500□■	1SFA 892 007 R▽00▽	3.80
37	45	-	72	PSS85/147-500□■	1SFA 892 008 R▽00▽	8.60
45	55	-	85	PSS105/181-500□■	1SFA 892 009 R▽00▽	10.40
55	75	-	105	PSS142/245-500□■	1SFA 892 010 R▽00▽	10.40
75	90	-	142	PSS175/300-500□■	1SFA 892 011 R▽00▽	20.50
90	110	-	175	PSS250/430-500□■	1SFA 892 013 R▽00▽	22.00
132	160	-	250	PSS300/515-500□■	1SFA 892 014 R▽00▽	22.00

400 – 690 V

Motor power

400 V P_o kW	500 V P_o kW	690 V P_o kW	Rated motor current, I_o A	Type ¹⁾	Order code ²⁾	Weight kg
7.5	11	15	18	PSS30/52-690□■	1SFA 893 002 R▽00▽	2.30
15	18.5	25	30	PSS37/64-690□■	1SFA 893 003 R▽00▽	2.30
18.5	22	30	37	PSS44/76-690□■	1SFA 893 004 R▽00▽	2.30
22	25	37	44	PSS50/85-690□■	1SFA 893 005 R▽00▽	3.60
25	30	45	50	PSS60/105-690□■	1SFA 893 006 R▽00▽	3.80
30	37	55	60	PSS72/124-690□■	1SFA 893 007 R▽00▽	3.80
37	45	59	72	PSS85/147-690□■	1SFA 893 008 R▽00▽	8.60
45	55	75	85	PSS105/181-690□■	1SFA 893 009 R▽00▽	10.40
55	75	90	105	PSS142/245-690□■	1SFA 893 010 R▽00▽	10.40
75	90	132	142	PSS175/300-690□■	1SFA 893 011 R▽00▽	20.50
90	110	160	175	PSS250/430-690□■	1SFA 893 013 R▽00▽	22.00
132	160	220	250	PSS300/515-690□■	1SFA 893 014 R▽00▽	22.00

¹⁾ Add code letter in Type for:

Supply voltage, U_s

- F = 110-120 V, 50/60 Hz
- L = 220-240 V, 50/60 Hz

Fault signal relay

- no code letter = NO
- C = NC

²⁾ Add code number in Order code for:

Fault signal relay

- ▽ 1 = NO
- ▽ 2 = NC

Supply voltage, U_s

- ▽ 1 = 110-120 V, 50/60 Hz
- ▽ 2 = 220-240 V, 50/60 Hz



PSS30/52-500 ... 44/76-500

1SFT0889-036



PSS50/85-500 ... 72/124-500
PSS18/30-690 ... 72/124-690

1SFT0889-037



PSS85/147-500 ... 142/245-500
PSS85/147-690 ... 142/245-690

1SFT0889-038



PSS175/300-500 ... 300/515-500
PSS175/300-690 ... 300/515-690

1SFT0889-034

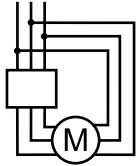

Softstarters

Type PSS30/52 ... PSS300/515

Heavy duty starts, class 30 – Inside Delta, Ordering details



PSS30/52 ... PSS300/515

230 – 500 V

Motor power

400 V P_o kW	500 V P_o kW	690 V P_o kW	Rated motor current, I_o A	Type ¹⁾	Order code ²⁾	Weight kg
15	18,5	-	30	PSS30/52-500	1SFA 892 002 R▽00	2.30
25	30	-	52	PSS37/64-500	1SFA 892 003 R▽00	2.30
30	37	-	64	PSS44/76-500	1SFA 892 004 R▽00	2.30
37	45	-	76	PSS50/85-500	1SFA 892 005 R▽00	3.60
45	55	-	85	PSS60/105-500	1SFA 892 006 R▽00	3.80
55	75	-	105	PSS72/124-500	1SFA 892 007 R▽00	3.80
59	80	-	124	PSS85/147-500	1SFA 892 008 R▽00	8.60
75	90	-	147	PSS105/181-500	1SFA 892 009 R▽00	10.40
90	110	-	181	PSS142/245-500	1SFA 892 010 R▽00	10.40
132	160	-	245	PSS175/300-500	1SFA 892 011 R▽00	20.50
160	200	-	300	PSS250/430-500	1SFA 892 013 R▽00	22.00
220	295	-	430	PSS300/515-500	1SFA 892 014 R▽00	22.00

400 – 690 V

Motor power

400 V P_o kW	500 V P_o kW	690 V P_o kW	Rated motor current, I_o A	Type ¹⁾	Order code ²⁾	Weight kg
15	18,5	25	30	PSS30/52-690	1SFA 893 002 R▽00	2.30
25	30	45	52	PSS37/64-690	1SFA 893 003 R▽00	2.30
30	37	55	64	PSS44/76-690	1SFA 893 004 R▽00	2.30
37	45	59	76	PSS50/85-690	1SFA 893 005 R▽00	3.60
45	55	75	85	PSS60/105-690	1SFA 893 006 R▽00	3.80
55	75	90	105	PSS72/124-690	1SFA 893 007 R▽00	3.80
59	80	110	124	PSS85/147-690	1SFA 893 008 R▽00	8.60
75	90	132	147	PSS105/181-690	1SFA 893 009 R▽00	10.40
90	110	160	181	PSS142/245-690	1SFA 893 010 R▽00	10.40
132	160	220	245	PSS175/300-690	1SFA 893 011 R▽00	20.50
160	200	257	300	PSS250/430-690	1SFA 893 013 R▽00	22.00
220	295	400	430	PSS300/515-690	1SFA 893 014 R▽00	22.00

¹⁾ Add code letter in Type for:
Supply voltage, U_s
□ F = 110-120 V, 50/60 Hz
L = 220-240 V, 50/60 Hz
Fault signal relay
■ no code letter = NO
C = NC

²⁾ Add code number in Order code for:
Fault signal relay
▽ 1 = NO
2 = NC
Supply voltage, U_s
▽ 1 = 110-120 V, 50/60 Hz
2 = 220-240 V, 50/60 Hz



PSS30/52-500 ... 44/76-500

1SFT98889-038



PSS50/85-500 ... 72/124-500
PSS18/30-690 ... 72/124-690

1SFT98889-037



PSS85/147-500 ... 142/245-500
PSS85/147-690 ... 142/245-690

1SFT98889-038



PSS175/300-500 ... 300/515-500
PSS175/300-690 ... 300/515-690

1SFT98900-004

Softstarters

Accessories for type PSS18/30 ... PSS300/515

Ordering details

Current transformer for current limit function

To be connected to terminals 11 and 12 on the softstarter.

The setting range (1.5 – 4) corresponds to a multiple of the transformer ratio.

Technical data below shows transformer ratio and number of turns for the primary winding.

You can also use your own current transformer with corresponding transformer ratio and with minimum 1 VA.

For softstarter type	Transformer ratio, Number of turns	Type	Order code	Pack ^{ing} piece	Weight
					kg
PSS18/30	60/1 – 2 turns	PSCT-60	1SFA 899 001 R1060	1	0.30
PSS30/52	40/1 – 1 turn	PSCT-40	1SFA 899 001 R1040	1	0.30
PSS37/64	50/1 – 1 turn	PSCT-50	1SFA 899 001 R1050	1	0.30
PSS44/76	60/1 – 1 turn	PSCT-60	1SFA 899 001 R1060	1	0.30
PSS50/85	75/1 – 1 turn	PSCT-75	1SFA 899 001 R1075	1	0.30
PSS60/105	75/1 – 1 turn	PSCT-75	1SFA 899 001 R1075	1	0.30
PSS72/124	100/1 – 1 turn	PSCT-100	1SFA 899 001 R1100	1	0.25
PSS85/147	125/1 – 1 turn	PSCT-125	1SFA 899 001 R1125	1	0.25
PSS105/181	150/1 – 1 turn	PSCT-150	1SFA 899 001 R1150	1	0.25
PSS142/245	200/1 – 1 turn	PSCT-200	1SFA 899 001 R1200	1	0.25
PSS175/300	250/1 – 1 turn	PSCT-250	1SFA 899 001 R1250	1	0.25
PSS250/430	400/1 – 1 turn	PSCT-400	1SFA 899 001 R1400	1	0.25
PSS300/515	400/1 – 1 turn	PSCT-400	1SFA 899 001 R1400	1	0.25

Cable connectors for Cu cables

For softstarter type	Wire range mm ²	Tightening torque max. Nm	Type	Order code	Pack ^{ing} piece	Weight
						kg
PSS85/147...142/245	6-185	16	–	1SDA 023 354 R0001	3	0.20
PSS85/147...142/245	2x(50-120)	16	LZ185-2C/120	1SFN 074 709 R1000	3	0.30
PSS175/300...300/515	16-240	25	–	1SDA 023 368 R0001	3	0.40

Cable connectors for Al and Cu cables

For softstarter type	Wire range mm ²	Tightening torque max. Nm	Type	Order code	Pack ^{ing} piece	Weight
						kg
PSS85/147...142/245	35-95	13.5	–	1SDA 023 356 R0001	3	0.10
PSS85/147...142/245	25-150	31	–	1SDA 023 357 R0001	3	0.10
PSS175/300...300/515	120-240	43	–	1SDA 023 370 R0001	3	0.10

Terminal enlargements

For softstarter type	Wire range mm ²	Type	Order code	Pack ^{ing} piece	Weight
					kg
PSS18/30-500 ...44/76-500	1x6...35 2x6...16	PSLW-44	1SFA 899 002 R1044	1	0.10
PSS50/85-500...72/124-500					
PSS18/30-690 ... 72/124-690	1x10...50 2x10...25	PSLW-72	1SFA 899 002 R1072	1	0.15
PSS85/147...142/245		LW185	1SFN 074 707 R1000	1	0.25
PSS175/300...300/515		LW300	1SFN 075 107 R1000	1	0.40

Terminal nut washer

For softstarter type	Type	Order code	Pack ^{ing} piece	Weight
				kg
PSS85/147...142/245	LE185	1SFN 074 716 R1000	2	0.20
PSS175/300...300/515	LE300	1SFN 075 116 R1000	2	0.30

Terminal shrouds

For softstarter type	Suitable for	Type	Order code	Pack ^{ing} piece	Weight
					kg
PSS85/147...142/245	Cable connectors	LT185-AC	1SFN 124 701 R1000	2	0.10
PSS85/147...142/245	Compression lugs	LT185-AL	1SFN 124 703 R1000	2	0.10
PSS175/300...300/515	Cable connectors	LT300-AC	1SFN 125 101 R1000	2	0.20
PSS175/300...300/515	Compression lugs	LT300-AL	1SFN 125 103 R1000	2	0.20



Softstarters

Type PSS18/30 ... PSS300/515

Technical data

PSS18/30 ... PSS300/515		
Rated insulation voltage, U_i	690 V	
Rated operational voltage, U_e	208 – 690 V +10 %/-15 %, 50/60 Hz ±5 %	
Starting capacity	at max. rated current, I _e 4 x I _e for 10 sec	
Number of starts per hour	30 ³⁾	
Overload capability	Overload class 10	
Service factor	PSS18/30 ... 250/430 115 %	PSS300/515 110 %
Ambient temperature	During operation -25 to +60 °C ¹⁾ During storage -40 to +70 °C	
Maximum altitud ⁴⁾	4000 m	
Degree of protection	PSS18/30-500 ... 44/76-500 IP 20	PSS50/85-500 ... 72/124-500 IP 10
Main circuit	PSS18/30-690 ... 72/124-690 IP 10	PSS85/147-690 ... 300/515-690 IP 00
Supply and control circuit	PSS18/30...PSS300/515 IP 20	
Supply circuit	Supply voltage, U _s 110-120 V or 220-240 V +10 %/-15 %, 50/60 Hz ±5 %	
Settings	Ramp time during start 1 – 30 sec Ramp time during stop 0 – 30 sec Initial voltage during start 30 – 70 % Current limit function x CT-ratio 1.5 ... 4 ²⁾	
Switch for	Inside Delta connection ON/OFF Yes	
Signal relays	By-pass signal Yes Fault signal Yes (NO or NC) Rated operational voltage, U _e 250V Rated thermal current, I _{th} 5A Rated operational current, I _e at AC-15 (U _e =250 V) 1.5A	
Signal indication LED	Ready to start/stand by ON Green Ramping up/down – Completed start ramp T.O.R Green General fault Red External fault Red	

¹⁾ Above 40 °C, up to max 60 °C, reduce the rated current with 0.8 % per °C.

²⁾ Only if current transformer is connected (accessory).

³⁾ Valid for 50 % on time and 50 % off time. 3.5 x I_e for 7 sec., if other data is required, contact your sales office.

⁴⁾ When used at high altitudes above 1000 meters up to 4000 meters you need to derate rated current using the following formula.

$$\left[\% \text{ of } I_e = 100 - \frac{x - 1000}{150} \right]$$

x = actual altitude for the softstarter

Softstarters

Type PSS18/30 ... PSS300/515

Technical data

Cross section of connection cables

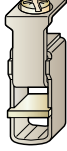
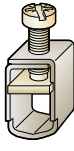
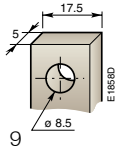
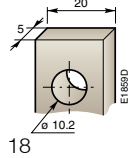
		Type of softstarter			
		PSS 18/30-500 ... 44/76-500	PSS50/85-500 ... 72/124-500, 18/30-690 ... 72/124-690	PSS85/147-500 ... 142/245-500, 85/147-690 ... 142/245-690	PSS175/300 ... 300/515-500, 175/300 ... 300/515-690
Main circuit					
Connection clamp					
					
Solid/Stranded	1 x mm ²	2.5 – 16	6 – 50	See accessories	See accessories
Solid/Stranded	2 x mm ²	2.5 – 16	6 – 25	See accessories	See accessories
Tightening torque (recommended)	Nm	2.6	4.5	See accessories	See accessories
Connection bar					
Width and thickness	mm	–	–		
Hole diameter	mm	–	–	9	18
Tightening torque (recommended)	Nm	–	–	–	–
Supply and control circuit					
Connection clamp					
Solid/Stranded	1 x mm ²	2.5	2.5	2.5	2.5
Solid/Stranded	2 x mm ²	–	–	–	–
Tightening torque (recommended)	Nm	0.5	0.5	0.5	0.5

Fuse ratings and power losses

For Softstarter	Recommended ABB Overload protection	Current range	Max power loss at rated I _e		Max fuse rating - main circuit ¹⁾				Power requirements of supply	
			without by-pass ²⁾	with external by-pass	Bussman fuses			Ferraz fuses/circuit		
					A	Type	Holder	A		Type
PSS18/30	TA 25 DU	6–18	65	13.5	50	170M1364	170H1007	63	6.6 URB 000 D08 V 0063	9
PSS30/52	TA 25 DU	10–30	100	14.6	80	170M1366	170H1007	100	6.6 URB 000 D08 V 0100	9
PSS37/64	TA 42 DU	22–37	120	17.5	125	170M1368	170H1007	160	6.6 URB 000 D08 V 0160	9
PSS44/76	TA 75 DU	29–44	142	17.5	160	170M1369	170H1007	200	6.6 URD 30 D08 A 0200	9
PSS50/85	TA 75 DU	29–50	160	20.5	160	170M1369	170H1007	200	6.6 URD 30 D08 A 0200	10
PSS60/105	TA 75 DU	29–60	190	22	200	170M1370	170H1007	250	6.6 URD 30 D08 A 0250	10
PSS72/124	TA 75 DU	45–72	226	30.5	250	170M1371	170H1007	315	6.6 URD 30 D08 A 0315	10
PSS85/147	TA 110 DU	65–85	291	56.5	315	170M1372	170H1007	400	6.6 URD 30 D08 A 0400	36
PSS105/181	TA 110 DU	65–105	351	61	400	170M3019	170H3004	400	6.6 URD 30 D08 A 0400	36
PSS142/245	TA 200 DU	100–142	462	63	450	170M3020	170H3004	500	6.6 URD 30 D08 A 0500	36
PSS175/300	TA 200 DU	100–175	590	117	500	170M3021	170H3004	530	6.6 URD 30 D08 A 0550	65
PSS250/430	TA 450 DU	130–250	815	117	700	170M5013	170H3004	630	6.6 URD 31 D08 A 0630	65
PSS300/515	TA 450 DU	130–300	965	140	900	170M5015	170H3004	900	6.6 URD 32 D11 A 0900	65

¹⁾ For the supply circuit 6 A delayed, for MCB use C characteristics.

²⁾ Calculated power loss at operational current (I_{op}) without by-pass.

$P_{tot} = 3 \times I_{op} + VA$ value

Example: PSS 60/105 running at 52A

$P_{tot} = 3 \times 52 + 10 = 166W$

When using bypass, the powerloss is reduced to the VA value only.

Softstarters

Type PSS18/30 ... PSS300/515

UL ratings

3-phase motor rating - In Line

Softstarters	Motor power P (hp) and full load current FLA, (A)							
	U _e 200V / 208V		U _e 220V / 240V		U _e 440V / 480V		U _e 550V / 600V	
	hp	A	hp	A	hp	A	hp	A
PSS18/30	5	18	5	18	10	18	15	18
PSS30/52	7.5	28	10	28	20	28	25	28
PSS37/64	10	34	10	34	25	34	30	34
PSS44/76	10	40	10	40	30	40	30	40
PSS50/85	15	47	15	47	30	47	40	47
PSS60/105	15	56	20	56	40	56	50	56
PSS72/124	20	67	20	67	50	67	60	67
PSS85/147	25	85	30	85	60	85	75	85
PSS105/181	30	105	40	105	75	105	100	105
PSS142/245	40	125	40	125	100	125	125	125
PSS175/300	50	156	60	156	125	156	150	156
PSS250/430	75	225	75	225	150	225	200	225
PSS300/515	75	248	100	248	200	248	250	248

3-phase motor rating - Inside Delta

Softstarters	Motor power P (hp) and full load current FLA, (A)							
	U _e 200V / 208V		U _e 220V / 240V		U _e 440V / 480V		U _e 550V / 600V	
	hp	A	hp	A	hp	A	hp	A
PSS18/30	7.5	30	10	30	20	30	25	30
PSS30/52	15	48	15	48	30	48	40	48
PSS37/64	20	58	20	58	40	58	50	58
PSS44/76	20	69	25	69	50	69	60	69
PSS50/85	25	81	30	81	60	81	75	81
PSS60/105	30	96	30	96	75	96	75	96
PSS72/124	40	116	40	116	75	116	100	116
PSS85/147	50	147	50	147	100	147	150	147
PSS105/181	60	181	60	181	150	181	150	181
PSS142/245	75	215	75	215	150	215	200	215
PSS175/300	75	270	100	270	200	270	250	270
PSS250/430	125	389	150	389	300	389	400	389
PSS300/515	150	429	150	429	350	429	400	429

Softstarters

Type PST30 ... 300 and PSTB370 ... 1050
Overview



1SFC132172F0001

PST30 ... PST72



1SFC132173F0001

PST85 ... PST142

Normal start:

In Line connected

(400 V) kW
IEC, Max. A

(440-480 V) hp
UL, Max. A

Softstarter, Type

	PST30	PST37	PST44	PST50	PST60	PST72	PST85	PST105	PST142
(400 V) kW	15	18.5	22	25	30	37	45	55	75
IEC, Max. A	30	37	44	50	60	72	85	105	142
(440-480 V) hp	20	25	30	40	40	50	60	75	100
UL, Max. A	28	34	42	54	60	68	80	104	130

400V, 40 °C

MCCB (50 kA), Type

If using MCCB only, type 1 coordination will be achieved.

T2S160	T2S160	T2S160	T2S160	T2S160	T2S160	T2S160	T2S160	T3S250	T3S250
--------	--------	--------	--------	--------	--------	--------	--------	--------	--------

Fuse protection (65 kA) Semiconductor fuses, Bussmann, Type

To achieve a type 2 coordination, semi-conductor fuses must be used.

170M1366	170M1368	170M1369	170M1369	170M1370	170M1371	170M1372	170M3019	170M3020
----------	----------	----------	----------	----------	----------	----------	----------	----------

Switch fuse, Type

Suitable switch fuse for recommended semi-conductor fuses.

OS160RD0380	OS160RD0380	OS160RD0380	OS160RD0380	OS160RD0380	OS160RD0380	OS160RD0380	OESA250R03D80	OESA250R03D80
-------------	-------------	-------------	-------------	-------------	-------------	-------------	---------------	---------------

Line contactor, Type

The line contactor is not required for the softstarter itself but often used to open if OL trips.

A30	A40	A50	A50	A63	A75	A95	A110	A145
-----	-----	-----	-----	-----	-----	-----	------	------

Electronic overload relay

The overload relay is always required to protect the motor.

Built-in	Built-in	Built-in	Built-in	Built-in	Built-in	Built-in	Built-in	Built-in
----------	----------	----------	----------	----------	----------	----------	----------	----------

By-pass contactor, Type

The by-pass contactor can be used to reduce the power loss of the softstarter but also to increase the number of starts/h. All softstarters can be operated without by-pass.

A16	A26	A26	A30	A40	A50	A50	A63	A95
-----	-----	-----	-----	-----	-----	-----	-----	-----

Current transformers

Integrated	Integrated	Integrated	Integrated	Integrated	Integrated	Integrated	Integrated	Integrated
------------	------------	------------	------------	------------	------------	------------	------------	------------

The table above is an overview of possible combinations of devices.
Complete coordination tables are available at www.abb.com/lowvoltage.

Softstarters

Type PST30 ... 300 and PSTB370 ... 1050
Overview



1SFC132174F0001



1SFC132175F0001



1SFC132176F0001

PST175... PST300

PSTB370 ... 470

PSTB570 ... 1050

Softstarter, Type

PST175	PST210	PST250	PST300	PSTB370	PSTB470	PSTB570	PSTB720	PSTB840	PSTB1050
90	110	132	160	200	250	315	400	450	560
175	210	250	300	370	470	570	720	840	1050
125	150	200	250	300	400	500	600	700	900
156	192	248	302	361	480	590	720	840	1062

400V, 40 °C

MCCB (50 kA), Type

T4S250	T4S250	T5S400	T5S400	T5S630	T5S630	T6S630	T6S800	T7S1250	T7S1600
--------	--------	--------	--------	--------	--------	--------	--------	---------	---------

Fuse protection (65 kA) Semiconductor fuses, Busmann, Type

170M3021	170M5012	170M5013	170M5015	170M5013	170M5015	170M5015	170M5018	170M6018	170M6020 ²⁾
----------	----------	----------	----------	----------	----------	----------	----------	----------	------------------------

Switch fuse, Type

OESA250R03D80	OESA400R03D80	OESA400R03D80	OESA630R03D80	OESA800R03D80	¹⁾	¹⁾
	OESA400R03D80	OESA400R03D80	OESA630R03D80	OESA800R03D80		

Line contactor, Type

A185	A210	A260	A300	AF400	AF580	AF580	AF750	AF1350	AF1650
------	------	------	------	-------	-------	-------	-------	--------	--------

Electronic overload relay

Built-in	Built-in	Built-in	Built-in	Built-in	Built-in	Built-in	Built-in	Built-in	Built-in
----------	----------	----------	----------	----------	----------	----------	----------	----------	----------

By-pass contactor, Type

A145	A145	A145	A210	Built-in	Built-in	Built-in	Built-in	Built-in	Built-in
------	------	------	------	----------	----------	----------	----------	----------	----------

Current transformers

Integrated	Integrated	Integrated	Integrated	Integrated	Integrated	Integrated	Integrated	Integrated	Integrated
------------	------------	------------	------------	------------	------------	------------	------------	------------	------------

¹⁾ PSTB840 and PSTB1050: Switch fuse not available, use fuseholder, see page 40.

²⁾ PSTB1050-690-70 has 170M6019

How to select correct size

By using the guide beside, you can quickly select a suitable softstarter for the most common applications.

If a more precise selection is required, you can use Prosoft, a selection software available at www.abb.com/lowvoltage.

Quick guide for selection

Normal start Class 10

Ordering – See page 26 –27

Typical applications

- Bow thruster
- Compressor
- Elevator
- Centrifugal pump
- Conveyor belt (short)
- Escalator

Heavy duty start Class 30

Ordering – See page 28 –29

Typical applications

- Centrifugal fan
- Crusher
- Mixer
- Conveyor belt (long)
- Mill
- Stirrer

If more than 10 starts /h

! Select **one** size larger than the standard selection.

Softstarters

Type PST30 ... 300 and PSTB370 ... 1050 Application and description

Application

The PST range is a microprocessor based softstarter designed with the latest technology for soft start and soft stop of motors. The PST Softstarter has several advanced motor protection features as standard. The four button keypad and the logic structure of the menu make the installation, commissioning and operation easy. It is possible to choose between 14 different languages.

The PST Softstarter can be used with or without a by-pass contactor except for the larger sizes PSTB370 ... PSTB1050 where the by-pass contactor is already built-in.

The PST Softstarter can be selected according to the rated motor power in **normal duty** applications like pumps, compressors, elevators, escalators, short conveyor belts and bow thrusters. See page 26-27

For **heavy duty** applications like centrifugal fans, crushers, mixers, mills, stirrers and long conveyor belts, select a softstarter from page 28-29.

Description

- Wide main voltage range 208 - 690 V AC
- Wide supply voltage range 100 – 250 V, 50/60 Hz
- Current ratings 30 to 1050 A (In Line) and 52 ... 1810 A (Inside Delta)
- Same unit can be used for both In Line and Inside Delta connection
- Premium adjustable Softstarter functions like start/stop ramp, kick start, jog, step down voltage and sequential starts.
- Current limit adjustable between $2-7 \times I_e$
- Thermistor (PTC) supervision of motor winding
- Real time clock
- Logging of last 20 events with time marking
- Prepared for fieldbus communication
- Motor overload protection with simulated motor temperature from measured current. Select between 10A, 10, 20 and 30
- Locked rotor protection
- Motor underload protection
- Phase imbalance protection
- Phase reversal protection
- Torque control
- Analog output

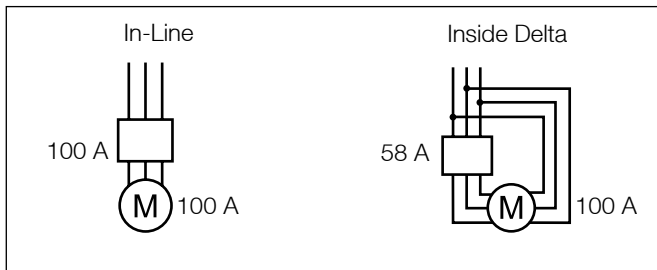

In-Line and Inside Delta connection of PST30 ... PSTB1050

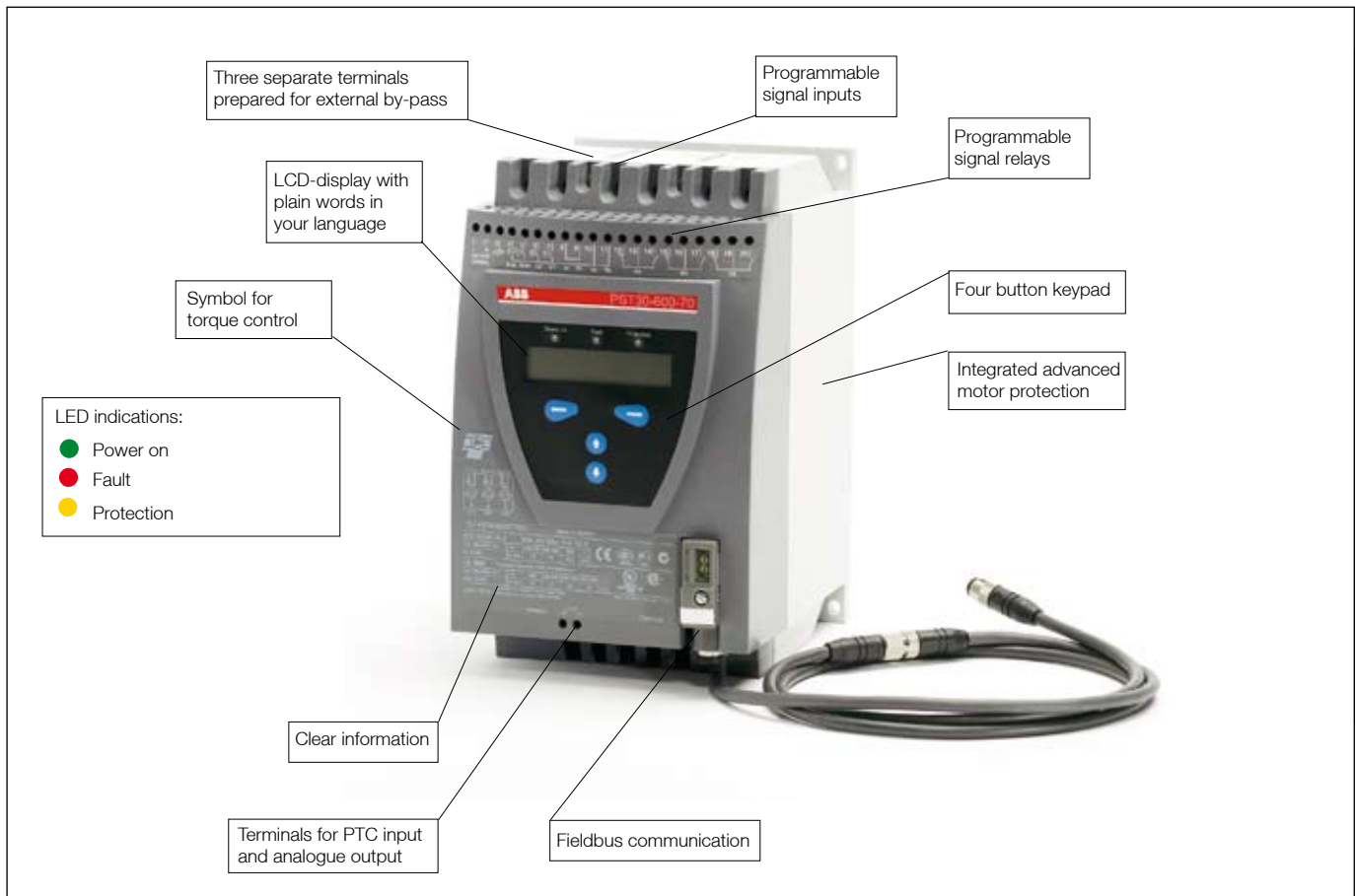

Softstarters

Type PST30 ... 300 and PSTB370 ... 1050

Functional description

HMI (Human Machine Interface)

The display of the PST gives you information presented in plain words in required language. You can choose between 14 different languages, on the display you get all the information you need to set up, adjust and trouble-shoot.

The PST employs the same basic user concept as today's advanced mobile telephones. Using the four buttons on the keypad, you can easily adjust your own start and stop profile and motor protection functions for any type of application. There are standard settings for many common applications including pumps, conveyors, fans, mixers and compressors for quick and easy set up.

All of this makes the PST extremely easy to handle.

Starting several motors

You can store as many as three different starting parameter sets for optimal sequence start of three different motors. You can use this function for two or three speed motors as well.

Integrated advanced motor protection

Inside the PST Softstarter, you will find useful features for advanced motor and softstarter protection, including; programmable overload protection, high current, underload, phase imbalance, phase reversal, thyristor overload protection, and bypass monitoring to ensure proper by-pass operation.

Coated PCBs

The PST(B) softstarter can be ordered as a version with coated PCBs. This coating can extend the lifelength of the PSBs in for instance waste water plants where corrosive acids and gases may exist.

Programmable signal relays

All PST units have three programmable signal relays where each relay can signal Run, Top of Ramp or Event. The Event setting can be used to signal protections, faults and warnings. The supervisory functions monitor not only software and critical softstarter functionality but also phase loss and out of frequency range.

Integrated by-pass contactor

On the larger sizes (PSTB 370 ... PSTB1050), there is an ABB AF contactor integrated. This gives you advantages in terms of cost-saving, space saving and last but not least energy saving. With a by-pass contactor you can reduce the power losses during normal run by 90 % or more.

The smaller units, PST30 up to PST300, which are not equipped with a built-in by-pass contactor, have an extra set of three terminals on the line side. The terminals are marked B1, B2 and B3 and shall be used when connecting an external by-pass contactor. This will enable the integrated protection functions also when the softstarter is by-passed.

External keypad (option)

An external keypad is available as option. The keypad can be mounted on a panel door for example to view/control the softstarter without opening the door. The keypad can also be used to copy parameters between different softstarters.



Fieldbus communication

The PST Softstarter has a built-in interface on the front for connection of the ABB FieldBusPlug used for fieldbus communication. Through this interface it is possible to control the softstarter, achieve status information, up- and down load of parameters. The interface between the softstarter and the FieldBusPlug is always the same. Independently of PST Softstarter size or delivery date it is possible to connect to any fieldbus protocol later on since this is defined in the FieldBusPlug itself. Available protocols are DeviceNet, Profibus DP, Modbus-RTU and CANopen. To connect the PST Softstarter to a fieldbus system you need the accessories described on page 31 to 34 as well as specific software for PLC set-up, which is available at www.abb.com/lowvoltage on the Softstarter pages.

Torque control

The default setting is a normal voltage ramp but it is possible to select torque ramp. With the torque control function it is possible to start and stop motors with a more linear acceleration than when using the normal voltage ramps.



During start this can be used to reduce the wear on the equipment driven by the motor.

During stop, controlling the torque is especially useful for pump applications where voltage ramps can lead to a sudden torque drop which may result in water hammering and pressure surges. Torque control will keep these problems to an absolute minimum.

Torque limit

With the torque limit function enabled, the torque can never exceed a set value during start. This will minimize stress and wear on the equipment driven by the motor.

Analog output

With the PST(B) softstarter it is possible to have analog output signals to be used as input to a PLC or an analog meter. The output signals can be selected to be for instance the current of the motor, main voltage, active power or the temperature of the motor. The terminals used for analog output are also used for PTC protection, so only one of these functions can be used.



PSTB570 with integrated by-pass contactor.

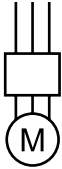

Softstarters

Type PST30 ... 300 and PSTB370 ... 1050
Normal starts, class 10 – In-Line, Ordering details



PST30 ... PST72



PST85 ... PST142



PST175 ... PST300



PSTB370 ... PSTB470



PSTB570 ... PSTB1050

1SFC132172F0001

1SFC132173F0001

1SFC132174F0001

1SFC132175F0001

1SFC132176F0001

PST30 ... PST300

230 – 600 V

Supply voltage, U_s , 100...250 V, 50/60 Hz

Motor power

400 V P_o kW	500 V P_o kW	690 V P_o kW	Rated motor current, I_o A	Type ¹⁾	Order code ²⁾	Weight kg
15	18,5	-	30	PST30-600-70□	1SFA 894 002 R70▽0	4.8
18,5	22	-	37	PST37-600-70□	1SFA 894 003 R70▽0	4.8
22	25	-	44	PST44-600-70□	1SFA 894 004 R70▽0	4.8
25	30	-	50	PST50-600-70□	1SFA 894 005 R70▽0	4.8
30	37	-	60	PST60-600-70□	1SFA 894 006 R70▽0	5.0
37	45	-	72	PST72-600-70□	1SFA 894 007 R70▽0	5.0
45	55	-	85	PST85-600-70□	1SFA 894 008 R70▽0	11.2
55	75	-	105	PST105-600-70□	1SFA 894 009 R70▽0	13.0
75	90	-	142	PST142-600-70□	1SFA 894 010 R70▽0	13.0
90	110	-	175	PST175-600-70□	1SFA 894 011 R70▽0	21.5
110	132	-	210	PST210-600-70□	1SFA 894 012 R70▽0	21.5
132	160	-	250	PST250-600-70□	1SFA 894 013 R70▽0	23.0
160	200	-	300	PST300-600-70□	1SFA 894 014 R70▽0	23.0

400 – 690 V

Supply voltage, U_s , 100...250 V, 50/60 Hz

Motor power

400 V P_o kW	500 V P_o kW	690 V P_o kW	Rated motor current, I_o A	Type ¹⁾	Order code ²⁾	Weight kg
15	18,5	25	30	PST30-690-70□	1SFA 895 002 R70▽0	4.8
18,5	22	30	37	PST37-690-70□	1SFA 895 003 R70▽0	4.8
22	25	37	44	PST44-690-70□	1SFA 895 004 R70▽0	4.8
25	30	45	50	PST50-690-70□	1SFA 895 005 R70▽0	4.8
30	37	55	60	PST60-690-70□	1SFA 895 006 R70▽0	5.0
37	45	59	72	PST72-690-70□	1SFA 895 007 R70▽0	5.0
45	55	75	85	PST85-690-70□	1SFA 895 008 R70▽0	11.2
55	75	90	105	PST105-690-70□	1SFA 895 009 R70▽0	13.0
75	90	132	142	PST142-690-70□	1SFA 895 010 R70▽0	13.0
90	110	160	175	PST175-690-70□	1SFA 895 011 R70▽0	21.5
110	132	184	210	PST210-690-70□	1SFA 895 012 R70▽0	21.5
132	160	220	250	PST250-690-70□	1SFA 895 013 R70▽0	23.0
160	200	257	300	PST300-690-70□	1SFA 895 014 R70▽0	23.0

PSTB370 ... PSTB1050 with integrated by-pass

230 – 600 V

Supply voltage, U_s , 100...250 V, 50/60 Hz

Motor power

400 V P_o kW	500 V P_o kW	690 V P_o kW	Rated motor current, I_o A	Type ¹⁾	Order code ²⁾	Weight kg
200	257	-	370	PSTB370-600-70□	1SFA 894 015 R70▽0	31.0
250	315	-	470	PSTB470-600-70□	1SFA 894 016 R70▽0	31.0
315	400	-	570	PSTB570-600-70□	1SFA 894 017 R70▽0	52.0
400	500	-	720	PSTB720-600-70□	1SFA 894 018 R70▽0	55.0
450	600	-	840	PSTB840-600-70□	1SFA 894 019 R70▽0	60.0
560	730	-	1050	PSTB1050-600-70□	1SFA 894 020 R70▽0	60.0

400 – 690 V

Supply voltage, U_s , 100...250 V, 50/60 Hz

Motor power

400 V P_o kW	500 V P_o kW	690 V P_o kW	Rated motor current, I_o A	Type ¹⁾	Order code ²⁾	Weight kg
200	257	355	370	PSTB370-690-70□	1SFA 895 015 R70▽0	31.0
250	315	450	470	PSTB470-690-70□	1SFA 895 016 R70▽0	31.0
315	400	560	570	PSTB570-690-70□	1SFA 895 017 R70▽0	52.0
400	500	710	720	PSTB720-690-70□	1SFA 895 018 R70▽0	55.0
450	600	800	840	PSTB840-690-70□	1SFA 895 019 R70▽0	60.0
560	730	1000	1050	PSTB1050-690-70□	1SFA 895 020 R70▽0	60.0

¹⁾ Add code letter in Type acc. to below:
□ No code letter = Normal
T = Coated PCBs

²⁾ Add code number in Order code acc. to below:
▽ 0 = Normal
2 = Coated PCBs

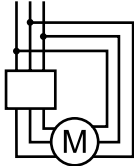

Softstarters

Type PST30 ... 300 and PSTB370 ... 1050

Normal starts, class 10 – Inside Delta, Ordering details



PST30 ... PST72



PST85 ... PST142



PST175 ... PST300



PSTB370 ... PSTB470



PSTB570 ... PSTB1050

1SFC132172FD001

1SFC132173FD001

1SFC132174FD001

1SFC132175FD001

1SFC132176FD001

PST30 ... PST300

230 – 600 V

Supply voltage, U_s , 100...250 V, 50/60 Hz

Motor power

400 V P_o kW	500 V P_o kW	690 V P_o kW	Rated motor current, I_o A	Type ¹⁾	Order code ²⁾	Weight kg
25	30	-	52	PST30-600-70□	1SFA 894 002 R70▽0	4.8
30	37	-	64	PST37-600-70□	1SFA 894 003 R70▽0	4.8
37	45	-	76	PST44-600-70□	1SFA 894 004 R70▽0	4.8
45	55	-	85	PST50-600-70□	1SFA 894 005 R70▽0	4.8
55	75	-	105	PST60-600-70□	1SFA 894 006 R70▽0	5.0
59	80	-	124	PST72-600-70□	1SFA 894 007 R70▽0	5.0
75	90	-	147	PST85-600-70□	1SFA 894 008 R70▽0	11.2
90	110	-	181	PST105-600-70□	1SFA 894 009 R70▽0	13.0
132	160	-	245	PST142-600-70□	1SFA 894 010 R70▽0	13.0
160	200	-	300	PST175-600-70□	1SFA 894 011 R70▽0	21.5
184	250	-	360	PST210-600-70□	1SFA 894 012 R70▽0	21.5
220	295	-	430	PST250-600-70□	1SFA 894 013 R70▽0	23.0
257	355	-	515	PST300-600-70□	1SFA 894 014 R70▽0	23.0

400 – 690 V

Supply voltage, U_s , 100...250 V, 50/60 Hz

Motor power

400 V P_o kW	500 V P_o kW	690 V P_o kW	Rated motor current, I_o A	Type ¹⁾	Order code ²⁾	Weight kg
25	30	45	52	PST30-690-70□	1SFA 895 002 R70▽0	4.8
30	37	55	64	PST37-690-70□	1SFA 895 003 R70▽0	4.8
37	45	59	76	PST44-690-70□	1SFA 895 004 R70▽0	4.8
45	55	75	85	PST50-690-70□	1SFA 895 005 R70▽0	4.8
55	75	90	105	PST60-690-70□	1SFA 895 006 R70▽0	5.0
59	80	110	124	PST72-690-70□	1SFA 895 007 R70▽0	5.0
75	90	132	147	PST85-690-70□	1SFA 895 008 R70▽0	11.2
90	110	160	181	PST105-690-70□	1SFA 895 009 R70▽0	13.0
132	160	220	245	PST142-690-70□	1SFA 895 010 R70▽0	13.0
160	200	257	300	PST175-690-70□	1SFA 895 011 R70▽0	21.5
184	250	315	360	PST210-690-70□	1SFA 895 012 R70▽0	21.5
220	295	400	430	PST250-690-70□	1SFA 895 013 R70▽0	23.0
257	355	500	515	PST300-690-70□	1SFA 895 014 R70▽0	23.0

PSTB370...PSTB1050 with integrated by-pass

230 – 600 V

Supply voltage, U_s , 100...250 V, 50/60 Hz

Motor power

400 V P_o kW	500 V P_o kW	690 V P_o kW	Rated motor current, I_o A	Type ¹⁾	Order code ²⁾	Weight kg
355	450	-	640	PSTB370-600-70□	1SFA 894 015 R70▽0	31.0
450	600	-	814	PSTB470-600-70□	1SFA 894 016 R70▽0	31.0
540	700	-	987	PSTB570-600-70□	1SFA 894 017 R70▽0	52.0
710	880	-	1247	PSTB720-600-70□	1SFA 894 018 R70▽0	55.0
800	1000	-	1455	PSTB840-600-70□	1SFA 894 019 R70▽0	60.0
1000	1250	-	1810	PSTB1050-600-70□	1SFA 894 020 R70▽0	60.0

400 – 690 V

Supply voltage, U_s , 100...250 V, 50/60 Hz

Motor power

400 V P_o kW	500 V P_o kW	690 V P_o kW	Rated motor current, I_o A	Type ¹⁾	Order code ²⁾	Weight kg
355	450	600	640	PSTB370-690-70□	1SFA 895 015 R70▽0	31.0
450	600	800	814	PSTB470-690-70□	1SFA 895 016 R70▽0	31.0
540	700	960	987	PSTB570-690-70□	1SFA 895 017 R70▽0	52.0
710	880	1200	1247	PSTB720-690-70□	1SFA 895 018 R70▽0	55.0
800	1000	1400	1455	PSTB840-690-70□	1SFA 895 019 R70▽0	60.0
1000	1250	1700	1810	PSTB1050-690-70□	1SFA 895 020 R70▽0	60.0

¹⁾ Add code letter in Type acc. to below:

- No code letter = Normal
- T = Coated PCBs

²⁾ Add code number in Order code acc. to below:

- ▽ 0 = Normal
- 2 = Coated PCBs

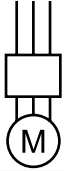

Softstarters

Type PST37 ... 300 and PSTB370 ... 1050

Heavy duty starts, class 30 – In-Line, Ordering details



PST30 ... PST72

1SFC132172F0001



PST85 ... PST142

1SFC132173F0001



PST175 ... PST300

1SFC132174F0001



PSTB370 ... PSTB470

1SFC132175F0001



PSTB570...PSTB1050

1SFC132176F0001

PST37 ... PST300

230 – 600 V

Supply voltage, U_s , 100...250 V, 50/60 Hz

Motor power

400 V P_o kW	500 V P_o kW	690 V P_o kW	Rated motor current, I_o A	Type ^{*)}	Order code ^{**)}	Weight kg
15	18,5	-	30	PST37-600-70	1SFA 894 003 R70	4,8
18,5	22	-	37	PST44-600-70	1SFA 894 004 R70	4,8
22	25	-	44	PST50-600-70	1SFA 894 005 R70	4,8
25	30	-	50	PST60-600-70	1SFA 894 006 R70	5,0
30	37	-	60	PST72-600-70	1SFA 894 007 R70	5,0
37	45	-	72	PST85-600-70	1SFA 894 008 R70	11,2
45	55	-	85	PST105-600-70	1SFA 894 009 R70	13,0
55	75	-	105	PST142-600-70	1SFA 894 010 R70	13,0
75	90	-	142	PST175-600-70	1SFA 894 011 R70	21,5
90	110	-	175	PST210-600-70	1SFA 894 012 R70	21,5
110	132	-	210	PST250-600-70	1SFA 894 013 R70	23,0
132	160	-	250	PST300-600-70	1SFA 894 014 R70	23,0

400 – 690 V

Supply voltage, U_s , 100...250 V, 50/60 Hz

Motor power

400 V P_o kW	500 V P_o kW	690 V P_o kW	Rated motor current, I_o A	Type ^{*)}	Order code ^{**)}	Weight kg
15	18,5	25	30	PST37-690-70	1SFA 895 003 R70	4,8
18,5	22	30	37	PST44-690-70	1SFA 895 004 R70	4,8
22	25	37	44	PST50-690-70	1SFA 895 005 R70	4,8
25	30	45	50	PST60-690-70	1SFA 895 006 R70	5,0
30	37	55	60	PST72-690-70	1SFA 895 007 R70	5,0
37	45	59	72	PST85-690-70	1SFA 895 008 R70	11,2
45	55	75	85	PST105-690-70	1SFA 895 009 R70	13,0
55	75	90	105	PST142-690-70	1SFA 895 010 R70	13,0
75	90	132	142	PST175-690-70	1SFA 895 011 R70	21,5
90	110	160	175	PST210-690-70	1SFA 895 012 R70	21,5
110	132	184	210	PST250-690-70	1SFA 895 013 R70	23,0
132	160	220	250	PST300-690-70	1SFA 895 014 R70	23,0

PSTB370 ... PSTB1050 with integrated by-pass

230 – 600 V

Supply voltage, U_s , 100...250 V, 50/60 Hz

Motor power

400 V P_o kW	500 V P_o kW	690 V P_o kW	Rated motor current, I_o A	Type ^{*)}	Order code ^{**)}	Weight kg
160	200	-	300	PSTB370-600-70	1SFA 894 015 R70	31,0
200	257	-	370	PSTB470-600-70	1SFA 894 016 R70	31,0
250	315	-	470	PSTB570-600-70	1SFA 894 017 R70	52,0
315	400	-	570	PSTB720-600-70	1SFA 894 018 R70	55,0
400	500	-	720	PSTB840-600-70	1SFA 894 019 R70	60,0
450	600	-	840	PSTB1050-600-70	1SFA 894 020 R70	60,0

400 – 690 V

Supply voltage, U_s , 100...250 V, 50/60 Hz

Motor power

400 V P_o kW	500 V P_o kW	690 V P_o kW	Rated motor current, I_o A	Type ^{*)}	Order code ^{**)}	Weight kg
160	200	257	300	PSTB370-690-70	1SFA 895 015 R70	31,0
200	257	355	370	PSTB470-690-70	1SFA 895 016 R70	31,0
250	315	450	470	PSTB570-690-70	1SFA 895 017 R70	52,0
315	400	560	570	PSTB720-690-70	1SFA 895 018 R70	55,0
400	500	710	720	PSTB840-690-70	1SFA 895 019 R70	60,0
450	600	800	840	PSTB1050-690-70	1SFA 895 020 R70	60,0

^{*)} Add code letter in Type acc. to below:
 No code letter = Normal
 T = Coated PCBs

<sup>**) Add code number in Order code acc. to below:
 0 = Normal
 2 = Coated PCBs</sup>

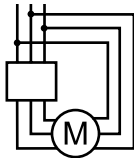

Softstarters

Type PST37 ... 300 and PSTB370 ... 1050

Heavy duty starts, class 30 – Inside Delta, Ordering details



PST30 ... PST72

1SFC132172F0001



PST85 ... PST142

1SFC132173F0001



PST175 ... PST300

1SFC132174F0001



PSTB370 ... PSTB470

1SFC132175F0001



PSTB570 ... PSTB1050

1SFC132176F0001

PST37 ... PST300

230 – 600 V

Supply voltage, U_s 100...250 V, 50/60 Hz

Motor power

400 V P_o kW	500 V P_o kW	690 V P_o kW	Rated motor current, I_o A	Type ^{*)}	Order code ^{**)}	Weight kg
25	30	-	52	PST37-600-70□	1SFA 894 003 R70▽0	4.8
30	37	-	64	PST44-600-70□	1SFA 894 004 R70▽0	4.8
37	45	-	76	PST50-600-70□	1SFA 894 005 R70▽0	4.8
45	55	-	85	PST60-600-70□	1SFA 894 006 R70▽0	5.0
55	75	-	105	PST72-600-70□	1SFA 894 007 R70▽0	5.0
59	80	-	124	PST85-600-70□	1SFA 894 008 R70▽0	11.2
75	90	-	147	PST105-600-70□	1SFA 894 009 R70▽0	13.0
90	110	-	181	PST142-600-70□	1SFA 894 010 R70▽0	13.0
132	160	-	245	PST175-600-70□	1SFA 894 011 R70▽0	21.5
160	200	-	300	PST210-600-70□	1SFA 894 012 R70▽0	21.5
184	250	-	360	PST250-600-70□	1SFA 894 013 R70▽0	23.0
220	295	-	430	PST300-600-70□	1SFA 894 014 R70▽0	23.0

400 – 690 V

Supply voltage, U_s 100...250 V, 50/60 Hz

Motor power

400 V P_o kW	500 V P_o kW	690 V P_o kW	Rated motor current, I_o A	Type ^{*)}	Order code ^{**)}	Weight kg
25	30	45	52	PST37-690-70□	1SFA 895 003 R70▽0	4.8
30	37	55	64	PST44-690-70□	1SFA 895 004 R70▽0	4.8
37	45	59	76	PST50-690-70□	1SFA 895 005 R70▽0	4.8
45	55	75	90	PST60-690-70□	1SFA 895 006 R70▽0	5.0
55	75	90	105	PST72-690-70□	1SFA 895 007 R70▽0	5.0
59	80	110	124	PST85-690-70□	1SFA 895 008 R70▽0	11.2
75	90	132	147	PST105-690-70□	1SFA 895 009 R70▽0	13.0
90	110	160	181	PST142-690-70□	1SFA 895 010 R70▽0	13.0
132	160	220	245	PST175-690-70□	1SFA 895 011 R70▽0	21.5
160	200	257	300	PST210-690-70□	1SFA 895 012 R70▽0	21.5
184	250	315	360	PST250-690-70□	1SFA 895 013 R70▽0	23.0
220	295	400	430	PST300-690-70□	1SFA 895 014 R70▽0	23.0

PSTB370...PSTB1050 with integrated by-pass

230 – 600 V

Supply voltage, U_s 100...250 V, 50/60 Hz

Motor power

400 V P_o kW	500 V P_o kW	690 V P_o kW	Rated motor current, I_o A	Type ^{*)}	Order code ^{**)}	Weight kg,
257	355	-	515	PSTB370-600-70□	1SFA 894 015 R70▽0	31.0
355	450	-	640	PSTB470-600-70□	1SFA 894 016 R70▽0	31.0
450	600	-	814	PSTB570-600-70□	1SFA 894 017 R70▽0	52.0
540	700	-	987	PSTB720-600-70□	1SFA 894 018 R70▽0	55.0
710	880	-	1247	PSTB840-600-70□	1SFA 894 019 R70▽0	60.0
800	1000	-	1455	PSTB1050-600-70□	1SFA 894 020 R70▽0	60.0

400 – 690 V

Supply voltage, U_s 100...250 V, 50/60 Hz

Motor power

400 V P_o kW	500 V P_o kW	690 V P_o kW	Rated motor current, I_o A	Type ^{*)}	Order code ^{**)}	Weight kg
257	355	500	515	PSTB370-690-70□	1SFA 895 015 R70▽0	31.0
355	450	600	640	PSTB470-690-70□	1SFA 895 016 R70▽0	31.0
450	600	800	814	PSTB570-690-70□	1SFA 895 017 R70▽0	52.0
540	700	960	987	PSTB720-690-70□	1SFA 895 018 R70▽0	55.0
710	880	1200	1247	PSTB840-690-70□	1SFA 895 019 R70▽0	60.0
800	1000	1400	1455	PSTB1050-690-70□	1SFA 895 020 R70▽0	60.0

^{*)} Add code letter in Type acc. to below:
□ No code letter = Normal
T = Coated PCBs

^{**)} Add code number in Order code acc. to below:
▽ 0 = Normal
2 = Coated PCBs

Softstarters

Accessories for type PST30 ... 300 and PSTB370 ... 1050

Ordering details

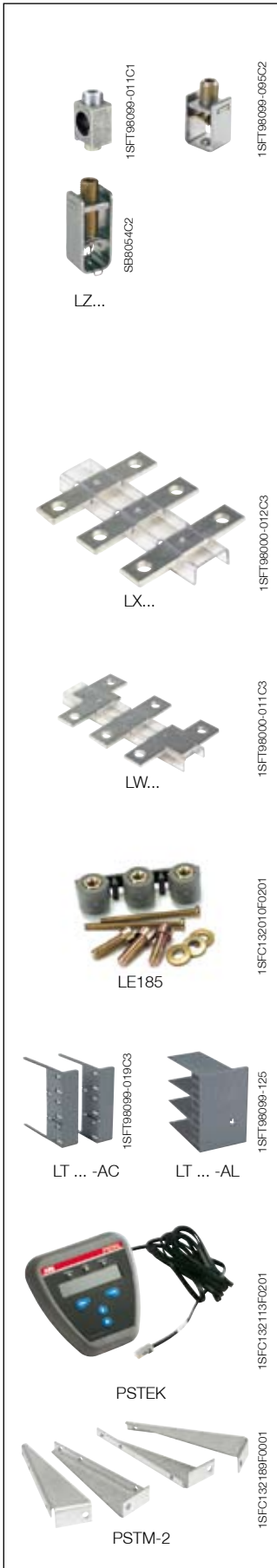

Cable connectors for Cu cables

For PST85...300 you need 9 pieces if also using the terminals B1, B2, B3 for external by-pass contactor.

For softstarter type	Wire range mm ²	Tightening torque max. Nm	Type	Order code	Pack ^{ing} piece	Weight kg
PST85 ...142	6-185	16	-	1SDA 023 354 R0001	3	0.20
PST85 ...142	2 x (50-120)	16	LZ185-2C/120	1SFN 074 709 R1000	3	0.30
PST175 ...PSTB470	16-240	25	-	1SDA 023 368 R0001	3	0.40

Cable connectors for Al and Cu cables

For PST85...300 you need 9 pieces if also using the terminals B1, B2, B3 for external by-pass contactor.

For softstarter type	Wire range mm ²	Tightening torque max. Nm	Type	Order code	Pack ^{ing} piece	Weight kg
PST85 ...142	35-95	13.5	-	1SDA 023 356 R0001	3	0.10
PST85 ...142	25-150	31	-	1SDA 023 357 R0001	3	0.10
PST175 ...300	120-240	43	-	1SDA 023 370 R0001	3	0.10
PSTB370 ...1050	3 x (70-185)	43	-	1SDA 023 384 R0001	3	0.265
PSTB370 ...1050	2 x (120-240)	31	-	1SDA 023 380 R0001	3	0.110

Terminal extensions

For softstarter type	Dimensions hole ø mm ²	bar mm	Type	Order code	Pack ^{ing} pieces	Weight kg
PST85...142 ¹⁾	8.5	17.5 x 5	LX185	1SFN 074 710 R1000	1	0.250
PST175...300 ²⁾	10.5	20 x 5	LX300	1SFN 075 110 R1000	1	0.350
PSTB370...470	10.5	25 x 5	LX460	1SFN 075 710 R1000	1	0.500
PSTB570...1050	13	40 x 6	LX750	1SFN 076 110 R1000	1	0.850

Terminal enlargements

For softstarter type	Dimensions hole ø mm ²	bar mm	Type	Order code	Pack ^{ing} pieces	Weight kg
PST30...72 ¹⁾	6.5	15 x 3	LW110	1SFN 074 307 R1000	1	0.100
PST85...142 ¹⁾	10.5	17.5 x 5	LW185	1SFN 074 707 R1000	1	0.250
PST175...300	10.5	20 x 5	LW300	1SFN 075 107 R1000	1	0.450
PSTB370...470	10.5	25 x 5	LW460	1SFN 075 707 R1000	1	0.730
PSTB570...1050	13	40 x 6	LW750	1SFN 076 107 R1000	1	1.230

Terminal nut washer

For softstarter type	Type	Order code	Pack ^{ing} piece	Weight kg
PST85...142 ¹⁾	LE185	1SFN 074 716 R1000	2	0.20
PST175...300 ²⁾	LE300	1SFN 075 116 R1000	2	0.30

Terminal shrouds

For softstarter type	Req. qty	Type	Order code	Pack ^{ing} pieces	Weight kg
PST85...142	1 pcs and	LT185-AC	1SFN 124 701 R1000	2	0.050
	1 pcs	LT460-AC	1SFN 125 701 R1000	2	0.100
PST85...142	1 pcs and	LT185-AL	1SFN 124 703 R1000	2	0.220
	1 pcs	LT460-AL	1SFN 125 703 R1000	2	0.800
PST175...300 ²⁾	3 pcs	LT300-AC	1SFN 125 101 R1000	2	0.070
PST175...300 ²⁾	3 pcs	LT300-AL	1SFN 125 103 R1000	2	0.280
PSTB370...470	2 pcs	LT460-AC	1SFN 125 701 R1000	2	0.100
PSTB370...470	2 pcs	LT460-AL	1SFN 125 703 R1000	2	0.800
PSTB570...1050	2 pcs	LT750-AC	1SFN 126 101 R1000	2	0.120
PSTB570...1050	2 pcs	LT750-AL	1SFN 126 103 R1000	2	0.825

External keypad including a 3m cable

For softstarter type	Type	Order code	Pack ^{ing} piece	Weight kg
PST30...300 PSTB370...1050	PSTEK	1SFA 899 003 R1000	1	0.400

Marine Kit

For softstarter type	Type	Order code	Pack ^{ing} piece	Weight kg
PST85...142	PSTM-2	1SFA 899 004 R1000	1	0.24

¹⁾ Only fits on the motor side

²⁾ Use two sets of the accessories on the line side and one set on the motor side.



Softstarters

FBP FieldBusPlug

DeviceNet, MODBUS-RTU and CANopen fieldbus connectors

Black cable

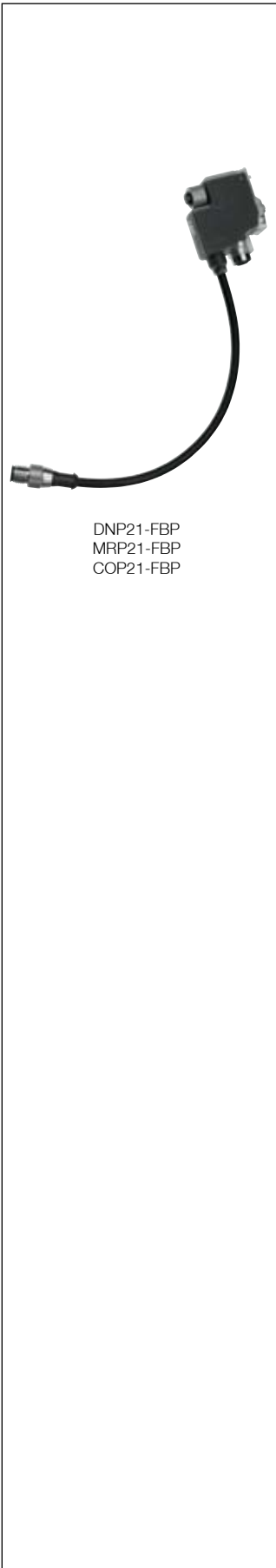

DNP21-FBP
MRP21-FBP
COP21-FBP

DeviceNet FieldBusPlug

Ready-made DeviceNet fieldbus interface with various cable lengths.

- Applicable on all FBP motor starters and other devices
- Degree of protection IP65, diagnostic LED

Designation	Cable length	Type	Order code	Pack ^{ing} pieces	Weight kg 1 piece
DeviceNet-FBP	0.25 m	DNP21-FBP.025	1SAJ 230 000 R1003	1	0.09
DeviceNet-FBP	0.50 m	DNP21-FBP.050	1SAJ 230 000 R1005	1	0.10
DeviceNet-FBP	1.00 m	DNP21-FBP.100	1SAJ 230 000 R1010	1	0.13

MODBUS-RTU FieldBusPlug

Ready-made MODBUS-RTU fieldbus interface with various cable lengths.

- Applicable on all FBP motor starters and other devices
- Degree of protection IP65, diagnostic LED

Designation	Cable length	Type	Order code	Pack ^{ing} pieces	Weight kg 1 piece
MODBUS-RTU-FBP	0.25 m	MRP21-FBP.025	1SAJ 250 000 R0003	1	0.09
MODBUS-RTU-FBP	0.50 m	MRP21-FBP.050	1SAJ 250 000 R0005	1	0.10
MODBUS-RTU-FBP	1.00 m	MRP21-FBP.100	1SAJ 250 000 R0010	1	0.13

CANopen FieldBusPlug

Ready-made CANopen fieldbus interface with various cable lengths.

- Applicable on all FBP motor starters and other devices
- Degree of protection IP65, diagnostic LED

Designation	Cable length	Type	Order code	Pack ^{ing} pieces	Weight kg 1 piece
CANopen-FBP	0.25 m	COP21-FBP.025	1SAJ 230 100 R1003	1	0.09
CANopen-FBP	0.50 m	COP21-FBP.050	1SAJ 230 100 R1005	1	0.10
CANopen-FBP	1.00 m	COP21-FBP.100	1SAJ 230 100 R1010	1	0.13

To connect the PST Softstarter to a DeviceNet fieldbus system...

you need specific software for PLC set-up, (EDS file) which is available at www.abb.com/lowvoltage on the Softstarter pages. Look under the documentation-link named Software. If you need help or advice, please contact your local ABB office.



Softstarters

FBP FieldBusPlug

DeviceNet, MODBUS-RTU and CANopen fieldbus accessories

Black cable

Accessories for the DeviceNet, MODBUS-RTU and CANopen Bus Connector

DeviceNet, MODBUS-RTU and CANopen Round Cable for Bus Junctions

Ready-made bus cable with an M12 connector and an open cable end.

Designation	Cable length	Type	Order code	Pack ^{ing} pieces	Weight kg 1 piece
Round Cable with female connector	0.50 m	DNF11-FBP.050	1SAJ 923 002 R0005	1	0.04
Round Cable with male connector	0.50 m	DNM11-FBP.050	1SAJ 923 003 R0005	1	0.04

DeviceNet, MODBUS-RTU and CANopen Round Cable for Bus Extension

Ready-made bus cable with M12 male and female connectors

Designation	Cable length	Type	Order code	Pack ^{ing} pieces	Weight kg 1 piece
Extension Cable	1.00 m	DNX11-FBP.100	1SAJ 923 001 R0010	1	0.08
Extension Cable	3.00 m	DNX11-FBP.300	1SAJ 923 001 R0030	1	0.20
Extension Cable	5.00 m	DNX11-FBP.500	1SAJ 923 001 R0050	1	0.31
Round Cable	100 m	DNC11-FBP.999	1SAJ 923 004 R0001	1	5.6

DeviceNet, MODBUS-RTU and CANopen Round Cable and Accessories for Bus Extension Bus cable and coupling accessories

Designation	Cable length	Type	Order code	Pack ^{ing} pieces	Weight kg 1 piece
Round Cable Male Connector		DNM11-FBP.0	1SAJ 923 005 R0001	5	0.15
Device Net Round Cable Female Connector		DNF11-FBP.0	1SAJ 923 006 R0001	5	0.15

DeviceNet, MODBUS-RTU and CANopen Termination Resistor, Miscellaneous Accessories

Designation	Type	Order code	Pack ^{ing} pieces	Weight kg 1 piece
Termination Resistor, 120 Ohm	DNR11-FBP.120	1SAJ 923 007 R0001	1	0.02



To connect the PST Softstarter to a DeviceNet fieldbus system...

you need specific software for PLC set-up, (EDS file) which is available at www.abb.com/lowvoltage on the Softstarter pages. Look under the documentation-link named Software. If you need help or advice, please contact your local ABB office.



Softstarters

FBP FieldBusPlug

Profibus DP/V0 and DP/V1 fieldbus connectors



PDP22-FBP



PDQ22-FBP

2000-341 048 F0008

Profibus DP/V0 and DP/V1 FieldBusPlug

Ready-made Profibus DP/V1 fieldbus interface with various cable lengths.

- Applicable on all FBP motor starters and other devices
- Degree of protection IP65, diagnostic LED

Designation	Cable length	Type	Order code	Pack ^{ing} pieces	Weight kg 1 piece
Profibus DP/V1-FBP	0.25 m	PDP22-FBP.025	1SAJ 240 100 R1003	1	0.09
Profibus DP/V1-FBP	0.50 m	PDP22-FBP.050	1SAJ 240 100 R1005	1	0.10
Profibus DP/V1-FBP	1.00 m	PDP22-FBP.100	1SAJ 240 100 R1010	1	0.13
Profibus DP/V1-FBP	2.00 m	PDP22-FBP.200	1SAJ 240 100 R1020	1	0.20
Profibus DP/V1-FBP	5.00 m	PDP22-FBP.500	1SAJ 240 100 R1050	1	0.36

PDP21 is replaced by PDP22.

4 x Profibus DP/V0 and DP/V1 FieldBusPlug

PDQ22 is a member of the ABB FieldBusPlug family of bus connectors. It allows the connection of up to four devices to Profibus DP by just using one Profibus node access. This allows a cost efficient device integration for devices that are located physically nearby. PDQ22 supports DP-V0 and DP-V1. The degree of protection is IP66. There are separate diagnosis LEDs for bus and device status.

Note that the accessories PDQ22-FBP only works with the PSR and not with the PST(B) softstarter.

Designation	Type	Order code	Pack ^{ing} pieces	Weight kg 1 piece
-	PDQ22-FBP	1SAJ 240 200 R0050	1	0.20

DINrail adapter for Profibus FieldBusPlug PDQ22-FBP

Designation	Type	Order code	Pack ^{ing} pieces	Weight kg 1 piece
DINrail adapter for PDQ22-FBP	CDA11-FBP. 0	1SAJ 929 300 R0001	1	0.11

Extension cable

Designation	Cable length	Type	Order code	Pack ^{ing} pieces	Weight kg 1 piece
Extension cable (female/male), shielded	1.5 m	CDP15-FBP.150	1SAJ 929 140 R0015	1	0.20
Extension cable (male/open), shielded	1.5 m	CDP16-FBP.150	1SAJ 929 150 R0015	1	0.20

To connect the PST Softstarter to a Profibus DP fieldbus system...

you need specific software for PLC set-up, (GSD file) which is available at www.abb.com/lowvoltage on the Softstarter pages. Look under the documentation-link named Software. If you need help or advice, please contact your local ABB office.

PDP21 is replaced by PDP22.

Use PDP22 with the GSD-file Abb_082d.gsd regardless if the PLC is a DP/V0 or DP/V1.



Softstarters

FBP FieldBusPlug

Profibus DP/V0, DP/V1 fieldbus accessories



Accessories for the Profibus DP/V0 and DP/V1 Bus Connector

Profibus DP/V0 and DP/V1 Round Cable for Bus Junctions

Ready-made bus cable with an M12 connector and an open cable end.

- Application on bus junctions such as e.g. Profibus DB couplers or devices with an integrated Profibus DB interface

Designation	Cable length	Type	Order code	Pack ^{ing} pieces	Weight kg 1 piece
Round Cable with female connector	0.50 m	PDF11-FBP.050	1SAJ 924 002 R0005	1	0.04
Round Cable with male connector	0.50 m	PDM11-FBP.050	1SAJ 924 003 R0005	1	0.04

Profibus DP/V0, DP/V1 Round Cable for Bus Extension

Ready-made bus cable with M12 male and female connectors

Designation	Cable length	Type	Order code	Pack ^{ing} pieces	Weight kg 1 piece
Extension Cable	1.00 m	PDX11-FBP.100	1SAJ 924 001 R0010	1	0.08
Extension Cable	3.00 m	PDX11-FBP.300	1SAJ 924 001 R0030	1	0.20
Extension Cable	5.00 m	PDX11-FBP.500	1SAJ 924 001 R0050	1	0.31
Round Cable	100 m	PDC11-FBP.999	1SAJ 924 004 R1000	1	5.60

Profibus DP/V0, DP/V1 Accessories for Bus Extension

Designation	Type	Order code	Pack ^{ing} pieces	Weight kg 1 piece
Male Connector	PDM11-FBP.0	1SAJ 924 005 R0001	5	0.03
Female Connector	PDF11-FBP.0	1SAJ 924 006 R0001	5	0.03

Profibus DP/V0, DP/V1 Termination Resistor, Miscellaneous Accessories

Designation	Type	Order code	Pack ^{ing} pieces	Weight kg 1 piece
Termination resistor, 150 ohm	PDR11-FBP.150	1SAJ 924 007 R0001	1	0.03
Feeding connector 24V DC Code B-A	PDV11-FBP.0	1SAJ 924 008 R0001	1	0.04
Feeding connector 24V DC Code A-A	PDV12-FBP.0	1SAJ 924 011 R0001	1	0.04
Adaptor M12-Dsub9-M12 Cable lenth 0.50m	PDA11-FBP.050	1SAJ 924 009 R0001	1	0.04
Adaptor M12-Dsub9-M12 Cable lenth 2 x 0.50m	PDA12-FBP.050	1SAJ 924 010 R0001	1	0.04

To connect the PST Softstarter to a Profibus DP fieldbus system...

you need specific software for PLC set-up, (GSD file) which is available at www.abb.com/lowvoltage on the Softstarter pages. Look under the documentation-link named Software. If you need help or advice, please contact your local ABB office.

Softstarters

Type PST(B)30 ... 1050

Technical data

	PST(B)30 ... 1050	
Rated insulation voltage U_i	690 V	
Rated operational voltage U_e	208 ... 690 V +10 %/-15 %	
Starting capacity at max rated current I_r	3 x I_r for 15 sec.	
Number of starts per hour	PST30 ... 300 30 ¹⁾	PSTB370 ... 1050 10 ¹⁾
Overload capability , Overload Class	10	
Service factor	PST(B)30...840 115 %	PSTB1050 100 %
Ambient temperature During operation During storage	±0 ... +50 °C ²⁾ -25... +70 °C	
Altitude Maximum altitude	4000 m ³⁾	
Degree of protection Main circuit Supply and Control circuit	PST30 ... 72 IP10 IP20	PST85 ... PSTB1050 IP00
Main circuit Built in By-pass contactor Cooling system - Fan cooled (thermostat controlled)	PST30 ... 300 No Yes	PSTB370 ... 1050 Yes
Supply circuit Supply voltage U_s - one range	100 ... 250 V +10 %/-15 %, 50/60 Hz ±5 %	
HMI for settings (Human Machine Interface) 20 segment display Keypad with two selection keys and two navigating keys Plain text in 14 languages (English, German, Italian, Dutch, Chinese, Finnish, Swedish, French, Spanish, Russian, Portuguese, Turkish, Polish and Czech)	Yes Yes Yes Yes	
Signal relays Number of programmable signal relays (Each relay can be programmed to be Run, By-pass or Event signal) K4 - Default as Run signal K5 - Default as By-pass signal K6 - Default as Event signal Rated operational voltage U_e Rated thermal current I_{th} Rated operational current I_e at AC-15 ($U_e = 250$ V)	3 Yes Yes Yes 250 V 5 A 1.5 A	
Analogue output Output signal reference Type of output signal	0 ... 10 V, 0 ... 20 mA, 4 ... 20 mA I Amp, U Volt, P kW, P hp, Q kVAR, S kVA, TmpMot, TmpSCR, cosPhi	

PST(B)30 ... 1050

Control circuit /Hardware inputs Internal 24 V DC (10 mA closed) Start / Stop inputs Two extra programmable inputs (Each input can be programmed to be either; Non, Reset, Enable, Jog, DOL- On, Start motor 2 or Start motor 3, FB-Dis).	Yes Yes Yes
---	-------------------

Signal indication LED's Power on - Green Fault - Red Protection - Yellow	Yes Yes Yes
--	-------------------

Protections Electronic overload Adjustable tripping classes - Class 10 A, 10, 20 and 30 Dual overload (separate overload function for start and run) PTC connection Locked rotor protection Underload protection Phase imbalance High current (8 x I_r) Phase reversal protection	Yes Yes Yes Yes Yes Yes Yes Yes
---	--

Warnings (pre-warning) High current Low current (underload) Overload trip Overtemp. thyristors (SCR)	Yes Yes Yes Yes
---	--------------------------

Start of several motors Possible to set up and start three different motors	Yes
---	-----

Field bus connection Connection for ABB FieldBusPlug	Yes
--	-----

PTC input Switch off resistance Switch on resistance	2825 ohm ± 20% 1200 ohm ± 20%
---	----------------------------------

External keypad Display Ambient temperature During operation During storage Degree of protection	LCD type ± 0...+50 °C -25...+70 °C IP66
--	--

¹⁾ Valid for 50 % on time and 50 % off time, with 3.5 x I_e for 7 seconds. If other data is required, please contact your sales office

²⁾ Above 40 °C up to max. 50 °C reduce the rated current with 0.8 % per °C.

³⁾ When used at high altitudes above 1000 meters up to 4000 meters you need to derate rated current using the following formula.

$$[\% \text{ of } I_e = 100 - \frac{x - 1000}{150}]$$

x = actual altitude for the softstarter

PSTB Integrated by-pass ratings

Softstarter	Type	PSTB370	PSTB470	PSTB570	PSTB720	PSTB840	PSTB1050
Contactors	Type	AF300	AF300	AF460	AF580	AF750	AF750
AC-3 rating	A	305	305	460	580	750	750

Softstarters

Type PST30 ... 300 and PSTB370 ... 1050

Technical data/Settings

Major possible settings and the displayed text and the set default values

Description	Text on display (Eng)	Values on display	Default value
Setting current for overload, locked rotor etc.	Setting I_e	9,0 ... 1207 A divided into 19 overlapping ranges.	See table, page 40
Time for start ramp	Start Ramp	1 ... 30 s, 1 ... 120 s (Range depends on Start Range)	10 s
Time for stop ramp	Stop Ramp	0 ... 30 s, 0 ... 120 s (Range depends on Stop Range)	0 s
Initial voltage for start ramp	Init Volt	30 ... 70 %	30 %
End voltage for stop ramp	End Volt	30 ... 70 %	30 %
Step down voltage	Step Down	30 ... 100 %	100 %
Level of the current limit.	Current Lim	1.5 ... 7.0 x I_e	4.0 x I_e
Selection of Kick start	Kick Start	Yes, No	No
Level of Kick start if selected	Kick Level	50 ... 100 %	50 %
Time for Kick start if selected	Kick Time	0.1 ... 1.5 s	0.2
Selectable range for start ramp	Start Range	1 ... 30 s, 1...120 s	1 ... 30 s
Selectable range for stop ramp	Stop Range	0 ... 30 s, 0 ... 120 s	0 ... 30 s
Overload protection	Overload	No, Normal, Dual	Normal
Overload Class	OL Class	10 A, 10, 20, 30	10
Overload Class, Dual type, Start Class	OL Class S	10A, 10, 20, 30	10
Overload Class, Dual type, Run Class	OL Class R	10A, 10, 20, 30	10
Type of operation for overload protection	OL Op	Stop-M, Stop-A, Ind	Stop-M
Locked rotor protection	Locked Rotor	Yes, No	No
Trip level for locked rotor protection	Lock R Lev	0.5 ... 8.0 x I_e	4,0 x I_e
Trip time for locked rotor protection	Lock R Time	0.2 ... 10 s	1.0 s
Type of operation for locked rotor protection	Lock R Op	Stop-M, Stop-A, Ind	Stop-M
Underload protection	Underload	Yes, No	No
Trip level for Underload protection	Underl Lev	0.4 ... 0.8 x I_e	0.5 x I_e
Trip time for Underload protection	Underl Time	1 ... 30 s	10 s
Type of operation for Underload protection	Underl Op	Stop-M, Stop-A, Ind	Stop-M
Phase imbalance protection	Phase Imb	Yes, No	No
Trip level for phase imbalance protection	Ph Imb Lev	10 ... 80 %	80 %
Type of operation for phase imbalance protection	Ph Imb Op	Stop-M, Stop-A, Ind	Stop-M
High current protection	High I	Yes, No	No
Type of operation for high current protection	High I Op	Stop-M, Stop-A, Ind	Stop-M
Phase reversal protection	Phase Rev	Yes, No	No
Type of operation for phase reversal protection	Ph Rev Op	Stop-M, Stop-A, Ind	Stop-M
PTC protection	PTC	Yes, No	No
Type of operation for PTC protection	PTC Op	Stop-M, Stop-A	Stop-M
An external Bypass contactor is used	Ext ByPass	Yes, No	No
High current warning	Warn I=High	Yes, No	No
Trip level for high current warning	Wa I=H Lev	0.5 ... 5.0 x I_e	1.2 x I_e
Low current warning	Warn I=Low	Yes, No	No
Trip level for low current warning	Wa I=L Lev	0.4 ... 1.0 x I_e	0.8 x I_e
Overload warning	Warn OL	Yes, No	No
Trip level for overload warning	Wa OL Lev	40 ... 99 %	90 %
Thyristor overload warning	Warn SCR OL	Yes, No	No
Type of operation for phase loss fault	Ph Loss Op	Stop-M, Stop-A	Stop-M
Type of operation for by-pass doesn't close	BP open Op	Stop-M, Stop-A	Stop-M
Type of operation for by-pass doesn't open	BP closed Op	Stop-M, Stop-A	Stop-M
Type of operation for fieldbus fault	FB Fault Op	Stop-M, Stop-A	Stop-M
Type of operation for frequency fault	Freq F Op	Stop-M, Stop-A	Stop-M
Type of operation for heat sink over temperature fault	HS Temp Op	Stop-M, Stop-A	Stop-M
Type of operation for thyristor short circuit fault	SCR SC Op	Stop-M, Stop-A	Stop-M
Function of programmable input In_0	In0	None, Reset, Enable, Jog, DOL, Start 2, FB-Dis	Reset
Function of programmable input In_1	In1	None, Reset, Enable, Jog, DOL, Start 3, FB-Dis	Reset
Function of programmable relay output K4	Relay K4	Run, TOR, Event	Run
Function of programmable relay output K5	Relay K5	Run, TOR, Event	TOR
Function of programmable relay output K6	Relay K6	Run, TOR, Event	Event
Control of the softstarter with fieldbus	Fieldb Ctrl	Yes, No	No
Number of sequences for sequence start.	No of Seq	No, 2, 3	No
Language to use on display	Language	US/UK, FI, SE, PT, NL, IT, FR, ES, DE, CN, RU, TR, PL, CZ	US/UK
Password for display	Password	No, 1 ... 255	
Start mode	Start Mode	Volt, Torque	Volt
Stop mode	Stop Mode	Volt, Torque	Volt
Torque limit	Torque limit	20 ... 200 %	150 %
Analog output	Analogue Out	Yes, No	No
Analog output, reference	Anl Ref	0 ... 10 V, 0 ... 20 mA, 4 ... 20 mA	4 ... 20 mA
Analog output, type of value	Anl Type	I Amp, U Volt, P kW, P hp, Q kVAr, S kVA, TmpMot, TmpSCR, cosPhi	I Amp

Softstarters

Type PST30 ... 300 and PSTB370 ... 1050
 Technical data/Settings

Tripping curves for the integrated electronic overload protection

All units have an integrated electronic overload protection possible to set on four different tripping classes. Below you find a curve for each tripping class in cold state.



ABB FieldBusPlug

Controlling possibilities when using different field buses

	AS-Interface	DeviceNet	Profibus DP V0	Profibus DP V1	Modbus-RTU	CANopen
Simple control (start/stop etc)	X	X	X	X	X	X
Complete control	-	X	X	X	X	X
Simple status information	X	X	X	X	X	X
Detailed status information	-	X	X	X	X	X
Possibilities to write parameters	-	X	X	X	X	X
Possibilities to read parameters	-	X	-	X	-	X

For more detailed information, please see separate Installation and Commissioning manuals available at www.abb.com/lowvoltage on the Softstarter pages.

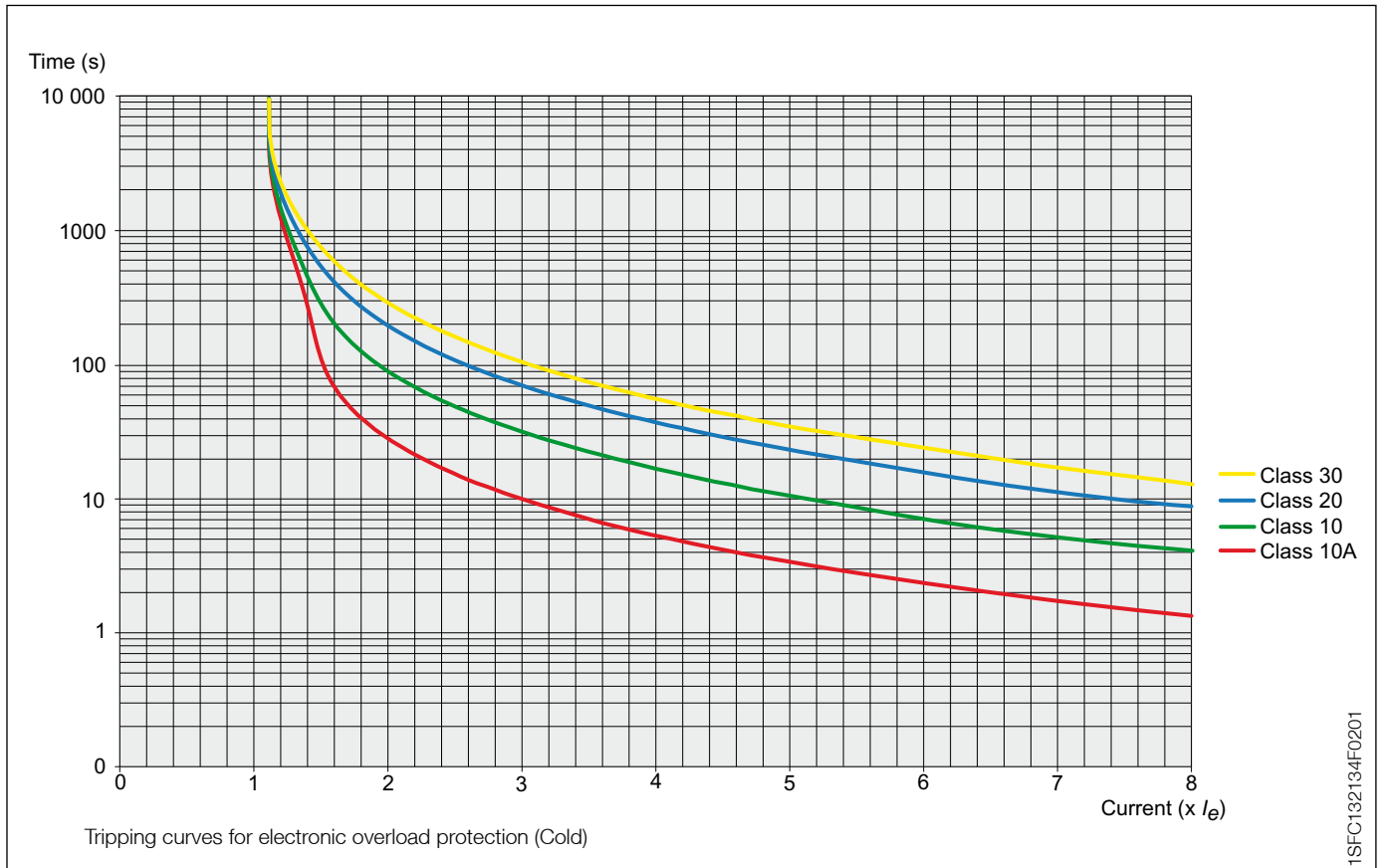
Softstarters

Type PST30 ... 300 and PSTB370 ... 1050

Technical data/Settings

Cross section of connectable cables

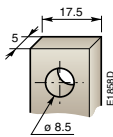
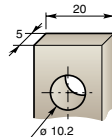
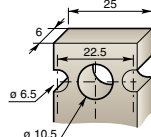
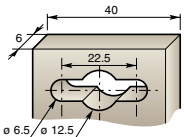
		Type of softstarter				
		PST30 ... 72	PST85 ... 142	PST175 ... 300	PSTB370 ... 470	PSTB570 ... 1050
Main circuit						
Available terminals:	L1, L2, L3	Yes	Yes	Yes	Yes	Yes
	T1, T2, T3	Yes	Yes	Yes	Yes	Yes
(For external by-pass):	B1, B2, B3	Yes	Yes	Yes	No	No
Connection clamp						
						
Solid/Stranded	1 x mm ²	10 ... 95	See accessories	See accessories	–	–
Solid/Stranded	2 x mm ²	6 ... 35	See accessories	See accessories	–	–
Tightening torque (recommended), Nm		6.0	See accessories	See accessories	–	–
Connection bar						
		No				
Width and thickness	mm	–				
Hole diameter	mm	–	ø 8.5	ø 10.2	ø 10.5	ø 6.5 / ø 12.5
Tightening torque (recommended), Nm		–	9	18	40	49
Supply and control circuit						
Connection clamp		Yes	Yes	Yes	Yes	Yes
Solid/Stranded	1 x mm ²	2.5	2.5	2.5	2.5	2.5
Solid/Stranded	2 x mm ²	1.5	1.5	1.5	1.5	1.5
Tightening torque (recommended), Nm		0.5	0.5	0.5	0.5	0.5

Fuse ratings and power losses

For softstarter	Recommended ABB Overload protection		Max power loss at rated I _n		Maximum fuse ratings - main circuit ¹⁾			Power requirement supply circuit		
	Type	Current range	without by-pass ²⁾	with by-pass	Bussmann fuses		Ferraz fuses		VA/VA pull in	
					A	Type	Holder	A		Type
PST										
PST30	Integrated	9...35	100	9.5	80	170M1366	170H1007	100	6,6 URB 000 D08V 0100	5
PST37	Integrated	11...43	120	10.5	125	170M1368	170H1007	160	6,6 URB 000 D08V 0160	5
PST44	Integrated	13...51	140	13.5	160	170M1369	170H1007	200	6,6 URD 30 D08A 0200	5
PST50	Integrated	15...58	160	13.5	160	170M1369	170H1007	200	6,6 URD 30 D08A 0200	5
PST60	Integrated	18...69	190	15.5	200	170M1370	170H1007	250	6,6 URD 30 D08A 0250	5
PST72	Integrated	22...83	230	17	250	170M1371	170H1007	315	6,6 URD 30 D08A 0315	5
PST85	Integrated	25...98	270	30.5	315	170M1372	170H1007	400	6,6 URD 30 D08A 0400	10
PST105	Integrated	32...120	325	35	400	170M3019	170H3004	400	6,6 URD 30 D08A 0400	10
PST142	Integrated	43...163	435	37	450	170M3020	170H3004	500	6,6 URD 30 D08A 0500	10
PST175	Integrated	53...201	540	62	500	170M3021	170H3004	550	6,6 URD 30 D08A 0550	15
PST210	Integrated	63...241	645	67	630	170M5012	170H3004	630	6,6 URD 31 D08A 0630	15
PST250	Integrated	75...288	765	67	700	170M5013	170H3004	630	6,6 URD 31 D08A 0630	15
PST300	Integrated	90...345	920	90	900	170M5015	170H3004	900	6,6 URD 32 D11A 0900	15
PSTB 600 V										
PSTB370	Integrated	111...425	N/A	90	700	170M5013	170H3004	630	6,6 URD 31 D08A 0630	20/480
PSTB470	Integrated	141...540	N/A	110	900	170M5015	170H3004	900	6,6 URD 32 D11A 0900	20/480
PSTB570	Integrated	171...655	N/A	105	900	170M5015	170H3004	900	6,6 URD 32 D11A 0900	25/900
PSTB720	Integrated	216...828	N/A	110	1250	170M5018	170H3004	1250	6,6 URD 33 D11A 1250	25/860
PSTB840	Integrated	252...966	N/A	170	1500	170M6018	170H3004	1600	6,6 URD 33 D11A 1250	25/860
PSTB1050	Integrated	315...1207	N/A	170	1800	170M6020	170H3004	2000	6,6 URD 33 PLAF 2000	25/860
PSTB 690 V										
PSTB370	Integrated	111...425	N/A	90	700	170M5013	170H3004	630	6,6 URD 31 D08A 0630	20/480
PSTB470	Integrated	141...540	N/A	110	900	170M5015	170H3004	900	6,6 URD 31 D11A 0900	20/480
PSTB570	Integrated	171...655	N/A	105	900	170M5015	170H3004	900	6,6 URD 31 D11A 0900	25/900
PSTB720	Integrated	216...828	N/A	110	1250	170M5018	170H3004	1250	6,6 URD 33 D11A 1250	25/860
PSTB840	Integrated	252...966	N/A	170	1500	170M6018	170H3004	1600	6,6 URD 33 TTFA 1600	25/860
PSTB1050	Integrated	315...1207	N/A	170	1600	170M6019	170H3004	1600	6,6 URD 33 TTFA 1600	25/860

¹⁾ For the supply circuit 6A delayed, for MCB use C characteristics.

²⁾ See PSS page 20

Softstarters

Type PST30...300, PSTB370...1050

UL ratings

3-phase motor rating - In Line

Softstarters	Motor power, P (hp), and full load current FLA, (A)							
	U _e 200V / 208V		U _e 220V / 240V		U _e 440V / 480V		U _e 550V / 600V	
	hp	A	hp	A	hp	A	hp	A
PST30	7.5	28	10	28	20	28	25	28
PST37	10	34	10	34	25	34	30	34
PST44	10	42	15	42	30	42	40	42
PST50	15	54	20	54	40	54	50	54
PST60	20	60	20	60	40	60	50	60
PST72	20	68	25	68	50	68	60	68
PST85	25	80	30	80	60	80	75	80
PST105	30	104	40	104	75	104	100	104
PST142	40	130	50	130	100	130	125	130
PST175	50	156	60	156	125	156	150	156
PST210	60	192	75	192	150	192	200	192
PST250	75	248	100	248	200	248	250	248
PST300	100	302	100	302	250	302	300	302
PSTB370	125	361	150	361	300	361	350	361
PSTB470	150	480	200	480	400	480	500	480
PSTB570	200	590	250	590	500	590	600	590
PSTB720	250	720	300	720	600	720	700	720
PSTB840	300	840	350	840	700	840	800	840
PSTB1050	400	1062	450	1062	900	1062	1000	1062

3-phase motor rating - Inside Delta

Softstarters	Motor power, P (hp), and full load current FLA, (A)							
	U _e 200V / 208V		U _e 220V / 240V		U _e 440V / 480V		U _e 550V / 600V	
	hp	A	hp	A	hp	A	hp	A
PST30	10	42	15	42	30	42	40	42
PST37	15	54	20	54	40	54	50	54
PST44	20	72	25	72	50	72	60	72
PST50	25	80	30	80	60	80	75	80
PST60	30	104	40	104	75	104	100	104
PST72	30	104	40	104	75	104	100	104
PST85	40	130	50	130	100	130	125	130
PST105	50	156	60	156	125	156	150	156
PST142	60	192	75	192	150	192	200	192
PST175	75	248	100	248	200	248	250	248
PST210	100	302	100	302	250	302	300	302
PST250	125	361	150	361	300	361	350	361
PST300	150	480	200	480	400	480	500	480
PSTB370	200	590	250	590	500	590	600	590
PSTB470	250	720	300	720	600	720	700	720
PSTB570	300	840	350	840	700	840	800	840
PSTB720	400	1247	500	1247	1000	1247	1200	1247
PSTB840	500	1454	600	1454	1200	1454	1500	1454
PSTB1050	600	1839	700	1839	1500	1839	1800	1839

Softstarters

Type PSR, PSS, PST and PSTB

Wall mounting instruction, dimensions

Minimum distance to wall/front

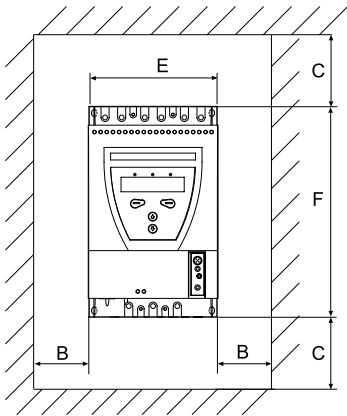
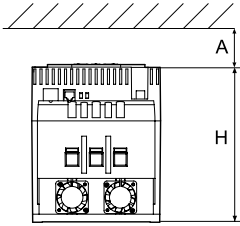

Softstarter, type	Dimensions					
	A	B	C	E	F	H
PSR3 ... PSR105						
PSR3 ... 16	25	0*	0	45	140	114
PSR25 ... 30	25	0*	0	45	160	128
PSR37 ... 45	25	0*	0	54	187	153
PSR60 ... 105	25	0*	0	70	220	180
PSS ... -500 for 500 V						
PSS18/30 ... 44/76	20	10	100	120	200	162
PSS50/85 ... 72/124	20	10	100	140	250	162
PSS85/147 ... 142/245	20	10	100	181	340	265
PSS175/300 ... 300/515	20	10	100	356	340	265
PSS ... -690 for 690 V						
PSS18/30 ... 72/124	20	10	100	140	250	163
PSS85/147 ... 142/245	20	10	100	181	340	265
PSS175/300 ... 300/515	20	10	100	356	340	265
PST - all						
PST30 ... 72	20	10	100	160	260	196
PST85 ... 142	20	10	100	186	390	270
PST175 ... 300	20	10	100	360	420	270
PSTB - all						
PSTB370 ... 470	20	15	150	365	460	361
PSTB570 ... 1050	20	15	150	435	515	381

*) 5 mm for the 24 V DC version

Dimensions PSTEK

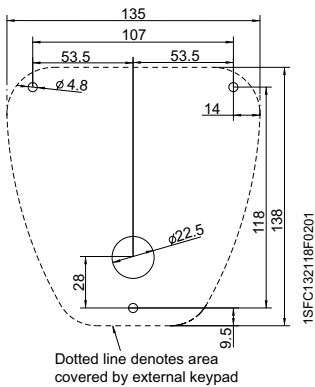
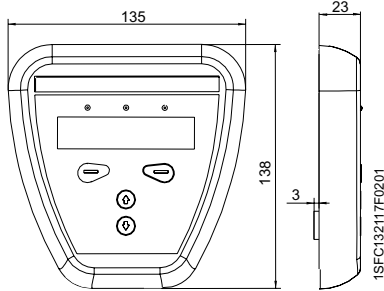

Dimensions in mm

Softstarters

Type PSR3 ... PSR105

Dimensions

PSR3 ... 16

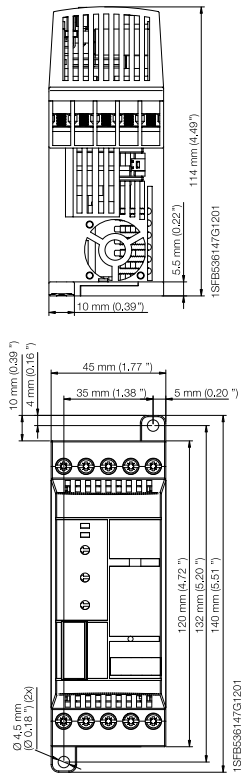

PSR37 ... 45

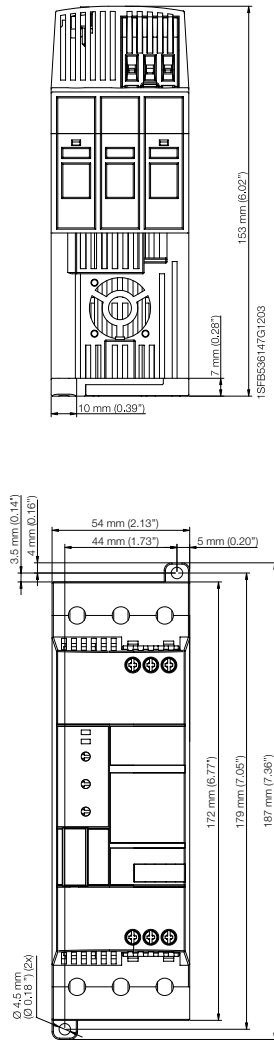

PSR60 ... 105

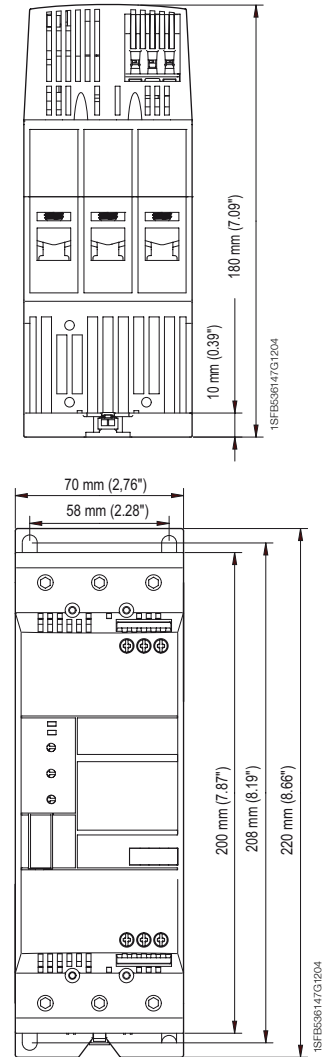

PSR25 ... 30

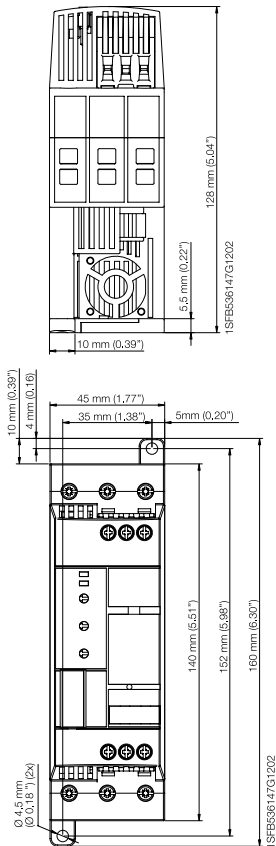

Dimensions in mm (and inches)

Softstarters

Type PSS18/30 ... PSS300/515

Dimensions

PSS18/30-500 ... 44/76-500

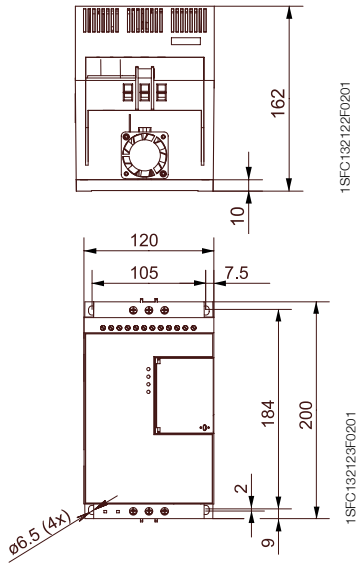

PSS50/85-500 ... 72/124-500 PSS18/30-690 ... 72/124-690

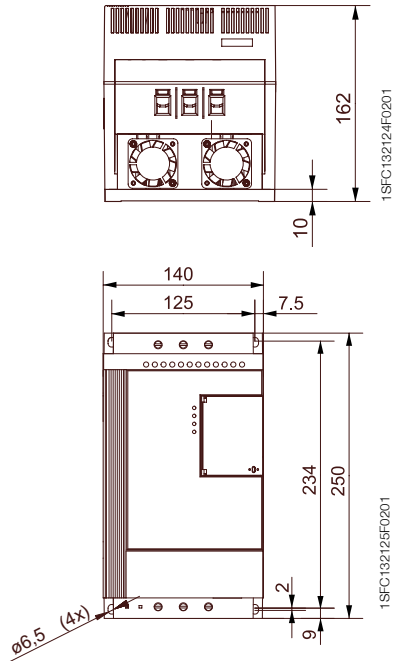

PSS85/147-500 ... 142/245-500 PSS85/147-690 ... 142/245-690

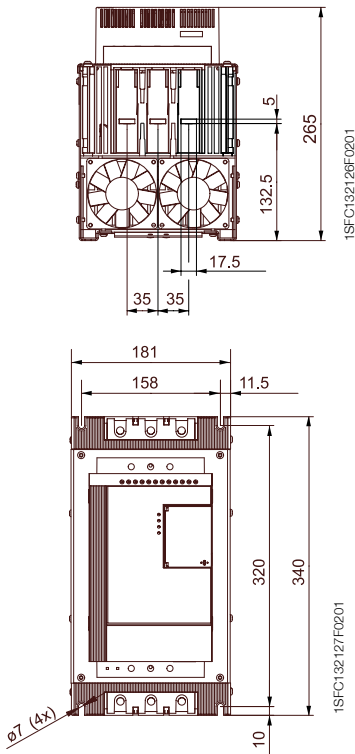

PSS 175/300-500 ... 300/515-500 PSS 175/300-690 ... 300/515-690

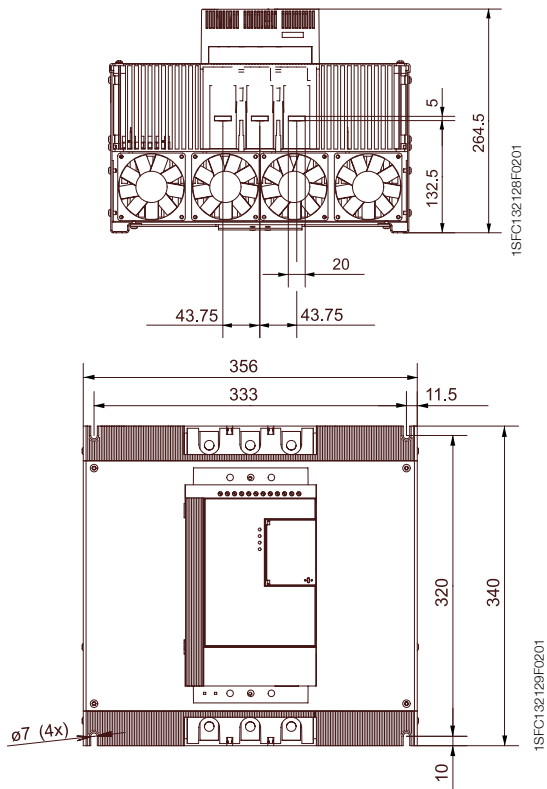

Dimensions in mm

Softstarters

Type PST30 ... 300 and PSTB370 ... 1050

Dimensions

PST30 ... 72

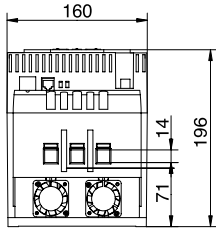

PST85 ...142

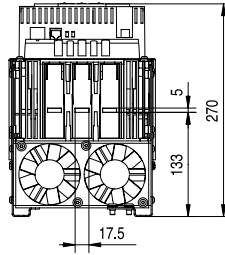

PST85 ...142 with marine kit

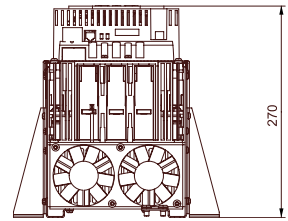

1SFC132130F0201

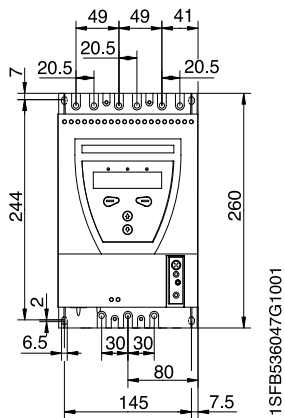

1SFB536047G1001

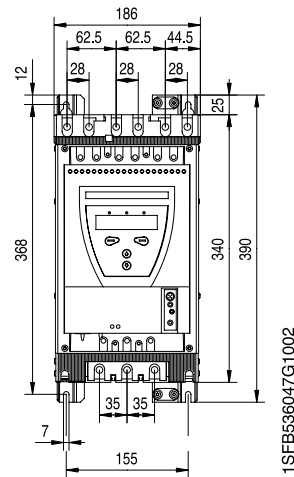

1SFB536047G1002

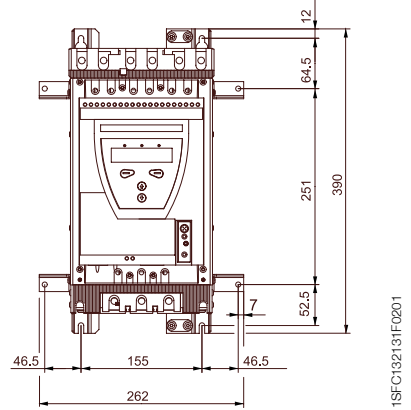

1SFC132131F0201

PST175 ... 300

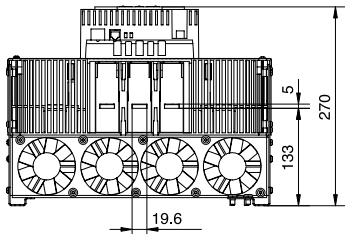

PSTB370 ... 470

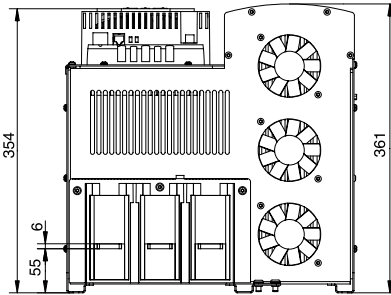

PSTB570 ... 1050

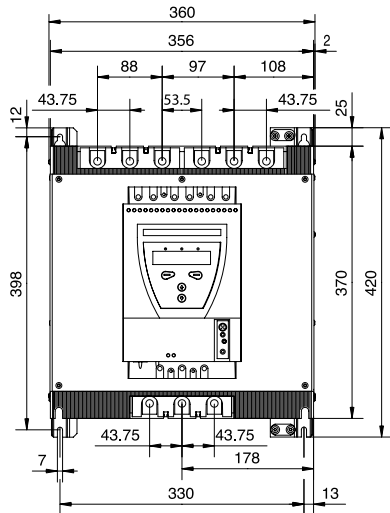
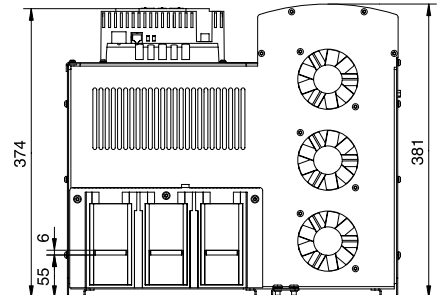

1SFB536047G1003

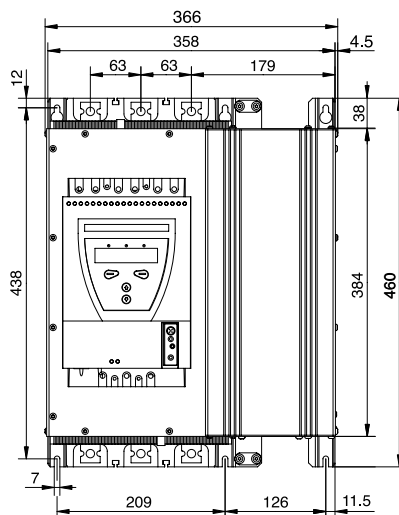

1SFB536047G1004

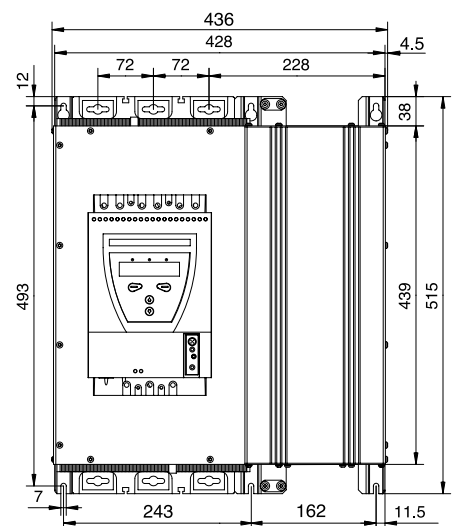

1SFB536047G1005

Dimensions in mm



Softstarters

Type PSR3 ... PSR105

Diagrams

PSR3 ... 16
A) With MMS

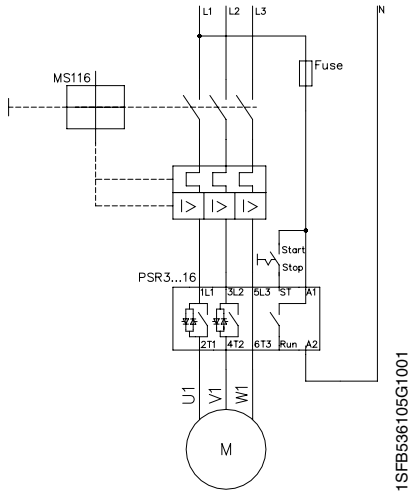

B) With MMS and auxiliary contact

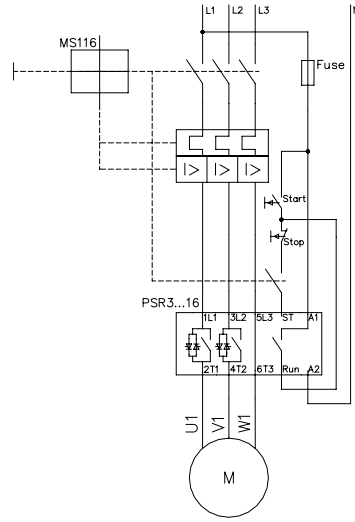

C) With fuses, contactor and O.L.

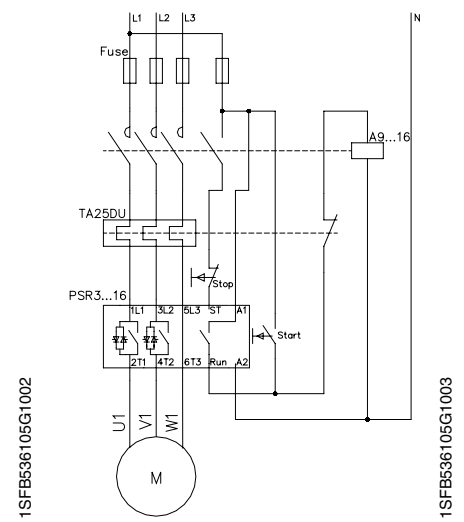

PSR25 ... 45
D) With MMS

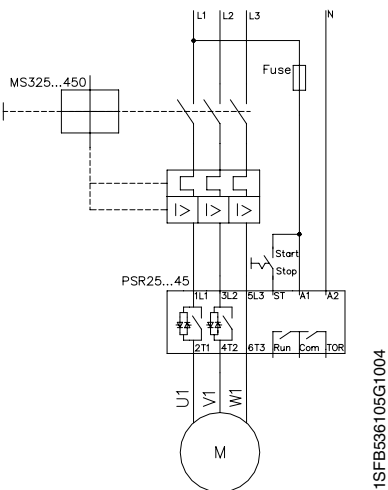

E) With MMS and auxiliary contact

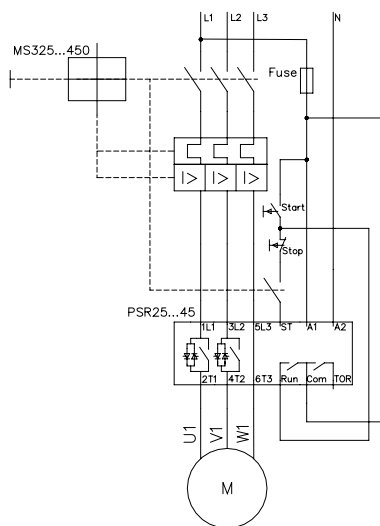

F) With fuses, contactor and O.L.

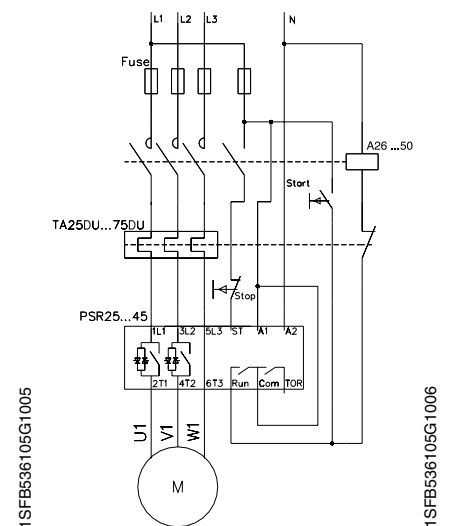

PSR60 ... 105
G) With MMS

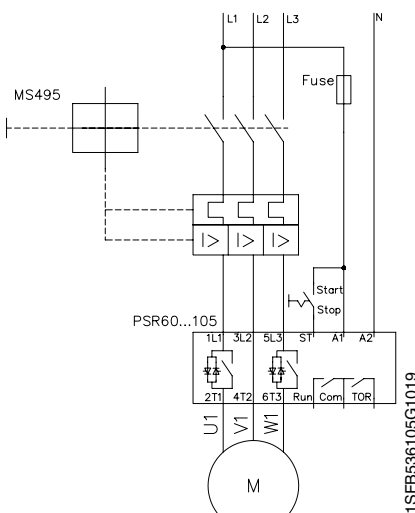

H) With MMS and auxiliary contact

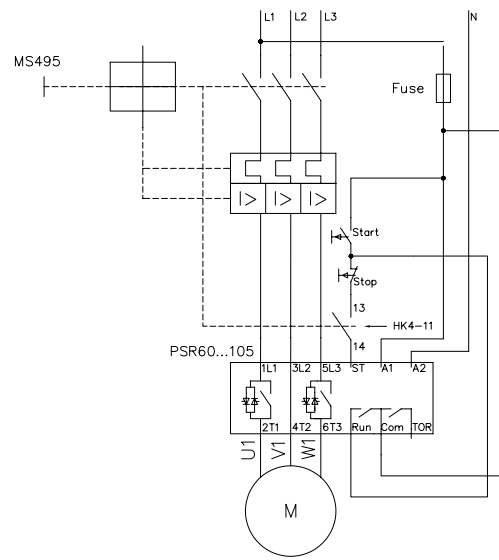

I) With fuses, contactor and O.L.

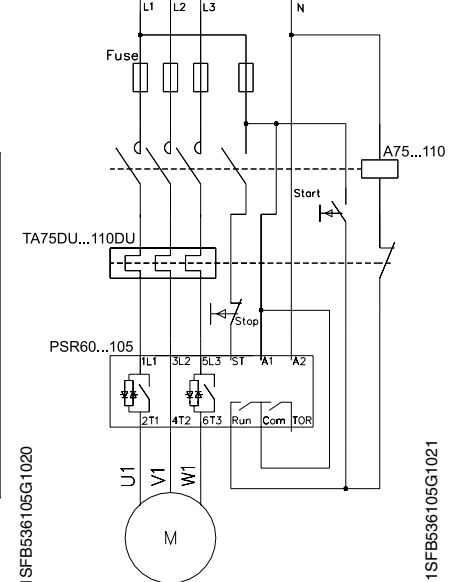

Softstarters

Type PSS18/30 ... PSS300/515

Diagrams

PSS18/30...300/515

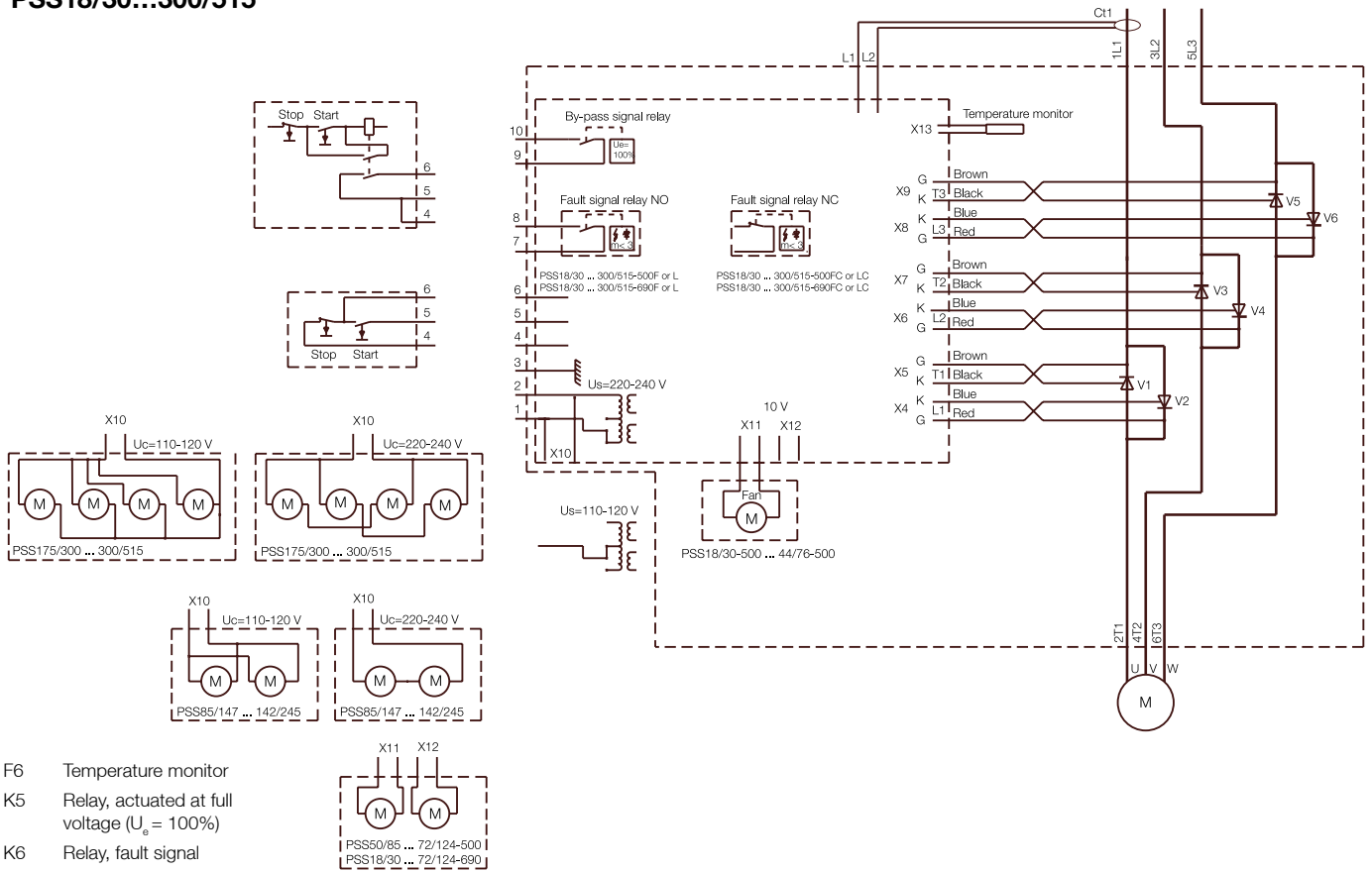

- F6 Temperature monitor
- K5 Relay, actuated at full voltage ($U_e = 100\%$)
- K6 Relay, fault signal
- T1 Control transformer
- T2 Current transformer
- V1-V6 Thyristor

Softstarters

Type PST30 ... 300 and PSTB370 ... 1050 Diagrams

PST30...300

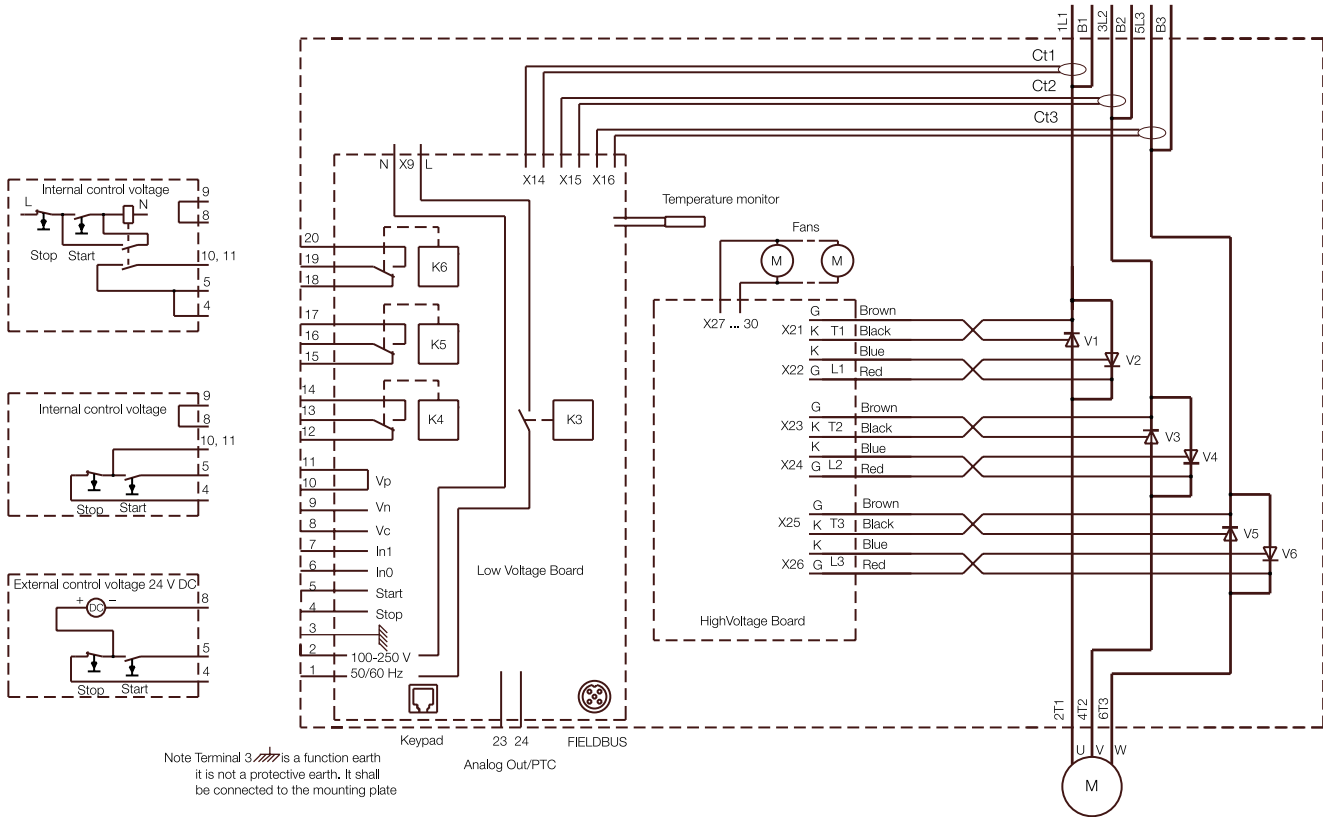

PSTB370...1050

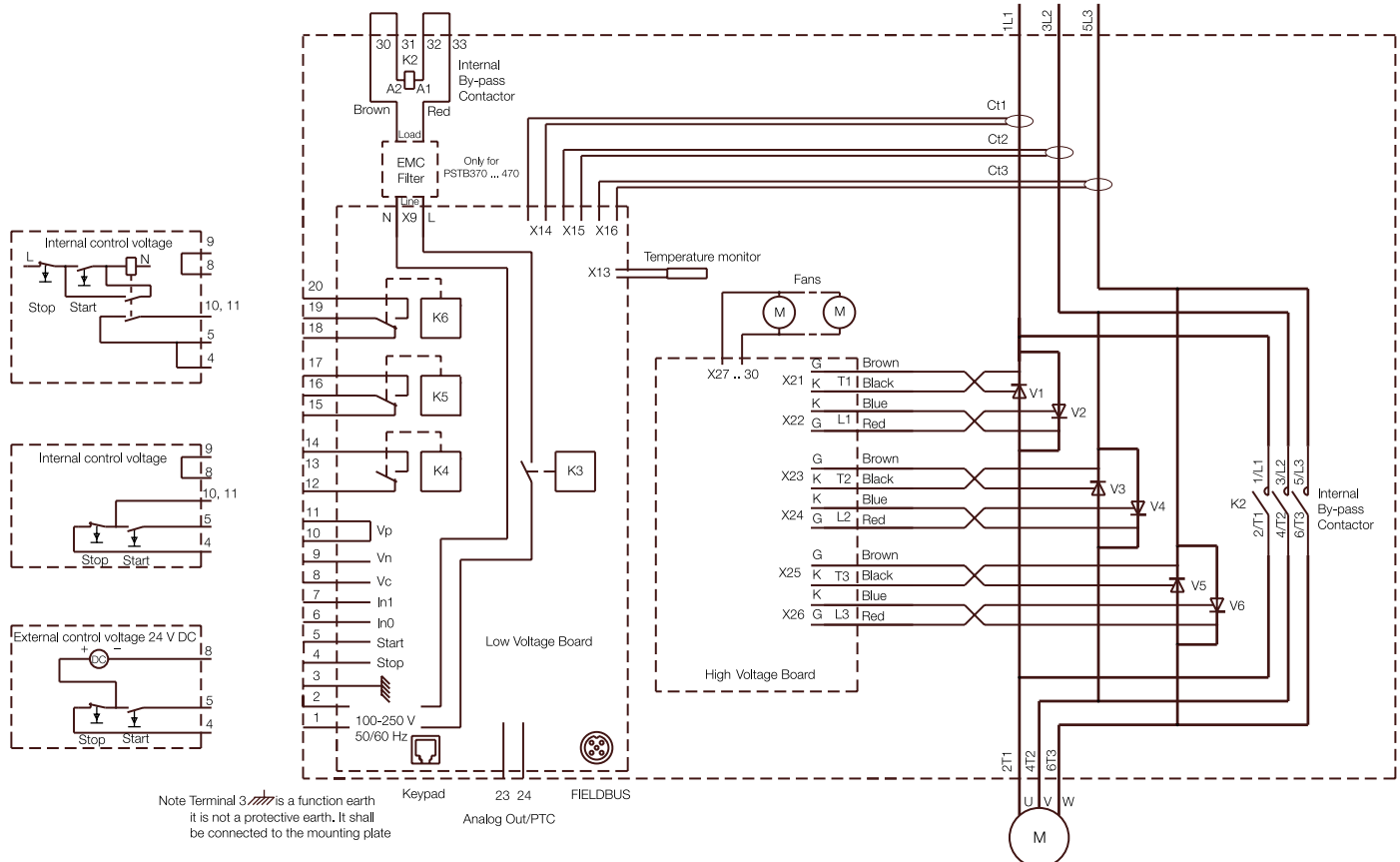

Softstarters











Type PSR, PSS, PST and PSTB

Certifications, Approvals, Directives and Standards

The table below shows the approvals and certifications for different softstarters.

For approvals and/or certificates not listed below, please contact your local ABB sales office.

Certifications and approvals

Abbreviation Approved in	Certifications							Approvals: ship classification societies			
	 CE EU	 UL USA	 cULus Canada USA	 CSA Canada	 CCC China	 GOST Russia	 ANCE Mexico	 C-tick Australia	 ABS American Bureau of Shipping	 Lloyd's Register EMEA	 GL Germany
PSR3 ... PSR105											
PSR3 ...PSR105	•	(•)	•	(•)	•	•	–	•	–	–	–
PSS18/30...300/215											
PSS18/30 ... PSS72/124	•	•	–	•	•	•	•	•	–	•	–
PSS85/147 ... PSS300/515	•	•	–	•	•	•	•	•	–	–	–
PST30...PSTB1050											
PST30 ... PSTB1050	•	•	–	•	•	•	•	•	•	–	•

- **Standard design approved**, the company labels bear the certification mark when this is required.

Directives and Standards

No. 2006/95/EC	Low voltage equipment
No. 2004/108/EC	Electromagnetic compability
EN 60947-1	Low-voltage switchgear and controlgear - Part 1: General rules
EN 60947-4-2	AC semiconductor motor controllers and starters
UL 508	Industrial Control Equipment
CSA C22.2 No 14	Industrial Control Equipment

Leader in power and automation technologies

ABB (www.abb.com) is a leader in power and automation technologies that enable utility and industry customers to improve performance while lowering environmental impact. The ABB Group of companies operates in around 100 countries and employs about 112 000 people.

Division Automation Products

The division Automation Products serves customers in the automotive, chemicals, consumer, electronics, life sciences, manufacturing, marine, metals, minerals, paper, petroleum, turbochargers and utility industries.

Besides strong domain knowledge of the industries we serve, our offer includes measurement, control, communication, instrumentation, drives, motors, power electronics, software and a broad range of low-voltage products. Much of this is sold through external channel partners such as distributors, system integrators, contractors and original equipment manufacturers.

Low voltage products

Due to ABB's broad program of product standardization, components of today are the 'building blocks' of system solutions, incorporating functionalities that will allow seamless integration in real-time automation and information systems.

At the product level, all the low voltage products can operate together perfectly.

To create a system solution every product included has to be equipped with the tools necessary to install, operate and maintain it efficiently throughout the product life cycle.

The range of low voltage product is supported by technical documentation. This together with design and compact unit makes it easier than ever to incorporate our products in your system.

Our customers can find all product related documentation such as brochures, catalogues, selection program, certificates, drawings and other information directly at: www.abb.com/lowvoltage.





ABB AB

Cewe-Control
SE-721 61 Västerås, Sweden
Telephone +46 21 32 07 00
Telefax +46 121 12 60 01

<http://www.abb.com/lowvoltage>