

Softstarters PSS18/30...300/515

AC 1005.1

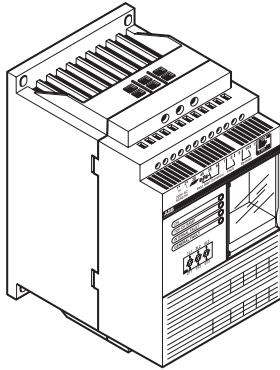

PSS18/30-500...44/76-500

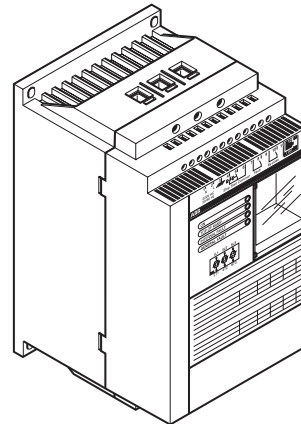

PSS50/85-500...72/124-500
PSS18/30-690...72/124-690

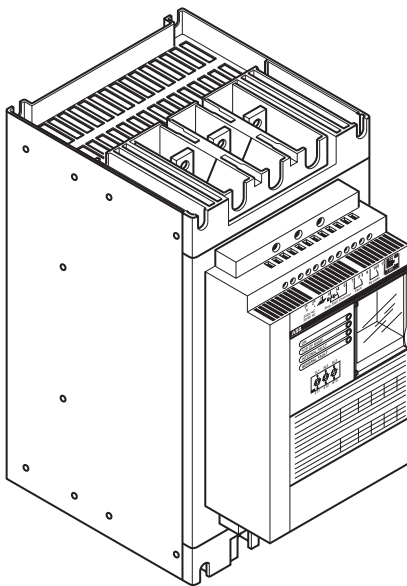

PSS85/147-500...142/245-500
PSS85/147-690...142/245-690

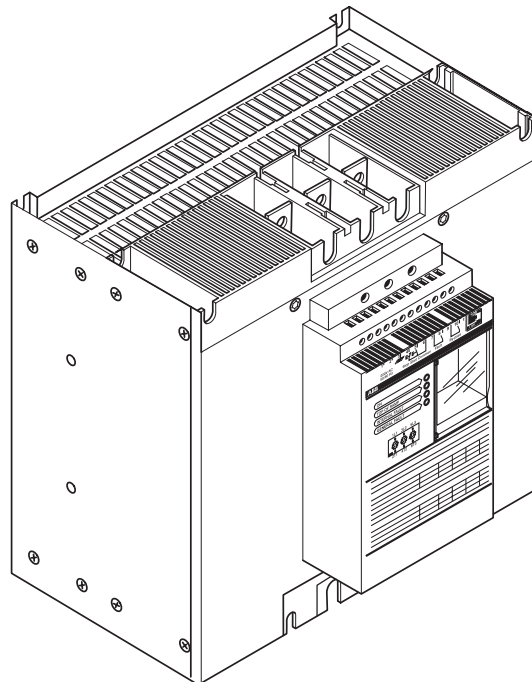

PSS175/300-500...300/515-500
PSS175/300-690...300/515-690

Table of contents

1. Softstarter markings	3
2. Mounting	
2.1 Drilling plan	4
2.2 Minimum distance to wall/front	4
3. Connection	
3.1 Line side & load side connections	5
3.2 Control voltage and control circuit	6
4. Setting	
4.1 Start ramp	9
4.2 Stop ramp	9
4.3 Initial voltage (U_{INI}) / Current limit function (I_{LIM})	9
4.4 Line/Delta switch S1	10
4.5 Basic settings for various applications	11
5. Maintenance	12
6. Trouble shooting.....	13 - 14
7. Changing thyristor modules	15
8. Changing a printed circuit board.....	16
9. Spare parts	17
10. Circuit diagrams.....	18 - 20
11. Approximate dimensions.....	21 - 22



WARNING

The operation, installation and servicing of this product must be carried out by a qualified electrician, following installation standards and safety regulations. Check that you have the correct softstarter unit in regards to system voltage, rated motor data and type of connection.

1. Softstarter marking

! These softstarters fulfill the demands according to 89/336/EEC and EN 60947-4-2 / IEC 947-4-2, Equipment Class A.

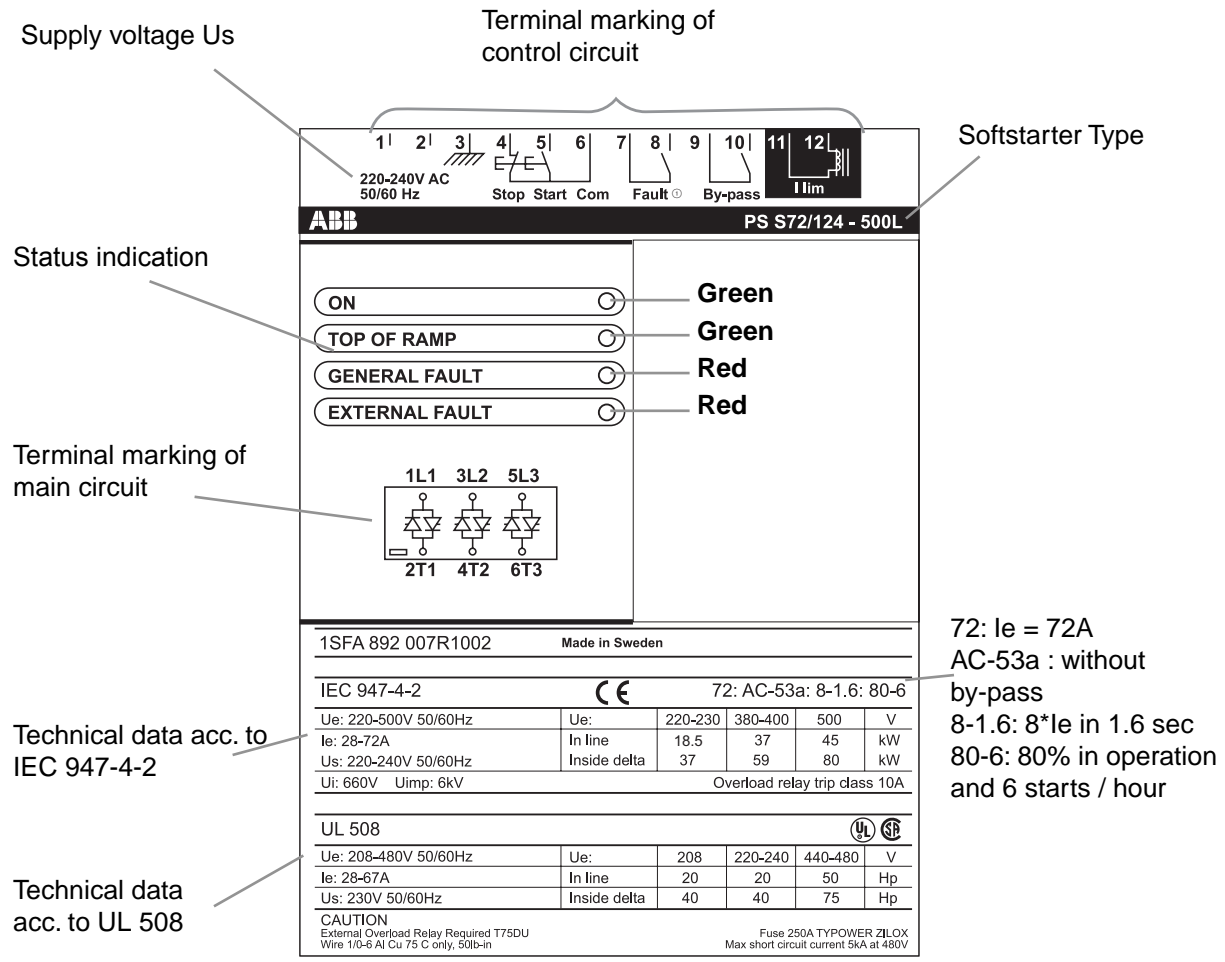

Picture 1.1

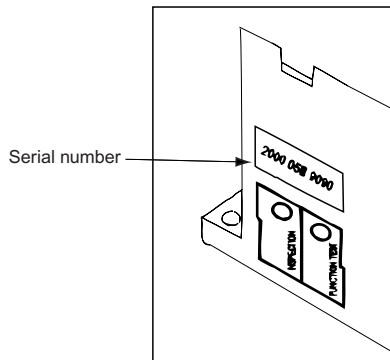

① Can also be ordered as a normally closed fault contact.

2. Mounting

To have suitable cooling, the softstarter has to be mounted vertically, see picture 2.1.

The softstarter should not be mounted in a position that blocks the airways. Follow recommended distances according to section 2.2.

! All technical data for the softstarter are valid for an ambient temperature of 40°C. For temperatures above 40°C, up to max. 60°C, the rated current must be derated by 0.8% per °C.

! A bypass contactor must be used when placing in any enclosure other than NEMA 1 ventilated.

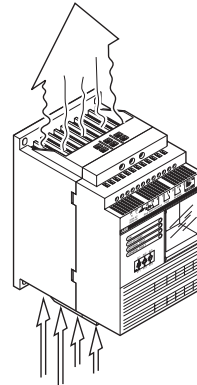

Picture 2.1

2.1 Drilling plan (mm)

Softstarter size	K	L	M
PSS18/30-500...44/76-500	105	184	M6
PSS50/85-500...72/124-500 PSS18/30-690...72/124-690	125	234	M6
PSS85/147-500...142/245-500 PSS85/147-690...142/245-690	158	320	M6
PSS175/300-500...300/515-500 PSS175/300-690...300/515-690	333	320	M6

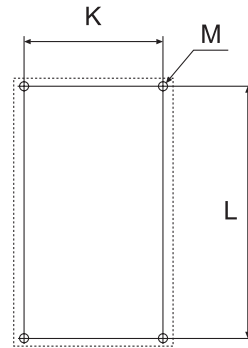

Picture 2.2

2.2 Minimum distance to wall/front

The following distances give enough clearance for airflow around the softstarter for suitable cooling. Please note that the values are minimum distances.

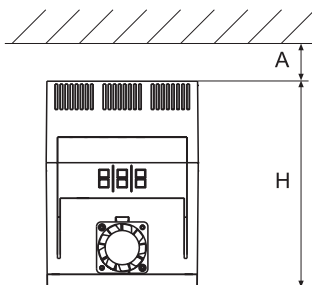

Picture 2.3

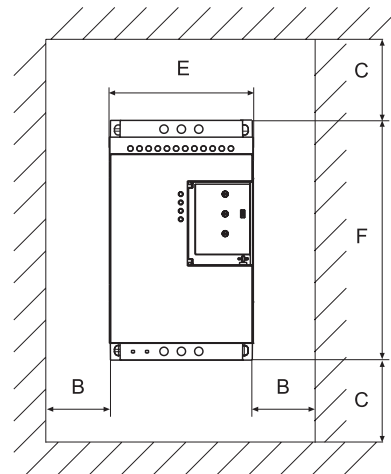

Picture 2.4

	Air gap (mm)			Outer dimensions of the softstarter (mm)		
	A	B	C	E	F	H
PSS18/30-500...44/76-500	20	10	100	120	200	163
PSS50/85-500...72/124-500 PSS18/30-690...72/124-690	20	10	100	140	250	163
PSS85/147-500...142/245-500 PSS85/147-690...142/245-690	20	10	100	181	340	265
PSS175/300-500...300/515-500 PSS175/300-690...300/515-690	20	10	100	356	340	265

3. Connection

3.1 Line side and load side connections

All softstarters, PSS18/30 to PSS142/245, can be connected "In Line" (see picture 3.1) or "Inside Delta" (see picture 3.2) with the motor.

! Remember to set the Line/Delta switch S1 in the right position. See page 10.

! See Section 3.2.6 on page 8 for current transformer mounting information.

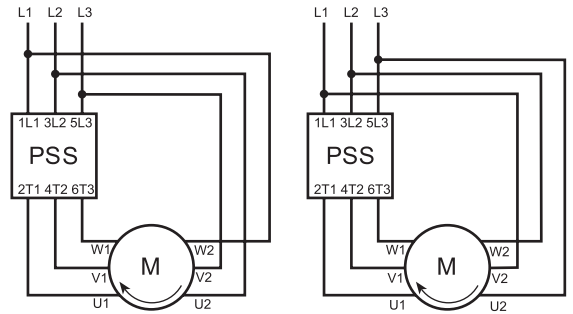

Picture 3.2

Connect the line side to terminals / bars 1L1, 3L2, 5L3 and motor side to terminals / bars 2T1, 4T2 and 6T3. The terminal markings are printed on the front panel of the softstarter.

! The softstarter unit is not phase sequence sensitive.



Picture 3.1

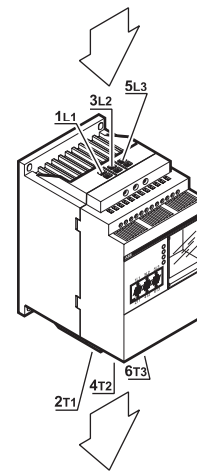

Picture 3.3

PSS18/30-500...44/76-500 		 2.3 Nm - 20 lb/in			
PSS50/85-500...72/124-500 PSS18/30-690...72/124-690 		 4 Nm - 35 lb/in			
PSS85/147-500...142/245-500 PSS85/147-690...142/245-690 		 9 Nm - 80 lb/in			
PSS175/300-500...300/515-500 PSS175/300-690...300/515-690 		 18 Nm - 160 lb/in			

3. Connection

3.2 Control voltage and control circuit

3.2.1 Supply voltage, terminals 1 and 2

Connect neutral and phase to terminal 1 and 2. See picture 3.4

! Check that you have the correct supply voltage Us.

3.2.2 Grounding of the unit, terminal 3

Suitable cable: green/yellow , AWG12...16

The cable should be as short as possible and shall be connected to a grounding point close to the softstarter. A suitable grounding point would be next to the softstarter on the mounting plate. See picture 3.6. The mounting plate should also be grounded.

! The grounding cable should be as short as possible and should be connected to a grounding point close to the softstarter.

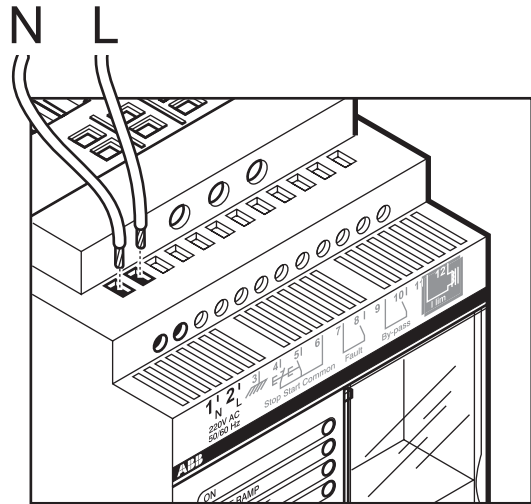

Picture 3.4

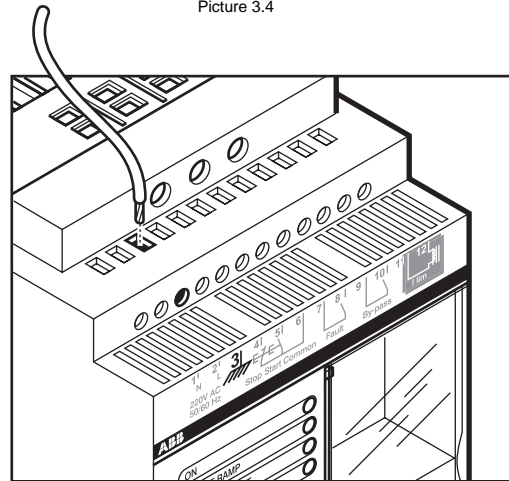

Picture 3.5

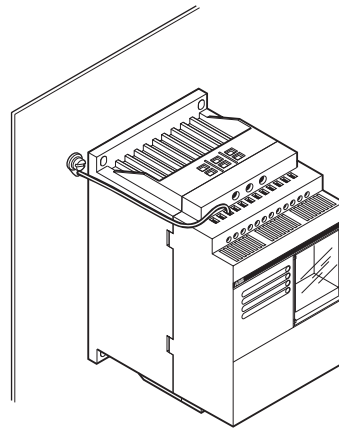

Picture 3.6

	<p>M 3</p> <p>0.5 Nm - 4.3 lb/in</p>	<p>ø 4</p>	<p>0.14 ... 2.5 mm² AWG 12...22 0.14 ... 2.5 mm²</p>
--	--------------------------------------	------------	--

3. Connection

3.2.3 Control circuit for Start and Stop, Terminals 4, 5 and 6

The softstarter has a built in holding circuit. See picture 3.8

A conventional circuit with an auxiliary relay is also possible.
See picture 3.9

! Do not connect voltage to terminals 4, 5 or 6. The softstarter has it's own internal voltage for the holding circuit.

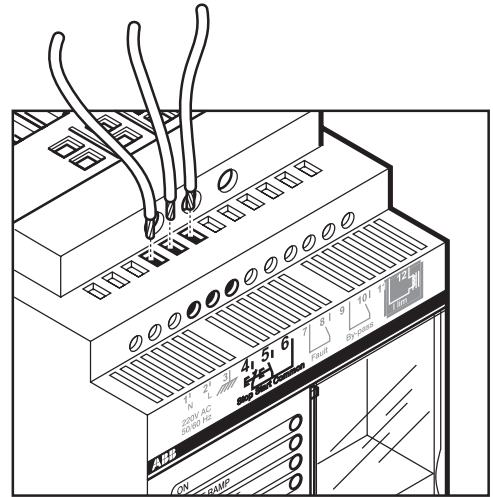
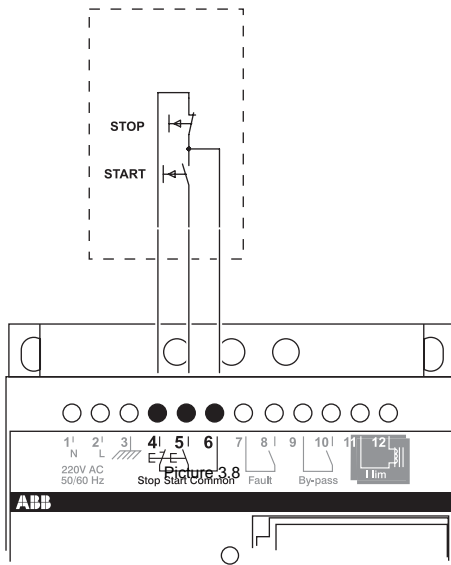

Picture 3.7

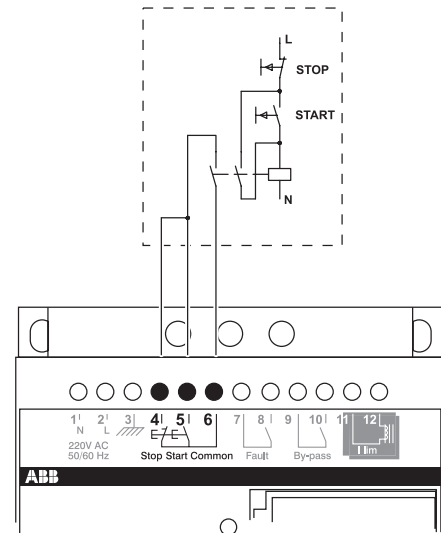

Picture 3.9

3.2.4 Signal relay for fault. Terminals 7 and 8 : Fault

The built in contact provides a signal (normally open contact)Ⓞ when a fault condition occurs.

Technical data: max 250V / 1.5A, AC-15.

3.2.5 Signal relay for indication of completed start ramp. Terminals 9 and 10 : By-pass

The built in contact is closed when the start ramp is completed, and opened when a stop signal is given (closed only during continuous operation).

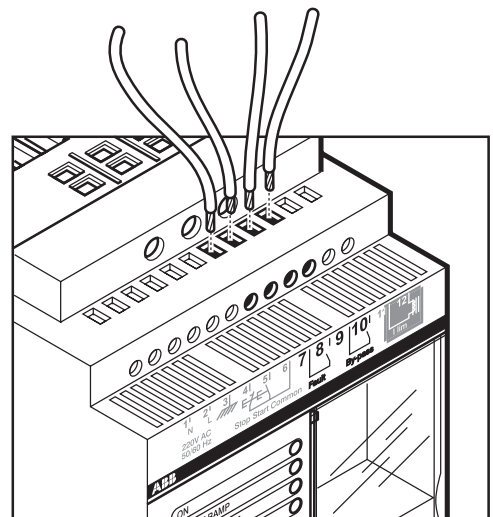

Picture 3.10

Ⓞ Can also be ordered as a normally closed fault contact.

3. Connection

3.2.6 Connection of current transformer T2 (accessory), Terminal 11 and 12

The "Current Limit" function requires a current transformer to be connected to terminals 11 and 12. The current transformer is an accessory, which can be purchased separately.

! Check that you have the correct current transformer (correct ratio).
■ See table 3.1

Mounting

Mount the current transformer close to the softstarter, see pictures 3.11 and 3.12.

Connection

The current transformer can be connected to a phase of your choice. Pictures 3.13 and 3.14 show possible installation points.

Check Table 3.1 to determine how many turns you need for the primary side of the transformer. Connect the transformer according to picture 3.12 for one turn, or according to picture 3.11 for two turns.

The smallest cable size which can be used is AWG 16.

A different current transformer from a local supplier can also be used
 – technical data : 1VA minimum

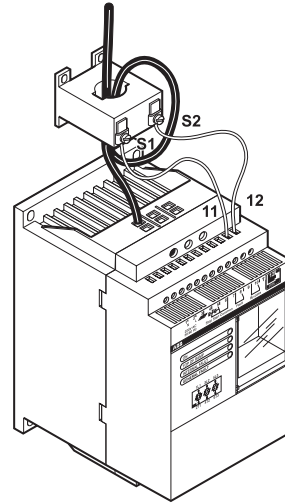

Picture 3.11

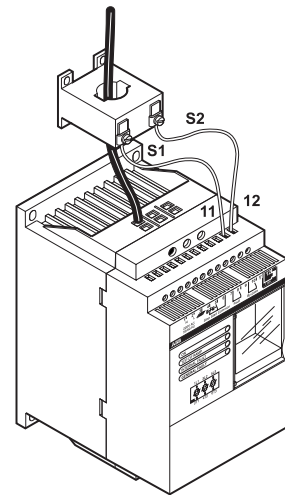

Picture 3.12



Picture 3.13

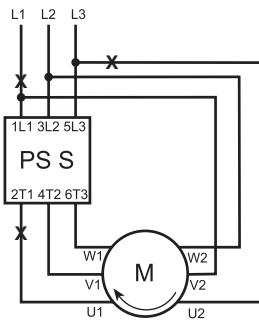

Picture 3.14

Table 3.1

For softstarter	Ratio	Turns	Connection Picture No.
PSS18/30	60/1	2	3.11
PSS30/52	40/1	1	3.12
PSS37/64	50/1	1	3.12
PSS44/76	60/1	1	3.12
PSS50/85	75/1	1	3.12
PSS60/105	75/1	1	3.12
PSS72/124	100/1	1	3.12
PSS85/147	125/1	1	3.12
PSS105/181	150/1	1	3.12
PSS142/245	200/1	1	3.12
PSS175/300	250/1	1	3.12
PSS250/430	400/1	1	3.12
PSS300/515	400/1	1	3.12

4. Setting

The softstarter has three rotating switches as well as one 2-position switch. Basic settings for various applications are listed in the tables on page 11.

4.1 Start ramp

Sets the time for how fast the voltage will be increased during start. Adjustable in 16 steps between 1 and 30 seconds. See picture 4.2.

4.2 Stop ramp

Sets the time for how fast the voltage will be decreased during stop. Adjustable in 16 steps between 0 and 30 seconds. See picture 4.3.

4.3 Initial voltage (U_{INI}) / Current Limit Function (I_{LIM})

4.3.1 Initial voltage (U_{INI})

WHITE scale

Sets the starting voltage level for the start ramp, as well as the end voltage of the stop ramp.

Adjustable in 5 steps between 30% and 70% of full voltage.

4.3.2 Current limit function (I_{LIM})

A softstarter always reduces starting current.

The current limit function allows you to pre-set a maximum starting current which will never be exceeded.

BLUE scale

The same rotating switch as for initial voltage (U_{INI}). Sets the current limit if a current transformer T2 is connected to terminals 11 and 12.

Adjustable in 11 steps between 1.5 and 4 times the current transformers ratio. When setting the parameter (I_{LIM}) on the blue scale, the initial voltage (U_{INI}) will always be a fixed value of 40%.

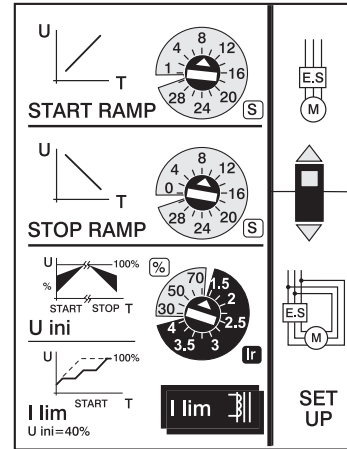

Picture 4.1

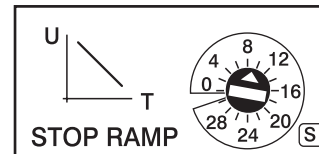

Picture 4.2

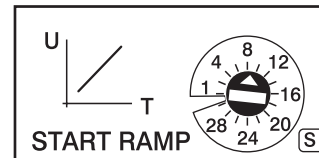

Picture 4.3

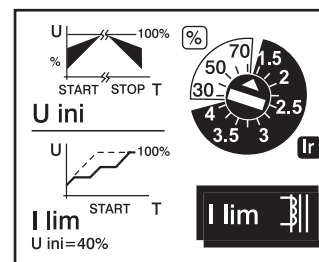

Picture 4.4

4. Setting

4.4 Line/Delta switch S1

The softstarter can be connected to the main circuit in two different ways: "In Line" with the motor (see picture 4.6) or "Inside Delta" with the motor (see picture 4.7). Set this switch in the position corresponding to the chosen connection type (see picture 4.5).

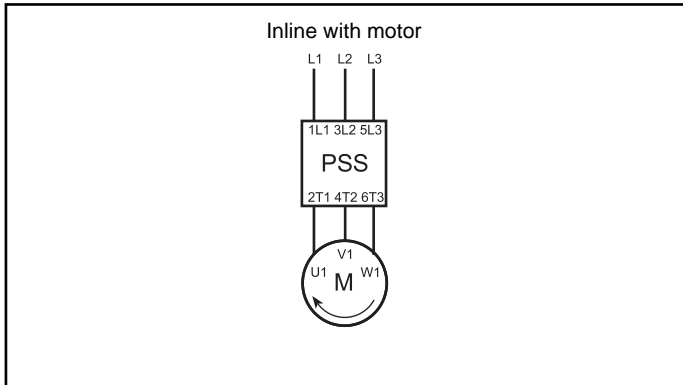

Picture 4.6

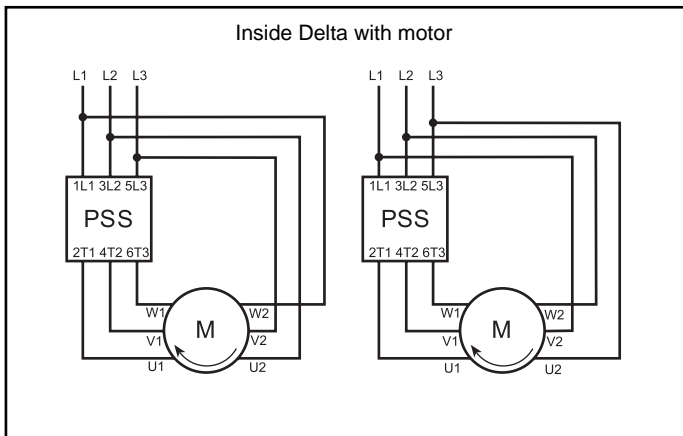

Picture 4.7

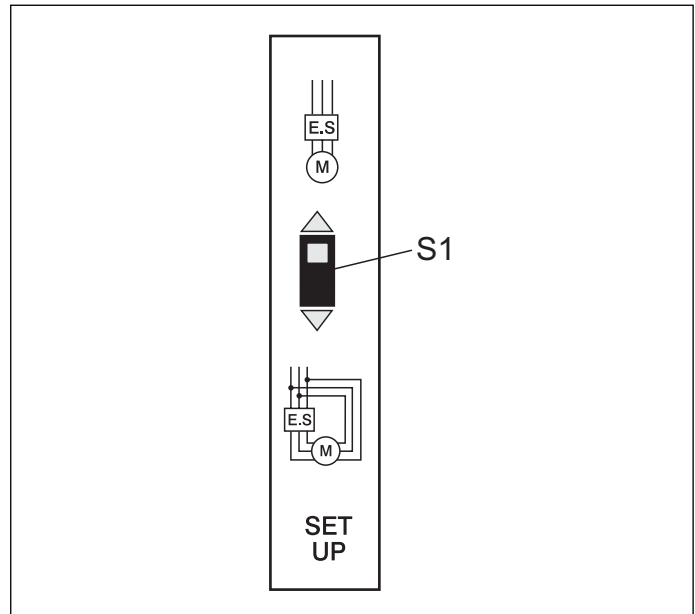

Picture 4.5

4. Setting

4.5 Basic settings for different applications

4.5.1 Without current transformer T2 connected

Table 4.1

Type of load	Ramp time for start (sec)	Ramp time for stop (sec)	Initial voltage U_{INI}
Bow thruster	10	0	30%
Centrifugal fan		0	30%
Centrifugal pump		20	30%
Piston compressor		0	30%
Lifting equipment		10	60%
Rotary converter		0	30%
Stirrer, Mixer		0	60%
Scraper		10	40%
Screw compressor		0	40%
Screw conveyor		10	40%
Unloaded motor		0	30%
Conveyor belt		10	40%
Heat pump		20	30%
Escalator		0	30%
Hydraulic pump		0	30%

4.5.2 With current transformer T2 connected

Table 4.2

Type of load	Ramp time for start (sec)	Ramp time for stop (sec)	Initial voltage U_{INI} (Fixed value)	Current limit I_{LIM} (xle) (start)
Bow thruster	10	0	40%	2.5
Centrifugal fan		0		3.5
Centrifugal pump		20		3.0
Piston compressor		0		3.0
Lifting equipment		10		3.5
Rotary converter		0		2.5
Stirrer, Mixer		0		3.5
Scraper		10		3.5
Screw compressor		0		3.5
Screw conveyor		10		3.5
Unloaded motor		0		2.5
Conveyor belt		10		3.5
Heat pump		20		3.0
Escalator		0		3.0
Hydraulic pump		0		2.5

5. Maintenance

Check that the cooling airways of the softstarter unit are free from dirt and dust. Check also that the fan is working and rotating freely. The fan can be checked when voltage is not applied. The fan blades should rotate freely without heavy resistance when voltage is not applied.

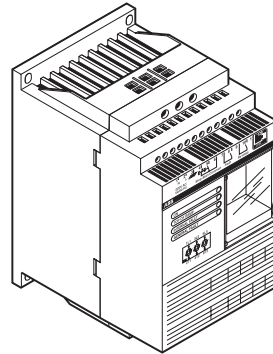

6. Trouble shooting

Motor humming / starts without given start signal

Status / Indication

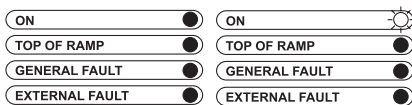

Check

- One or several thyristors can be shorted / broken.
- Is the by-pass contactor stuck in closed position?

Motor does not start

Status / Indication

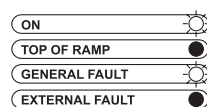
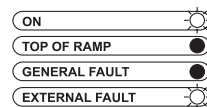
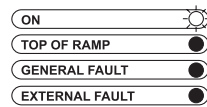
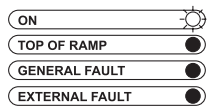

Check

- Is supply voltage connected to terminal 1 and 2?

- Is start signal given (closed circuit between terminals 5 and 6)?
- Is the circuit closed between terminals 6 and 4?
- Verify that start and stop signals are not given at the same time.
- Is the Line/Delta switch S1 in the right position?

- Is the correct frequency connected?
- Is the Line/Delta switch S1 in the right position?
- Is the Inside Delta connection wired properly?
- Is main voltage connected to terminals 1L1, 3L2 and 5L3?
- Has the thermal overload relay tripped and opened the main contactor?
- Check all connections.

RESET: Give stop signal or disconnect voltage from terminals 1 and 2.

- Is the Line/Delta switch S1 in the right position?
- Is there an overtemperature in the softstarter? The same fault will occur again after RESET, if the softstarter is still too warm. Check that the fans are working properly. Also check that cooling airways are free from dirt and dust.
- If it is not possible to RESET the fault, then the processor is faulty.
- If a fault occurs approx. 60-70 sec after start signal is given, then the softstarter tries to ramp up but is not succeeding. Check all connections.
- If current transformer is used: Is the current limit settings high enough? Is the ratio of the current transformer right?
- If inside delta connection is used: Is the motor circuit closed and are the connections correct?

RESET: Give stop signal or disconnect voltage from terminals 1 and 2.

6. Trouble shooting

Motor stops during start / continuous operation

Status / Indication

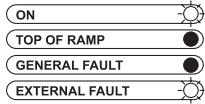

Check

- Phase loss in the main circuit? Has the thermal overload relay tripped and opened the main contactor? Has a fuse blown?
 - Check all connections.
- RESET:** Give stop signal or disconnect voltage from terminals 1 and 2.

Status / Indication

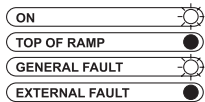

Check

- Is there an overtemperature in the softstarter? The same fault will occur again after RESET, if the softstarter is still too warm. Check that the fans are working properly. Also check that cooling airways are free from dirt and dust.
 - If it is not possible to RESET the fault, then the processor is faulty.
 - If a fault occurs approx. 60-70 sec after start signal is given, then the softstarter is trying to ramp up but is not succeeding. Check all connections.
 - Phase loss between softstarter and motor? Check connections.
 - One or more thyristor pairs are shorted / broken.
 - Is the Line/Delta switch S1 in position "In Line", even though the softstarter is connected "Inside Delta"?
 - If inside delta connection is used: Is the motor circuit closed and are the connections correct?
- RESET:** Give stop signal or disconnect voltage from terminals 1 and 2.

Fault at stop

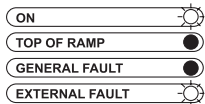

- Phase loss in the main circuit? Has main contactor opened before stop ramp has finished? Has a fuse blown?
- Is the by-pass contactor stuck in closed position?

RESET: Give both start and stop signal or disconnect voltage from terminals 1 and 2.

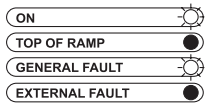

- Phase loss on load side? Check connections.

RESET: First give start signal, then stop signal or disconnect voltage from terminals 1 and 2.

6. Trouble shooting

Bad motor sound during start and operation

Status / Indication

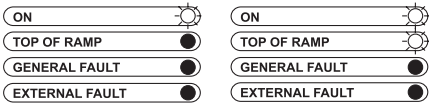

Check

- Is the motor too small?
- Is the Line/Delta switch S1 in the right position?
- Is the "Inside Delta" connection wired properly?
- Phase loss on line or load side? Check connections.

Bad motor sound during stop or stop ramp finish too early

Status / Indication

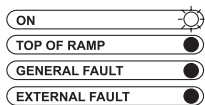

Check

- Try different ramp time for stop (some adjustment may be necessary for best result).
- Phase loss on line or load side? Check connections.
- Is the Line/Delta switch S1 in the right position?

! Soft stop should only be used for applications where the motor stops too quickly with direct stop. See tables on page 11.

Current limit function not adjustable (only valid for start)

Status / Indication

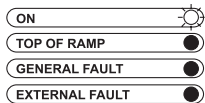

Check

- Is a current transformer connected to terminals 11 and 12?
- Is the rotating switch for parameter I_{LIM} turned to the blue scale?
- Is the correct current transformer used?
- Is the current transformer connected correctly?
- Is the motor suitable for the softstarter (motor too small)?

Other combination of LED:s than above:

- View LEDs straight from the front, otherwise the neighboring LED may seem to be lit.
- The printed circuitboard in the softstarter is faulty

! In some cases the actual ramp time can differ from the set value. If motor starts/stops softly, then everything is OK.

7. Changing Thyristor modules

General

The life span of electronics can be affected by damage caused by electrostatic discharge. This can happen if a component is touched by a charged tool or person. Therefore it is very important that all tools and personnel are discharged by touching a grounded point before the printed circuit board or any of the components are touched. It is equally important to discharge the package with the new component before opening it.

A person walking on a carpet can be charged with up to fifteen thousand volts (15000V). Some sensitive components can be destroyed when discharged on a much lower level (about 100V). Please pay notice to this as this is vital information in ensuring the life span of the product.

Handling

Modules and heat sinks are to be handled carefully to avoid scratches and other marks. Avoid touching the contact surfaces.

Steps to change thyristors:

1. Disconnect the voltage from terminals 1L1, 3L2, and 5L3 (main supply).
2. Disconnect all cable from terminals 1-12.
3. Remove the front cover.
4. Discharge the tools and yourself by touching a grounded system.
5. Disconnect the electrical connection on the thyristors.
6. Remove the thyristors.
7. Clean the contact surface on the heat sink and modules with Ethanol. Use lint-free cloth (paper or linen cloth).
8. Place a very thin layer of heat transfer compound on the contact surfaces of the modules with a lint-free cloth. Too much compound between the module and heat sink will give bad thermal conduction and cause risk of overheating the thyristors.
9. Mount the new thyristors (Use the torque in table 1).
10. Mount the electrical connections to the thyristors.
11. Mount the front cover

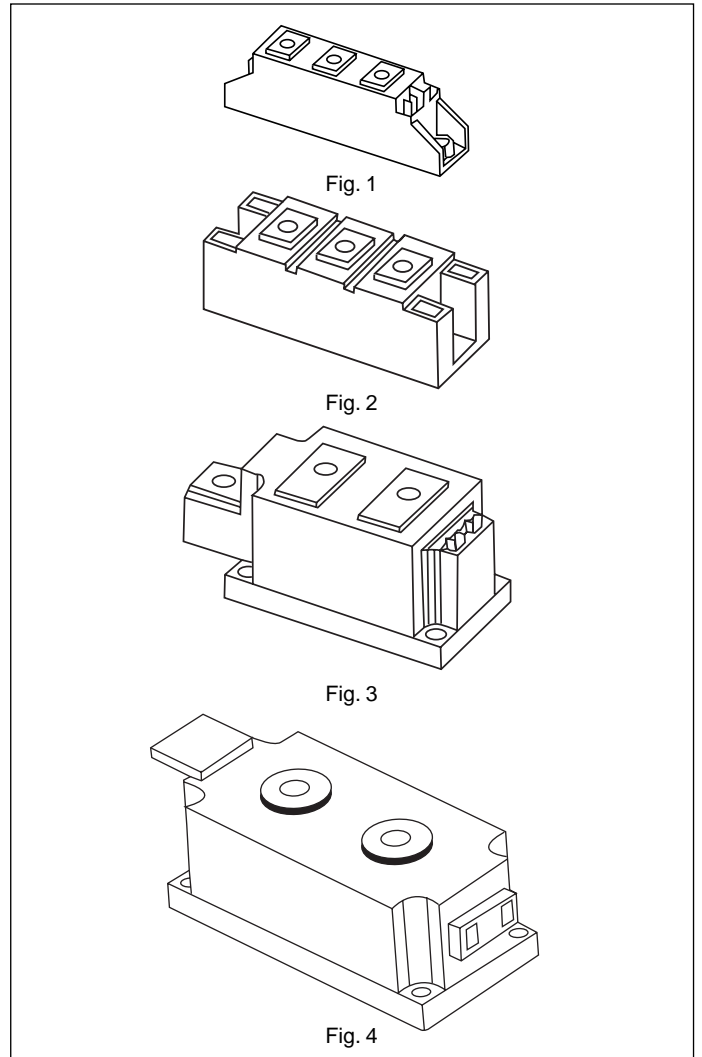

Figure No.	Hardware torque	Wire torque
1	26 lb/in	26 lb/in
2	26 lb/in	43 lb/in
3	26 lb/in	77 lb/in
4	26 lb/in	77 lb/in

9. Spare parts

Printed circuit boards

Softstart type	Fig No.	Main PCB 230V - 500V Catalog number	Main PCB 380V - 690V Catalog number
PSS18 – 300	1	PSPCB –500/S	PSPCB –690/S

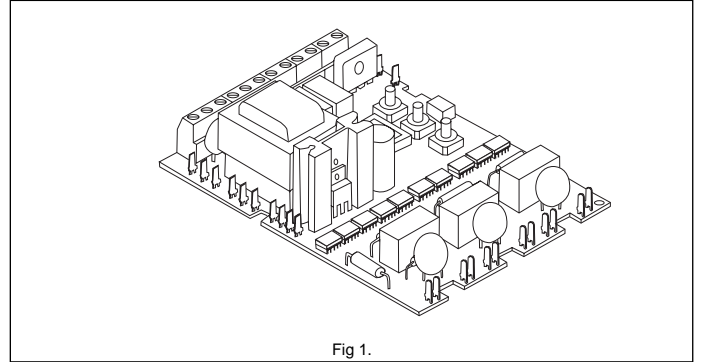

Fig. 1.

Cooling fan

Softstart type	Voltage	Pcs per softstart	Fig. no. unit	Catalog number
PSS18 – 44	500V	1	2	PSFA-12
PSS50 – 72	500V	2	2	PSFA-12
PSS18 – 72	690V	2	2	PSFA-12
PSS85 – 142	500/690V	2	3	PSFA-115
PSS175 – 300	500/690V	4	3	PSFA-115

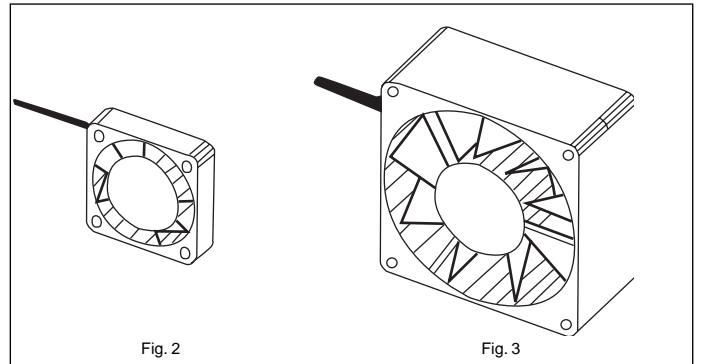

Fig. 2

Fig. 3

Thyristors

Softstart type	Pcs per softstart unit	Fig no	Thyristor <=500V Catalog number	Thyristor <=690V Catalog number
PSS18	3	4	PSTM-27/16	PSTM-27/18
PSS30	3	4	PSTM-42/16	PSTM-42/18
PSS37	3	4	PSTM-57/16	PSTM-57/18
PSS44	3	4	PSTM-92/16	PSTM-92/18
PSS50	3	4	PSTM-92/16	PSTM-92/18
PSS60	3	5	PSTM-132/16	PSTM-132/18
PSS72	3	5	PSTM-172/16	PSTM-172/18
PSS80	3	5	PSTM-172/16	PSTM-172/18
PSS105	3	6	PSTM-210/16	PSTM-210/18
PSS142	3	6	PSTM-250/16	PSTM-250/18
PSS175	3	6	PSTM-250/16	PSTM-250/18
PSS250	3	7	PSTM-500/16	PSTM-500/18
PSS300	3	7	PSTM-500/16	PSTM-500/18

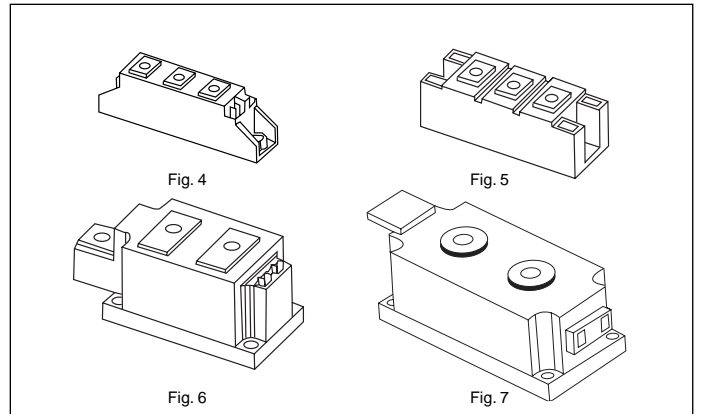

Fig. 4

Fig. 5

Fig. 6

Fig. 7

Kit for changing thyristors

Softstart type	Fig No.	Kit Catalog number
PSS18 – 300	8	PSPB-1

Sufficient for replacing 10 thyristor blocks.

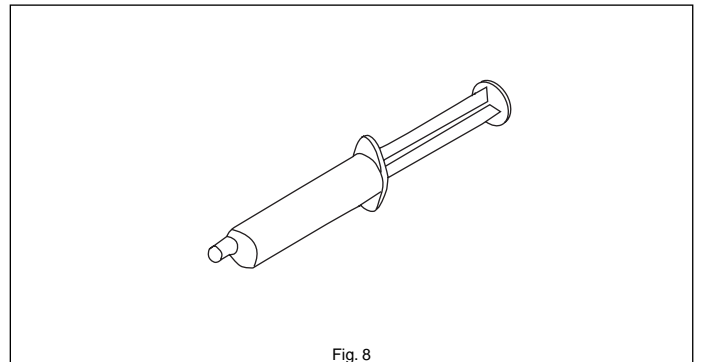

Fig. 8

10. Circuit diagram

Type PSS, Circuit diagrams

PSS18/30 – PSS300/515, In-line motor configuration

10.1 Circuit diagram – In line motor configuration

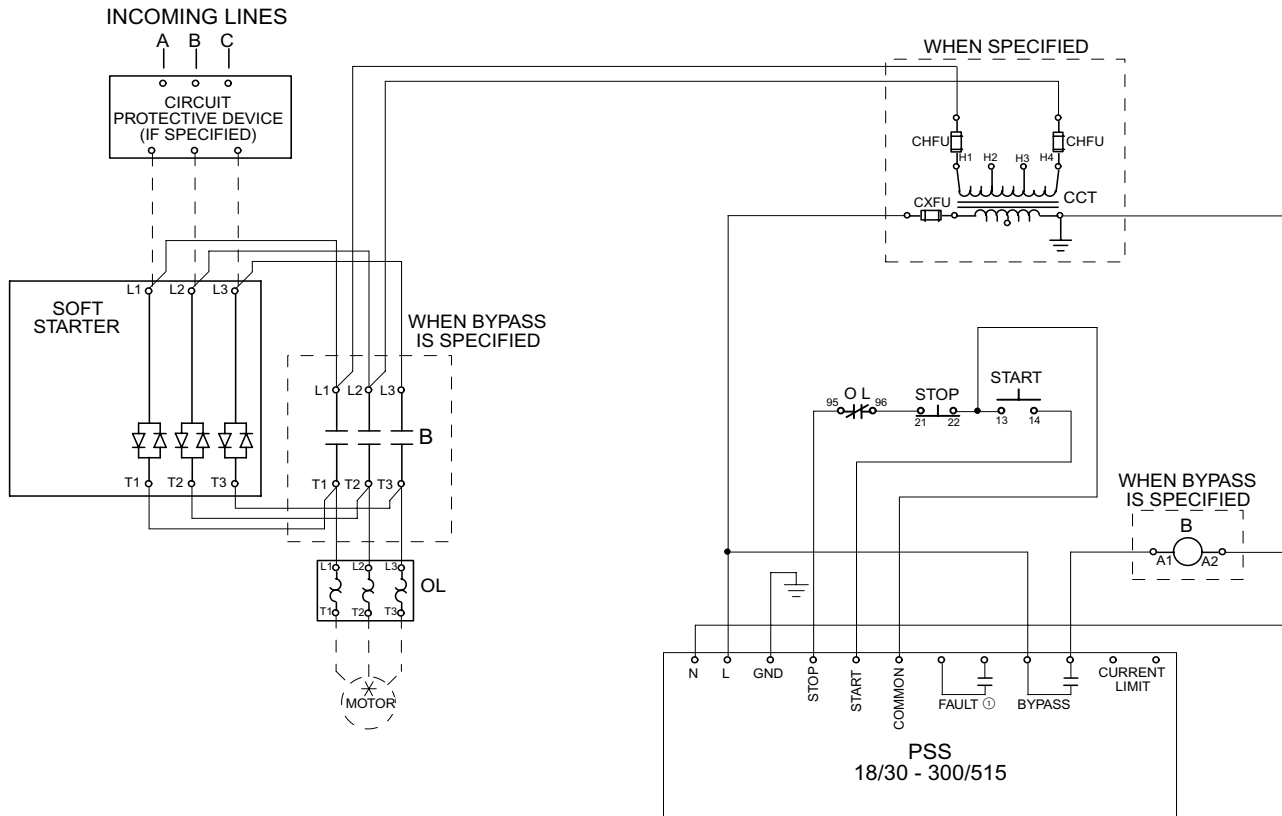

NOTES

- ALL CONTROL WIRING TO BE 18GA. COLOR OF CONTROL WIRE SHALL BE PER VOLTAGE OF CONTACTOR COILS:
 RED - ALL AC VOLTAGES
 WHITE MAY BE USED ON THE GROUNDED SIDE OF THE AC CIRCUIT IF SPECIFIED.
 BLUE - ALL DC VOLTAGES
- ALL DEVICES ARE SHOWN DE-ENERGIZED.
- DO NOT USE SELECTOR SWITCHES WITH AUTO-RESET OVERLOAD RELAYS.

LEGEND	
CCT	CONTROL CIRCUIT TRANSFORMER
CHF	CCT PRIMARY FUSE
CXF	CCT SECONDARY FUSE
B	BYPASS CONTACTOR
OL	OVERLOAD RELAY
13	CONN POINT ON DEVICE WITH NUMBER
X	REMOTE DEVICE
∅	CONN POINT AT TERMINAL BLOCK

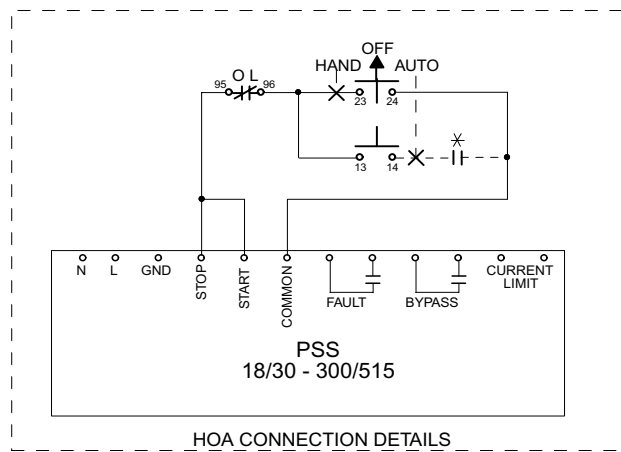
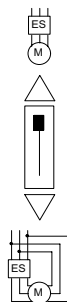

HOA CONNECTION DETAILS

① Can also be ordered as a normally closed fault contact.

10. Circuit diagram

Type PSS, Circuit diagrams

PSS18/30 – PSS300/515, Delta motor configuration

10.2 Circuit diagram – Delta Motor configuration

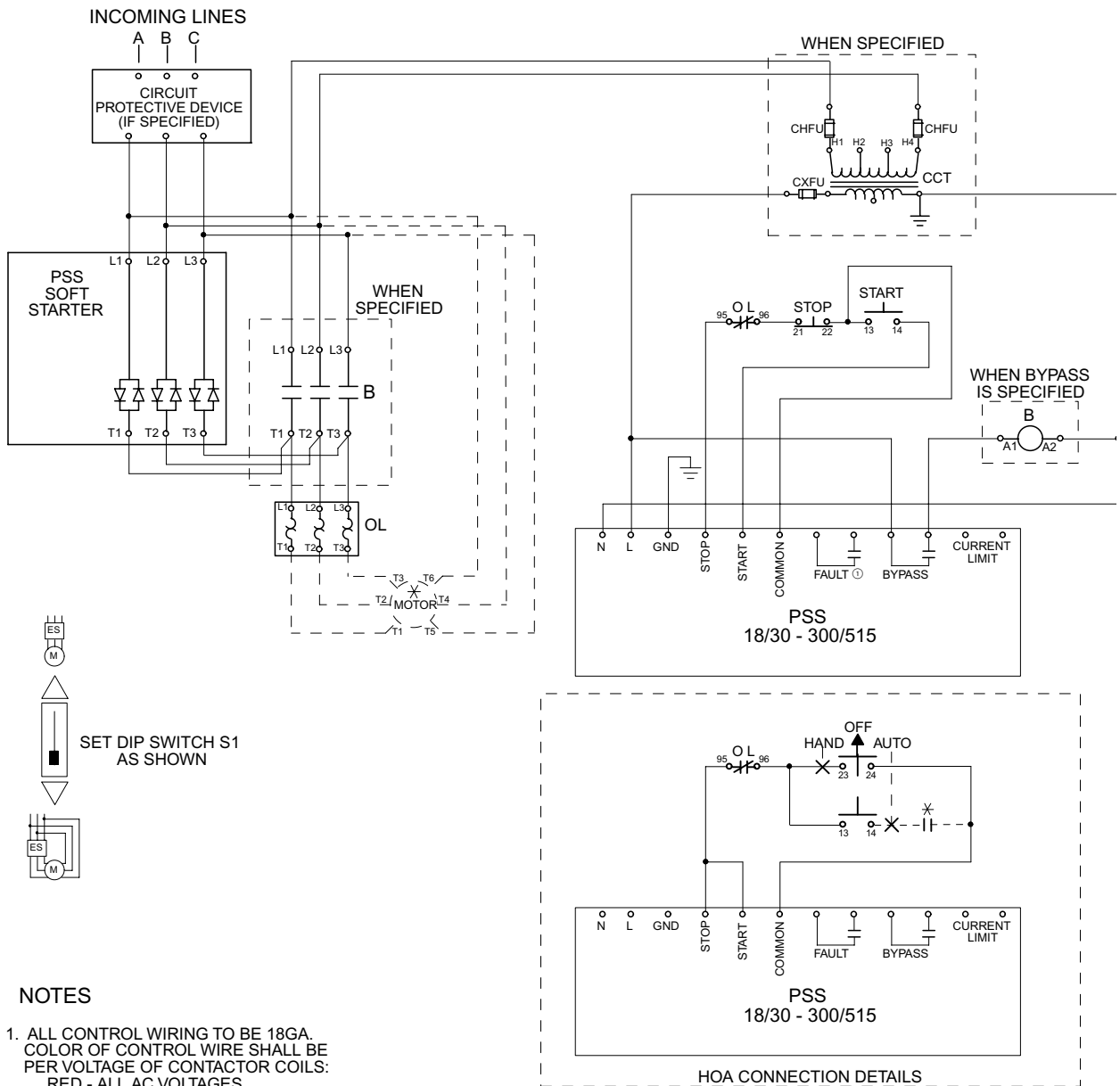

① Can also be ordered as a normally closed fault contact.

10. Circuit diagrams

Type PSS, Circuit diagrams

PSS18/30 – PSS300/515, Delta motor configuration, fault contactor

10.3 Circuit diagram – Delta motor configuration with fault contactor

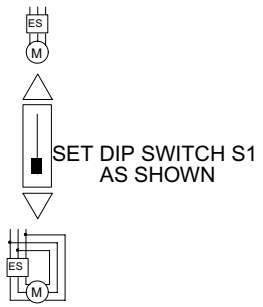
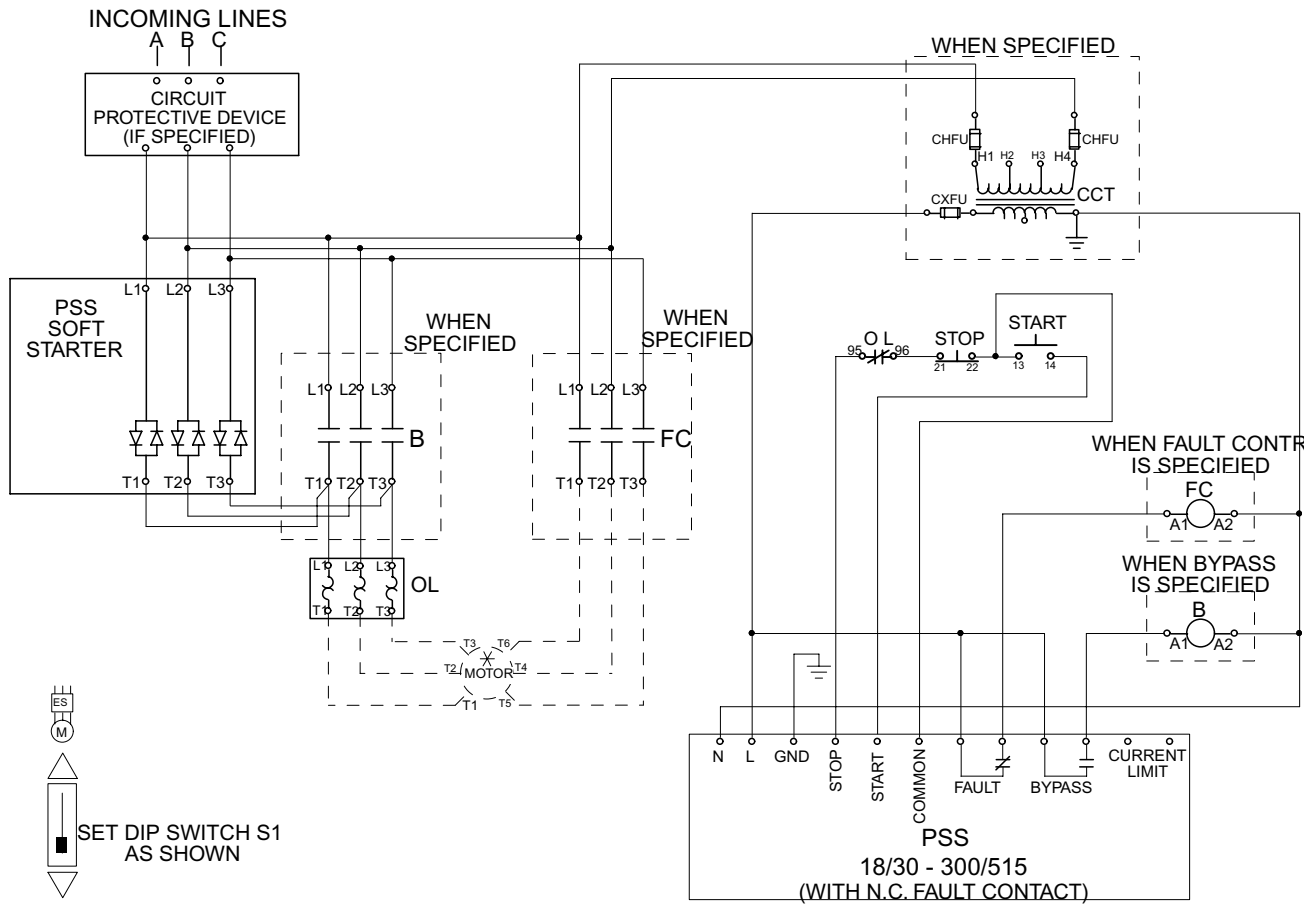

NOTES

1. ALL CONTROL WIRING TO BE 18GA. COLOR OF CONTROL WIRE SHALL BE PER VOLTAGE OF CONTACTOR COILS:
 RED - ALL AC VOLTAGES
 WHITE MAY BE USED ON THE GROUNDED SIDE OF THE AC CIRCUIT IF SPECIFIED.
 BLUE - ALL DC VOLTAGES
2. ALL DEVICES ARE SHOWN DE-ENERGIZED.
3. DO NOT USE SELECTOR SWITCHES WITH AUTO-RESET OVERLOAD RELAYS.

LEGEND	
CCT	CONTROL CIRCUIT TRANSFORMER
CHF1	CCT PRIMARY FUSE
CHF2	CCT PRIMARY FUSE
CHF3	CCT PRIMARY FUSE
CHF4	CCT PRIMARY FUSE
CXFU	CCT SECONDARY FUSE
B	BYPASS CONTACTOR
OL	OVERLOAD RELAY
° ₁₃	CONN POINT ON DEVICE WITH NUMBER
⊗	REMOTE DEVICE
∅	CONN POINT AT TERMINAL BLOCK

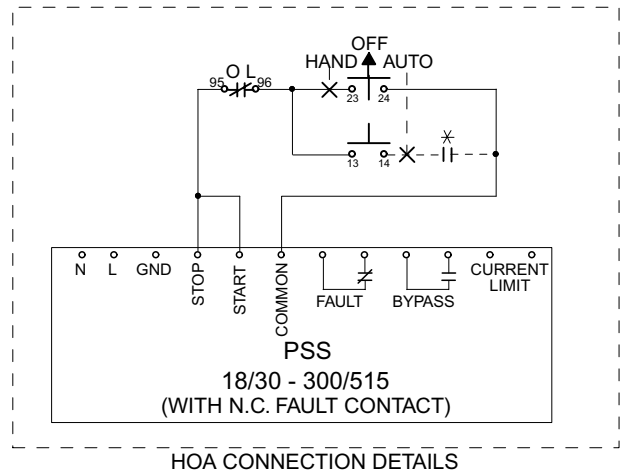

11. Approximate dimensions

11.1 Dimensions (mm)

PSS18/30-500...44/76-500

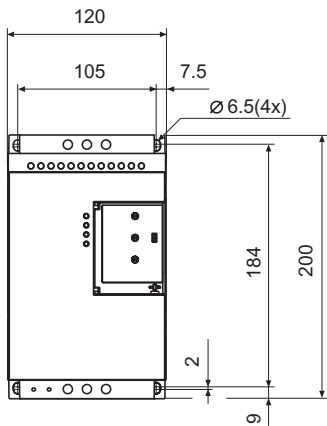
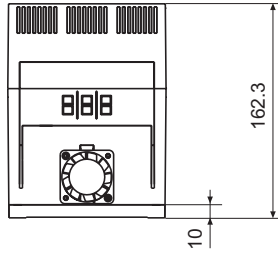

PSS50/85-500...72/124-500
PSS18/30-690...72/124-690

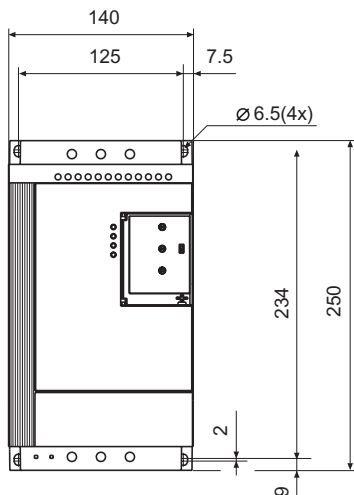
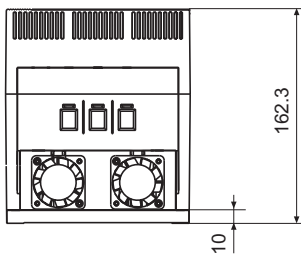

PSS85/147-500...142/245-500
PSS85/147-690...142/245-690

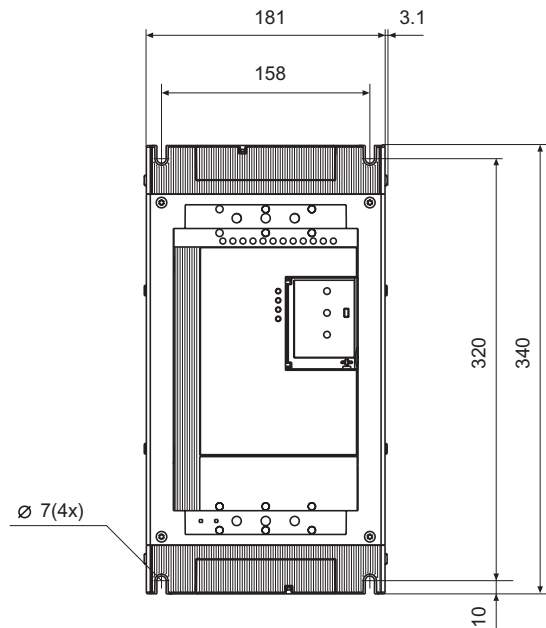
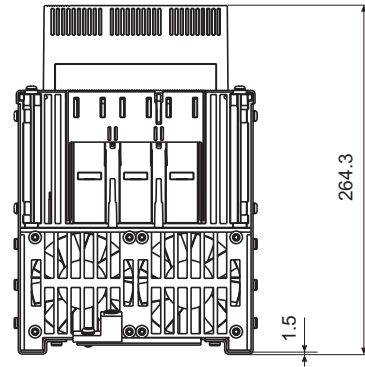

11. Approximate dimensions

PSS175/300...300/515

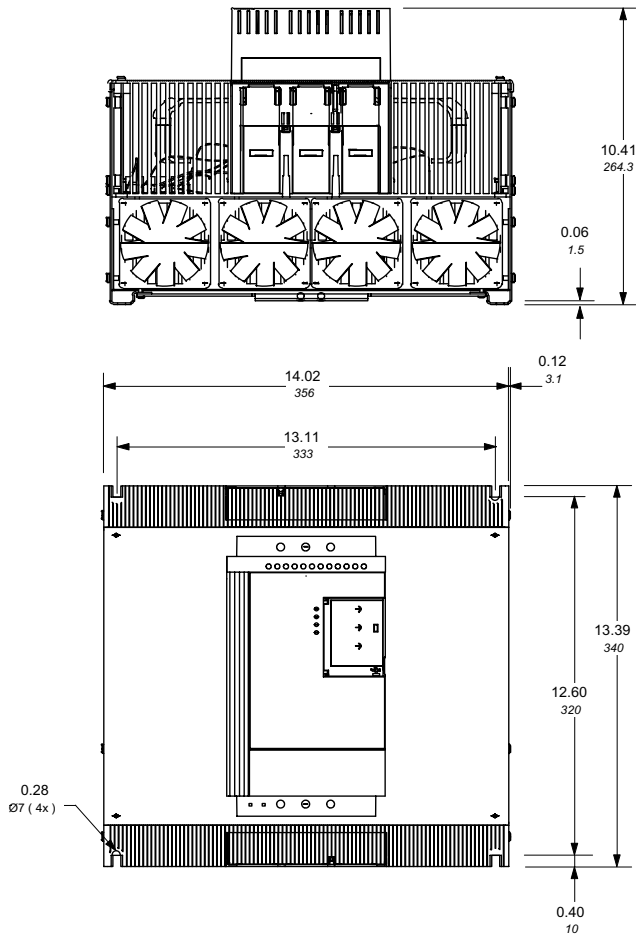

Low Voltage Products & Systems

ABB Inc.
1206 Hatton Road
Wichita Falls, TX 76302
Tel. 888-385-1221
940-397-7000
Fax 940-397-7085
Web www.abb-control.com